

ifm electronic



Operating instructions  
AS-i SmartLine module

**AS interface**

**UK**

**AC3202**

**AC3203**

**AC3204**

80228970/00 05/2015

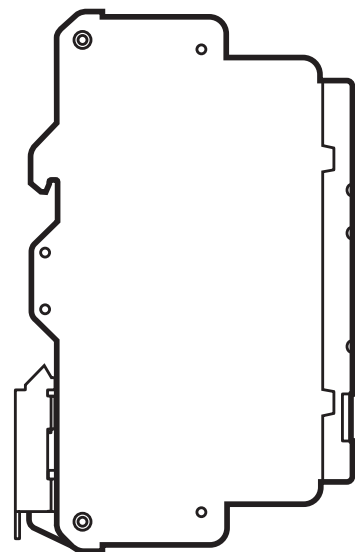

# Contents

1 Preliminary note.....	3
1.1 Symbols used.....	3
1.2 Warnings used.....	3
2 Safety instructions .....	4
2.1 General.....	4
2.2 Target group.....	4
2.3 Electrical connection.....	4
2.4 Operation.....	5
2.5 Installation location .....	5
2.6 Housing temperature .....	5
2.7 Tampering with the device .....	5
3 functions and features .....	5
4 Operating and display elements .....	6
4.1 Digital input modules AC3202 and AC3204 .....	6
4.2 Digital output module AC3203.....	7
5 Operation / LEDs .....	7
6 Installation.....	8
6.1 Installation of the device .....	8
6.2 Removal of the device .....	8
6.3 Mounting of the sensors .....	8
7 Electrical connection.....	9
7.1 Connection accessories .....	9
7.2 Terminal connection.....	9
7.2.1 Digital input modules AC3202 and AC3204 .....	9
7.2.2 Digital output module AC3203.....	10
8 Addressing.....	11
8.1 Addressing with the AC1154 addressing unit.....	11
9 Technical data.....	12
9.1 Scale drawing .....	14
10 Approvals / standards .....	14
11 Maintenance, repair, disposal .....	14

11.1 Maintenance .....	14
11.2 Cleaning of the housing surface .....	14
11.3 Repair .....	14
11.4 Disposal .....	15

# 1 Preliminary note



UK

This document is intended for specialists. These specialists are people who are qualified by their training and their experience to see risks and to avoid possible hazards that may be caused during operation, installation or maintenance of the device.

Read this document before use to familiarise yourself with operating conditions, installation and operation. Keep this document during the entire duration of use of the device.

<b>⚠ WARNING</b>	Adhere to the warning notes and safety instructions (→ 2 Safety instructions).
------------------	--

## 1.1 Symbols used

- ▶ Instruction
- Cross-reference
-  Important note  
Non-compliance may result in malfunction or interference
-  Information  
Supplementary note
-  General warning  
Non-compliance may result in personal injury

## 1.2 Warnings used

<b>⚠ WARNING</b>	Warning of serious personal injury. Death or serious irreversible injuries may result.
------------------	---

## **2 Safety instructions**

### **2.1 General**

Follow the operating instructions. Non-observance of the instructions, operation which is not in accordance with use as prescribed below, wrong installation or incorrect handling can affect the safety of operators and machinery.

The installation and connection must comply with the applicable national and international standards. Responsibility lies with the person installing the device.

The system installer is responsible for the safety of the system into which the device is integrated.

### **2.2 Target group**

The device must only be installed, connected and put into operation by a qualified electrician.

### **2.3 Electrical connection**

Disconnect the unit externally before handling it.

Make sure that the external voltage is generated and supplied according to the requirements for safety extra-low voltage (SELV) since this voltage is supplied without further measures near the operating elements and at the terminals for the supply of connected sensors.

The wiring of all signals in connection with the SELV circuit of the device must also comply with the SELV criteria (safety extra-low voltage, safe electrical isolation from other electric circuits).

If the externally supplied or internally generated SELV voltage is externally grounded, the responsibility lies with the user in accordance with the applicable national installation regulations. All statements in these operating instructions refer to the unit the SELV voltage of which is not grounded.

The consumption of current which exceeds the value given in the technical data is not allowed.

An external main switch must be installed for the unit which can switch off the unit and all related circuits. This main switch must be clearly assigned to the unit.

### **2.4 Operation**

Be careful when handling the unit once power is applied. This is only allowed by qualified personnel due to the protection rating IP 20.

## 2.5 Installation location

For the correct operation, the device must be mounted in a housing which can only be opened using a tool or in a locked control cabinet (both protection rating IP 54 or higher) as an enclosure.

## 2.6 Housing temperature

As described in the technical specifications below, the device can be operated in a wide ambient temperature range. Because of the additional internal heating the operating elements and the housing walls can have high perceptible temperatures when touched in hot environments.

UK

## 2.7 Tampering with the device

In case of malfunction of the unit or queries please contact the manufacturer. Any tampering with the device can seriously affect the safety of operators and machinery. This is not permitted and leads to the exclusion of any liability and warranty claims.

## 3 Functions and features

- A maximum of 4 sensors (2-wire or 3-wire sensors) can be connected to the digital input modules AC3202 and AC3204.
- A maximum of 4 actuators can be connected to the AS-i master on the digital output module AC3203.
- AC3202: sensor supply via AS-i max. 200 mA
- AC3204: sensor supply via AUX max. 1 A
- Maximum number of modules per master:
  - 31 (AC3203)
  - 62 (AC3202, AC3204)
- AS-interface version 3.0, downward compatible

## 4 Operating and display elements

### 4.1 Digital input modules AC3202 and AC3204

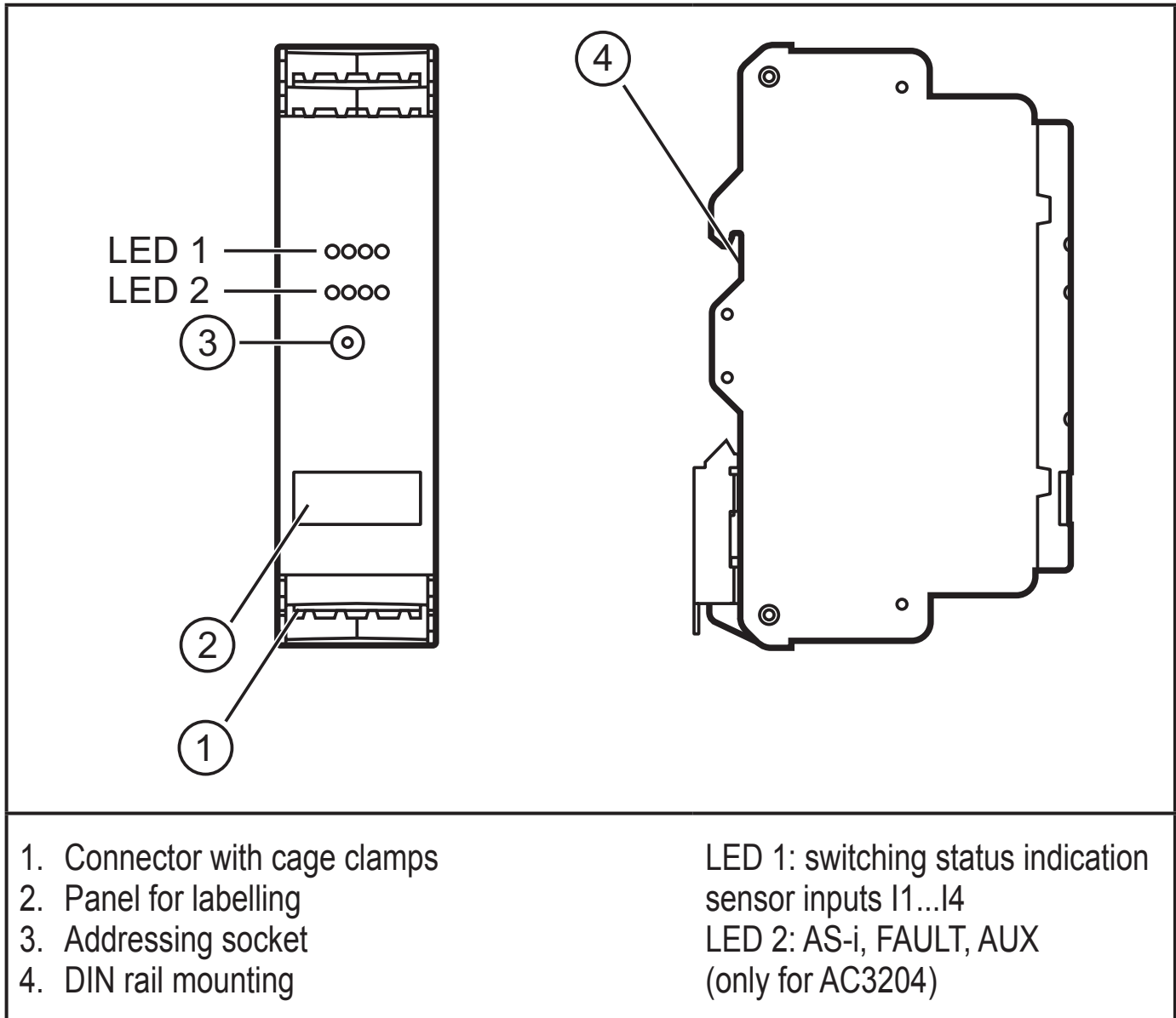

## 4.2 Digital output module AC3203

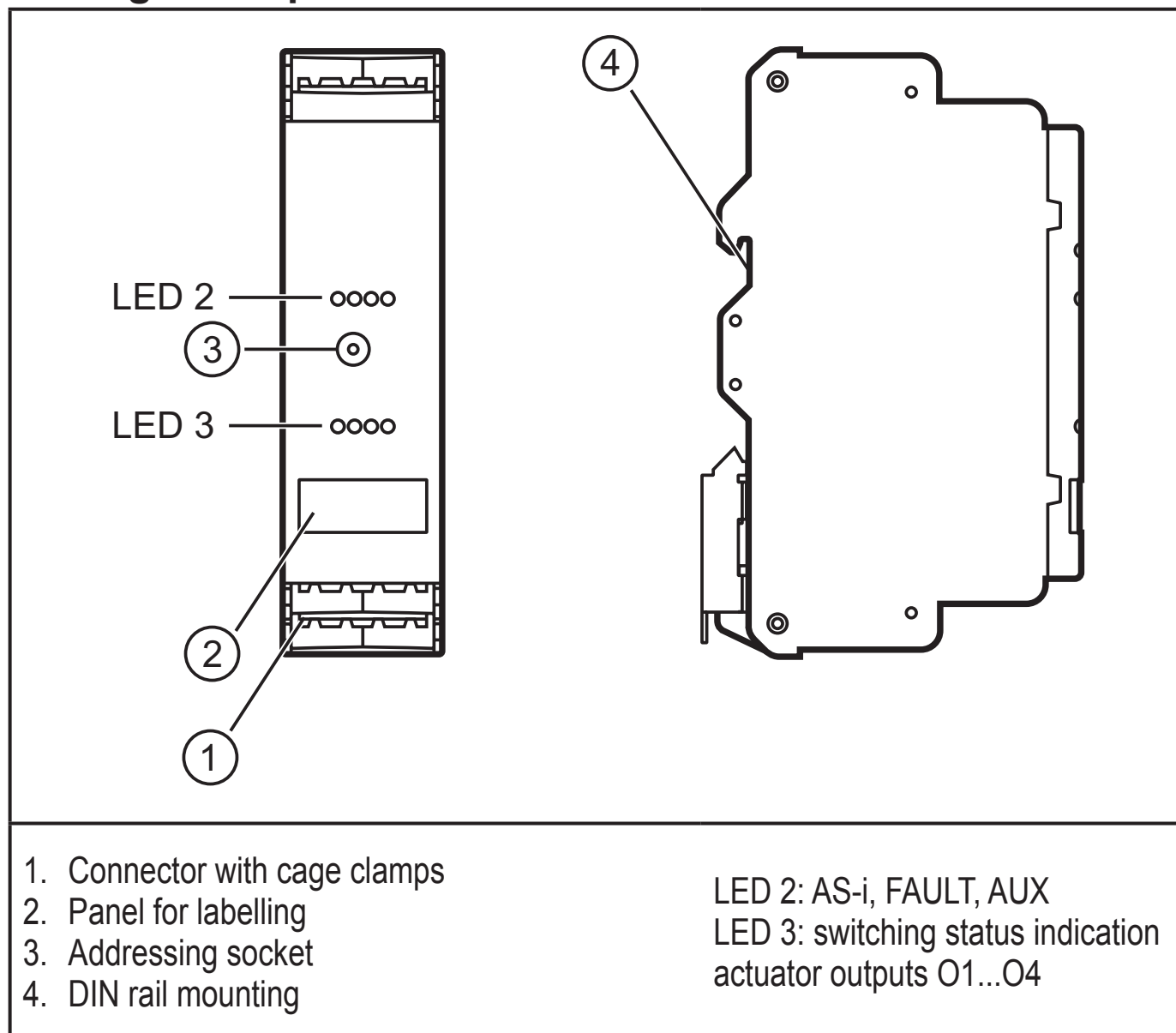

UK

## 5 Operation / LEDs

- LED 1 yellow lights: inputs (I1...I4) switched
- LED 2 AS-i green lights: AS-i voltage supply ok
- LED 2 FAULT red lights: AS-i communication error, slave does not participate in the "normal" exchange of data, e.g. slave address 0
- LED 2 FAULT red flashes: peripheral fault, e.g. sensor supply / output overloaded or shorted
- LED 2 AUX green lights: external voltage supply ok
- LED 3 yellow lights: output (O1...O4) switched

## 6 Installation

### 6.1 Installation of the device

- ▶ Install the device on a 35 mm DIN rail.

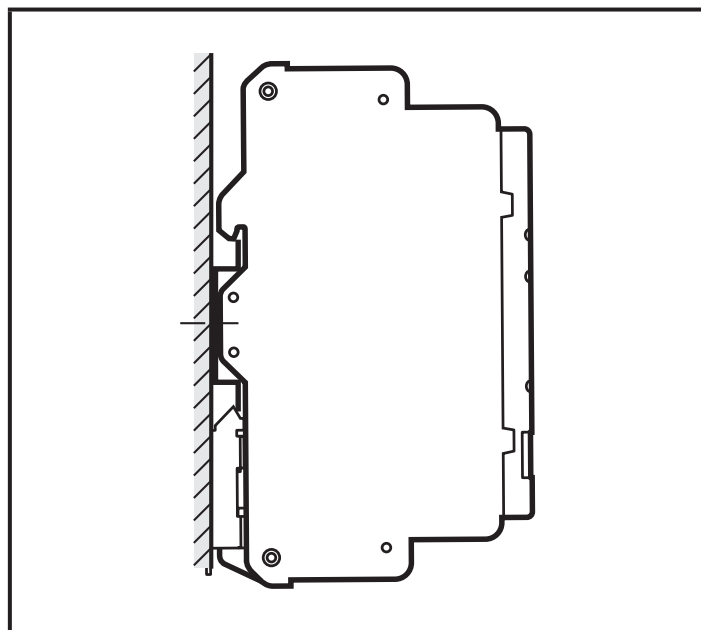
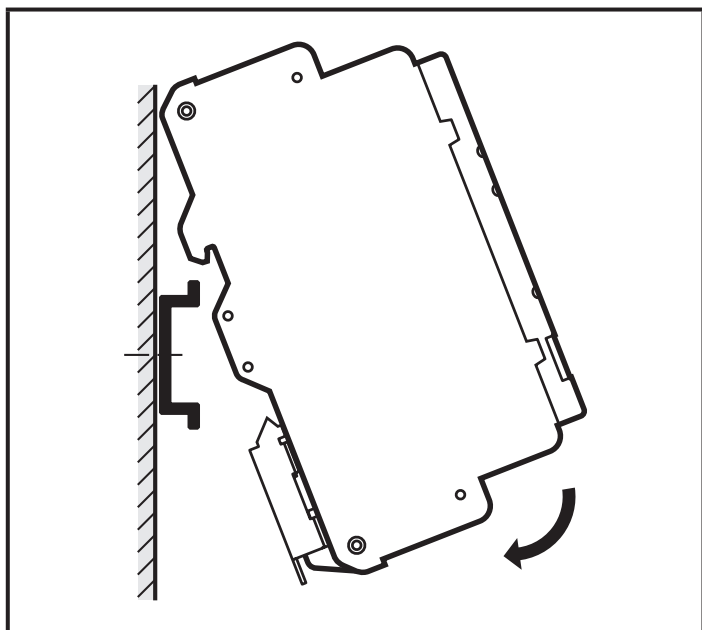

- ▶ Leave enough space between the unit and the top and bottom of the control cabinet to enable air circulation and to avoid excessive heating.
- ▶ Take into account the internal heating of all devices when mounting several devices side by side and observe the environmental conditions for every device.

### 6.2 Removal of the device

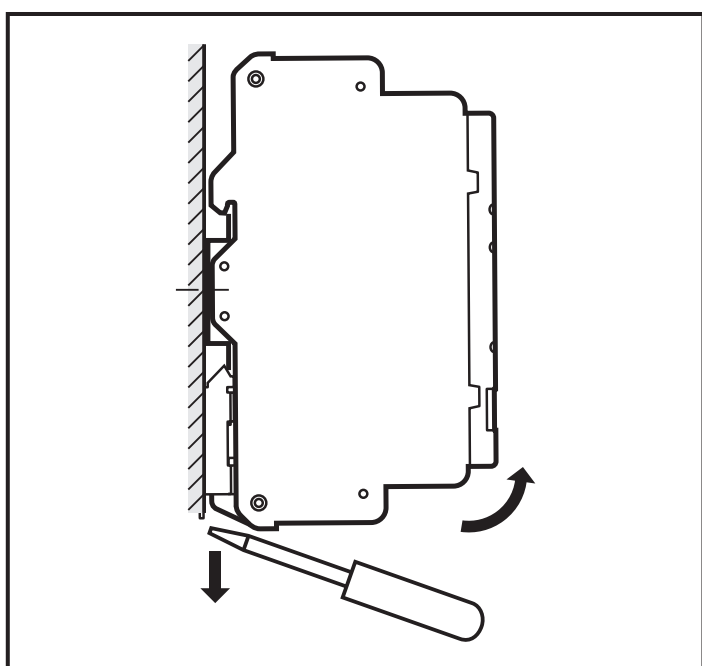



## 6.3 Mounting of the sensors

► Follow the manufacturer's installation instructions.

# 7 Electrical connection

## 7.1 Connection accessories

The unit is supplied including connectors.

You can find more information about the available accessories at:

[www.ifm.com](http://www.ifm.com) → Data sheet search → Enter the article number → Accessories

## 7.2 Terminal connection

### 7.2.1 Digital input modules AC3202 and AC3204

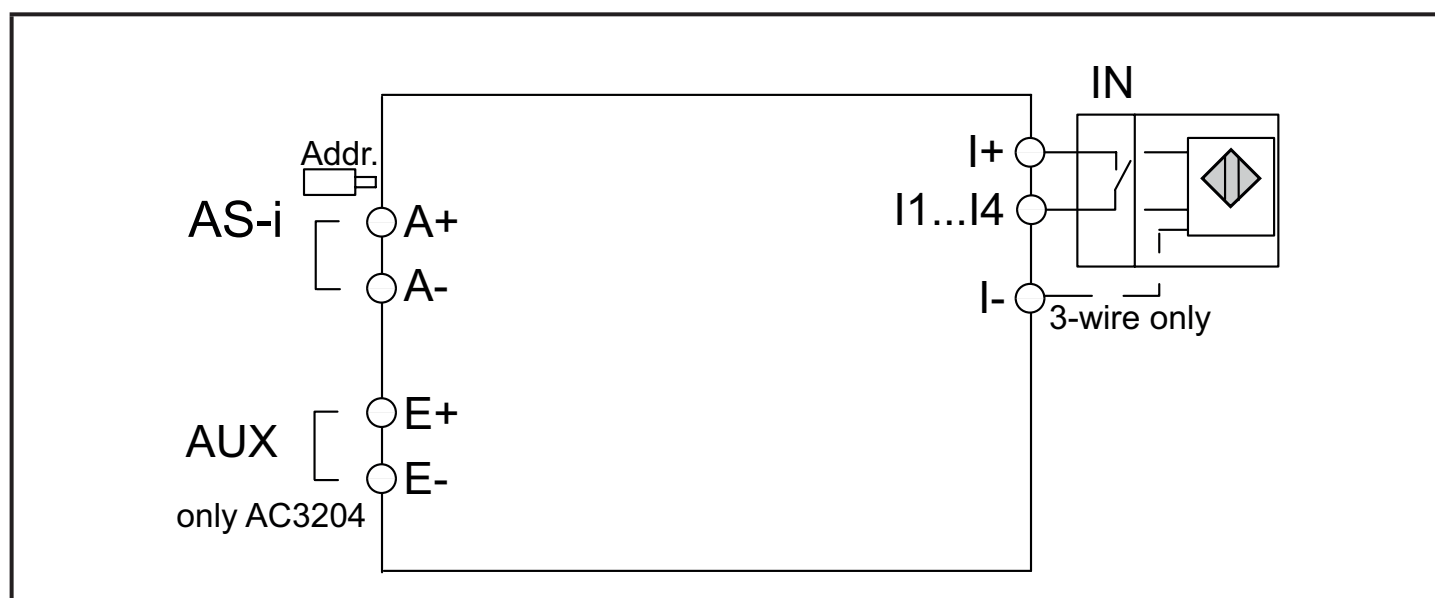

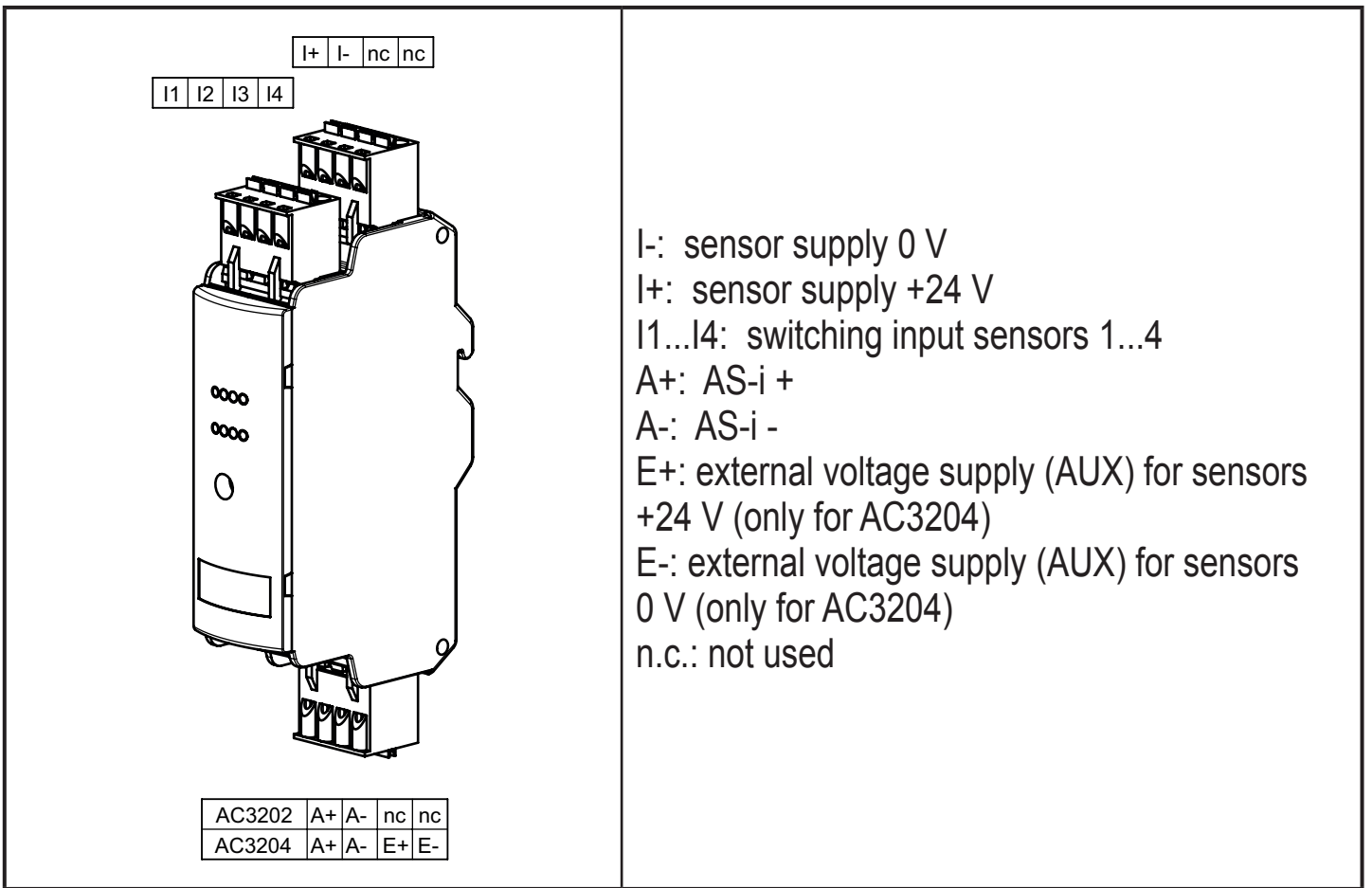

## 7.2.2 digital output module AC3203

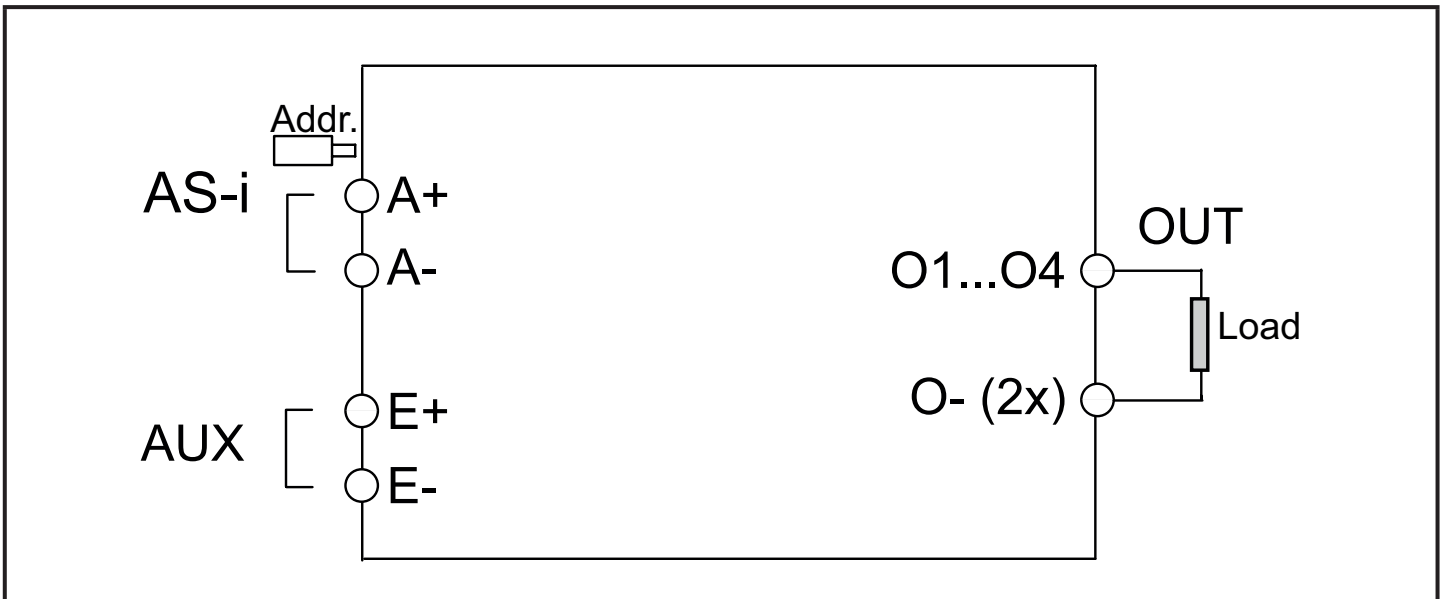

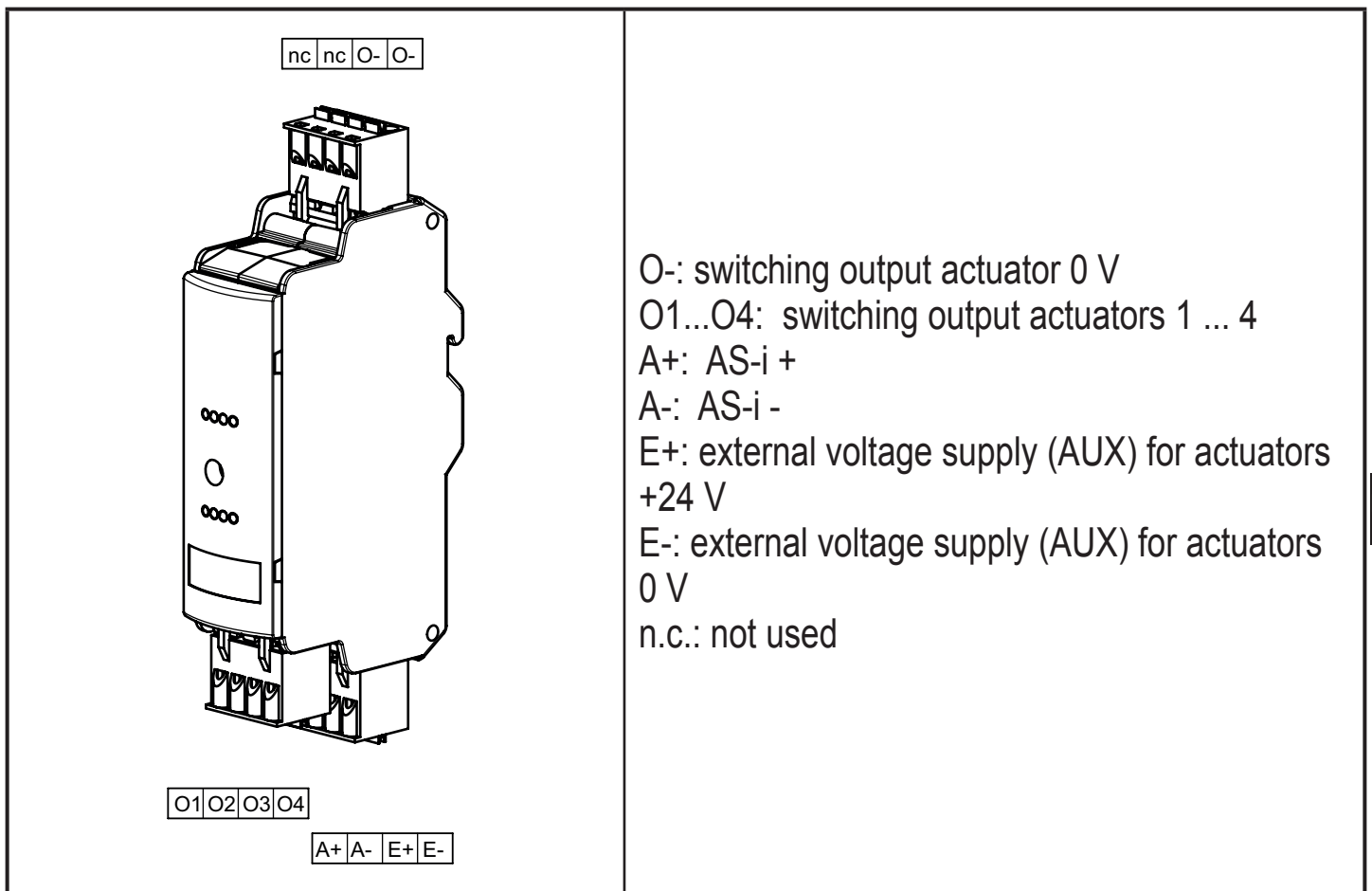

UK

**⚠ WARNING**  
 To ensure protection rating IP20 for the housing and the terminals, connect terminals to all the unused connector contacts.

**⚠ WARNING**  
 Connect a fuse to the AUX supply cable E+ upstream  
 → Technical data

**!** AC3202, AC3204  
 Do not connect the terminals I1...I4 and I+, I- to external potential.

**i** AC3203  
 The switch-on and switch-off capacity for triggering solenoids is rated up to 20 W (according to IEC 60947-5-2, utilisation category DC-13).

## 8 Addressing

The address is set to 0 at the factory.

## 8.1 Addressing with the AC1154 addressing unit

When mounted and wired, the module can be addressed with the addressing cable (E70213) via the integrated addressing interface.

If a slave with the extended addressing mode is used in combination with a master of the first generation (version 2.0), the parameter P3 must be 1 and the output bit D3 must be 0\*. The output bit D3 and the parameter bit P3 must not be used.

If a slave with the extended addressing mode is used in combination with a master of the first generation (version 2.0), an address between 1A and 31A must be assigned to this slave.

\* Default setting

## 9 Technical data

SmartLine modules		AC3202 / AC3204
Electrical design		4 digital inputs
Operating voltage	[V]	AC3202 / AC3204: 18...31.6 DC (AS-i), AC3204: 20...30 DC (AUX)
Total current consumption from AS-i	[mA]	AC3202: < 250 AC3204: < 30
Fuse for AUX	[A]	AC3204: 2 (T)
Inputs		PNP (type 2 to IEC 61131-2)
Sensor supply		AC3202 AS-i AC3204: external to SELV
Voltage range inputs	[V]	16...30 DC
Max. total current load for all inputs	[mA]	AC3202: 200 AC3204: 1000
Protection housing / terminals		IP 20 / IP 20
Ambient temperature	[°C]	-25...65
Max. perm. relative air humidity	[%]	90 (not condensing)
Maximum operating altitude	[m]	2000 above sea level
AS-i profile		S-0.A.E
AS-i version		2.11 + 3.0 (extended addressing mode)
Connection		
Maximum cable length on the inputs	[m]	30
Device		4-pole terminal blocks with 5.0 mm pitch
Connectors (all connectors are supplied with the device)		1x4-pole twin connector with cage clamp connection from Phoenix Contact, type TVFKC 1,5/4-ST BK 0.2...1.5 mm <sup>2</sup> (AWG 24...16)  2x4-pole connector with cage clamp connection from Phoenix Contact, type 1,5/4-ST BK 0.2..2.5 mm <sup>2</sup> (AWG 24...14)

UK

SmartLine module		AC3203
Electrical design		4 digital outputs
Operating voltage	[V]	18...31.6 DC (AS-i), 20...30 DC (AUX)
Total current consumption from AS-i	[mA]	< 30
Current rating per module	[A]	4, > 50°C: 2
Fuse for AUX	[A]	6 (T)
Outputs		transistor PNP
Switching voltage per output	[V]	24 DC (20...30 DC), external to SELV
Current rating per output	[A]	1 utilisation category DC-13; utilisation category DC-12: 700mA. the switch-on and switch-off capacity for triggering solenoids is rated up to 20 W (according to IEC 60947-5-1)
Protection housing / terminals		IP 20 / IP 20
Ambient temperature	[°C]	-25...65
Max. perm. relative air humidity	[%]	90 (not condensing)
Maximum operating altitude	[m]	2000 above sea level
AS-i profile		S-8.0.E
AS-i version		2.11 + 3.0
Connection		
Maximum cable length on the outputs	[m]	30
Device		4-pole terminal blocks with 5.0 mm pitch
Connectors (all connectors are supplied with the device)		1x4-pole twin connector with cage clamp connection from Phoenix Contact, type TVFKC 1,5/4-ST BK 0.2 mm <sup>2</sup> ...1.5 mm <sup>2</sup> (AWG 24...16)  2x4-pole connector with cage clamp connection from Phoenix Contact, type 1,5/4-ST BK 0.2..2.5 mm <sup>2</sup> (AWG 24...14)

Data sheets are available at:  
[www.ifm.com](http://www.ifm.com) → Data sheet search → Article number

## 9.1 Scale drawing

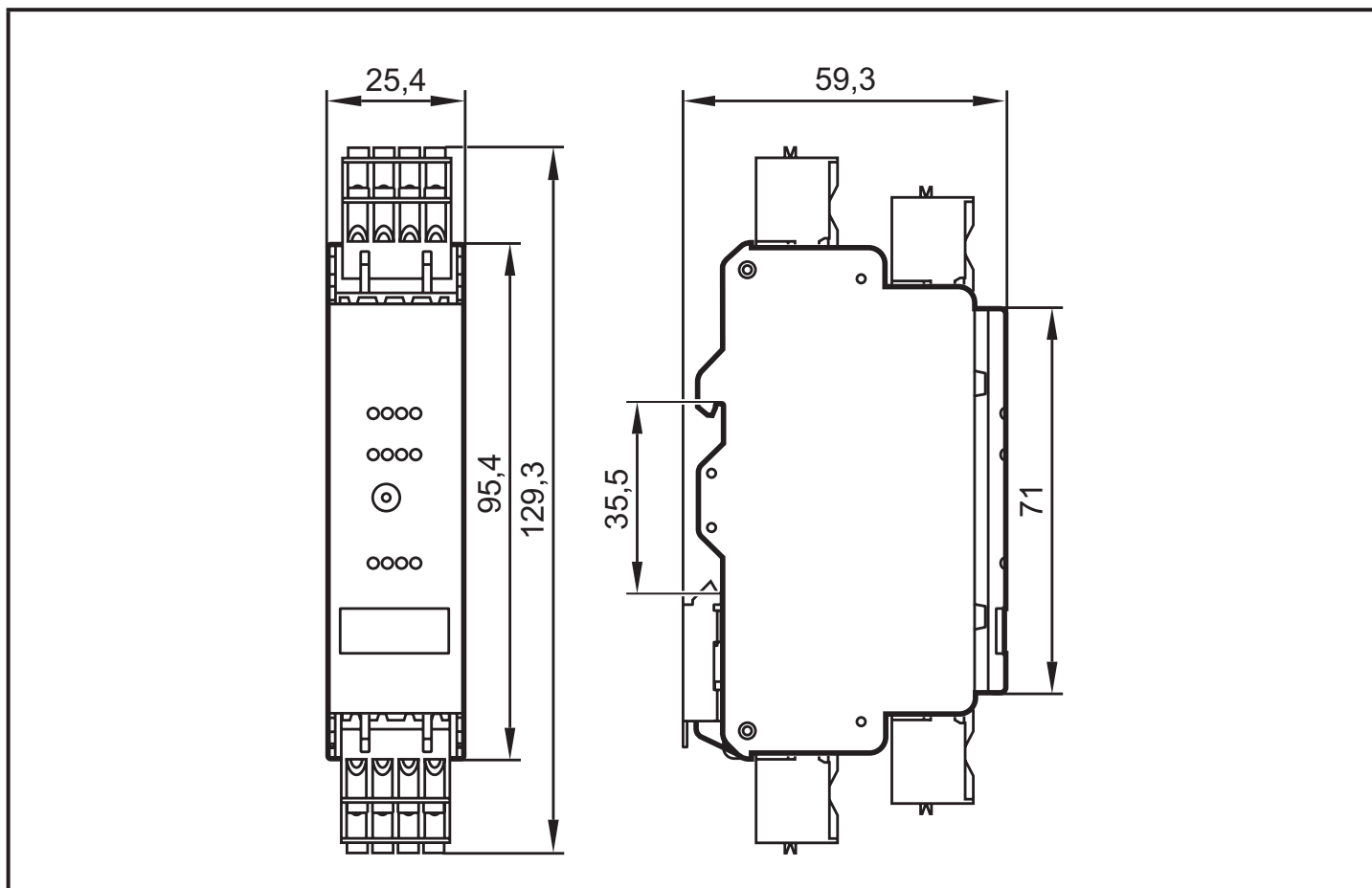

UK

## 10 Approvals/standards

EC declarations of conformity, approvals etc. can be downloaded at: [www.ifm.com](http://www.ifm.com)  
→ Data sheet search → Article number → More information

## 11 Maintenance, repair, disposal

### 11.1 Maintenance

The unit is maintenance-free.

### 11.2 Cleaning of the housing surface

- ▶ Disconnect the device.
- ▶ Clean the device from dirt using a soft, chemically untreated and dry cloth.



Micro-fibre cloths without chemical additives are recommended.

### **11.3 Repair**

- ▶ The device must only be repaired by the manufacturer.  
Observe the safety instructions (→ 2.7 Tampering with the device).

### **11.4 Disposal**

- ▶ Dispose of the device in accordance with the national environmental regulations.



