



PSEN cs3.1n

PILZ
THE SPIRIT OF SAFETY

- ▶ PSEN sensor technology

This document is the original document.

All rights to this documentation are reserved by Pilz GmbH & Co. KG. Copies may be made for the user's internal purposes. Suggestions and comments for improving this documentation will be gratefully received.

Source code from third-party manufacturers or open source software has been used for some components. The relevant licence information is available on the Internet on the Pilz homepage.

Pilz®, PIT®, PMI®, PNOZ®, Primo®, PSEN®, PSS®, PVIS®, SafetyBUS p®, SafetyEYE®, SafetyNET p®, the spirit of safety® are registered and protected trademarks of Pilz GmbH & Co. KG in some countries.



SD means Secure Digital

Introduction	5
Validity of documentation	5
Using the documentation	5
Definition of symbols	5
Safety	6
Intended use	6
Safety regulations	7
Safety assessment	7
Use of qualified personnel	7
Warranty and liability	7
Disposal	7
For your safety	8
Unit features	8
Function description	9
Basic function	9
Block diagram	9
Operating distances	10
Lateral and vertical offset	10
Wiring	12
Pin assignment, connector and cable	12
Connection to evaluation devices	13
Teaching in the actuator	15
Installation	15
General	15
Safety switch	15
Actuator cs1.1 or cs3.1	16
Actuator cs3.1 low profile	17
Align safety switch and actuator	21
Adjustment	21
Operation	22
Dimensions in mm	23
Safety switch PSEN cs3.1n	23
Actuator	24

Technical details safety switch	26
Technical details actuator	29
Classification according to ZVEI, CB24I	31
Safety characteristic data	32
Supplementary data	33
Radio approval.....	33
Order reference	33
Safety switch.....	33
Actuator	33
Complete systems	33
Accessories	34
EC declaration of conformity	35

Introduction

Validity of documentation

This documentation is valid for the product PSEN cs3.1n. It is valid until new documentation is published.

This operating manual explains the function and operation, describes the installation and provides guidelines on how to connect the product.

Using the documentation

This document is intended for instruction. Only install and commission the product if you have read and understood this document. The document should be retained for future reference.

Definition of symbols

Information that is particularly important is identified as follows:



DANGER!

This warning must be heeded! It warns of a hazardous situation that poses an immediate threat of serious injury and death and indicates preventive measures that can be taken.



WARNING!

This warning must be heeded! It warns of a hazardous situation that could lead to serious injury and death and indicates preventive measures that can be taken.



CAUTION!

This refers to a hazard that can lead to a less serious or minor injury plus material damage, and also provides information on preventive measures that can be taken.



NOTICE

This describes a situation in which the product or devices could be damaged and also provides information on preventive measures that can be taken. It also highlights areas within the text that are of particular importance.

**INFORMATION**

This gives advice on applications and provides information on special features.

Safety**Intended use**

The safety functions of the safety switch are:

- ▶ Safe shutdown of safety outputs when the actuator is removed beyond the assured release distance s_{ar} or when the actuator is not detected
- ▶ Remain shut down safely after the actuator has been removed

The safety switch meets the requirements in accordance with:

- ▶ EN 60947-5-3: PDDB with one of the approved actuators
- ▶ EN 62061: SIL CL 3
- ▶ EN ISO 13849-1: PL e (Cat. 4)
- ▶ EN ISO 14119: Coding level Low, type 4

The safety switch may only be used with one of the approved actuators.

The safety level PL e (Cat. 4)/SIL CL 3 is only achieved if

- ▶ the safety outputs use 2-channel processing.

The following is deemed improper use in particular

- ▶ Any component, technical or electrical modification to the product,
- ▶ Use of the product outside the areas described in this manual,
- ▶ Use of the product outside the technical details (see [Technical details](#)  26]).

**NOTICE****EMC-compliant electrical installation**

The product is designed for use in an industrial environment. The product may cause interference if installed in other environments. If installed in other environments, measures should be taken to comply with the applicable standards and directives for the respective installation site with regard to interference.

Approved actuators:

- ▶ PSEN cs3.1
- ▶ PSEN cs1.1
- ▶ PSEN cs3.1 low profile glue
- ▶ PSEN cs3.1 low profile screw

Safety regulations

Safety assessment

Before using a device it is necessary to perform a safety assessment in accordance with the Machinery Directive.

Functional safety is guaranteed for the product as a single component. However, this does not guarantee the functional safety of the overall plant/machine. In order to achieve the required safety level for the overall plant/machine, define the safety requirements for the plant/machine and then define how these must be implemented from a technical and organisational standpoint.

Use of qualified personnel

The products may only be assembled, installed, programmed, commissioned, operated, maintained and decommissioned by competent persons.

A competent person is a qualified and knowledgeable person who, because of their training, experience and current professional activity, has the specialist knowledge required. To be able to inspect, assess and operate devices, systems and machines, the person has to be informed of the state of the art and the applicable national, European and international laws, directives and standards.

It is the company's responsibility only to employ personnel who

- ▶ Are familiar with the basic regulations concerning health and safety / accident prevention,
- ▶ Have read and understood the information provided in the section entitled Safety
- ▶ Have a good knowledge of the generic and specialist standards applicable to the specific application.

Warranty and liability

All claims to warranty and liability will be rendered invalid if

- ▶ The product was used contrary to the purpose for which it is intended,
- ▶ Damage can be attributed to not having followed the guidelines in the manual,
- ▶ Operating personnel are not suitably qualified,
- ▶ Any type of modification has been made (e.g. exchanging components on the PCB boards, soldering work etc.).

Disposal

- ▶ In safety-related applications, please comply with the mission time T_M in the safety-related characteristic data.
- ▶ When decommissioning, please comply with local regulations regarding the disposal of electronic devices (e.g. Electrical and Electronic Equipment Act).

For your safety**WARNING!****Loss of safety function due to manipulation of the interlocking device**

Manipulation of the interlocking device may lead to serious injury and death.

- You should prevent any possibility of the interlocking device being manipulated through the use of a spare actuator.
- Keep the substitute actuator in a safe place and protect it from unauthorised access.
- If spare actuators are used, these must be installed as described in [Installation](#) [ 15].
- If the original actuators are replaced with substitute actuators, the original actuators must be destroyed before disposal.

- ▶ Do not remove the connector's protective cap until you are just about to connect the unit. This will prevent potential contamination.

Unit features

- ▶ Transponder technology for presence detection
- ▶ Pilz coding type: Coded
- ▶ Dual-channel operation
- ▶ 2 safety outputs
- ▶ LED display for:
 - State of the actuator
 - Supply voltage/fault
- ▶ 1 direction of actuation
- ▶ 5-pin M12 male connector

Function description

Basic function

The safety outputs may have a high or low signal, depending on the position of the actuator.

In a safe condition the safety outputs are in the OFF state.

State of the outputs:

Actuator in the response range	Safety output 12	Safety output 22
Yes	High	High
No	Low	Low

Block diagram

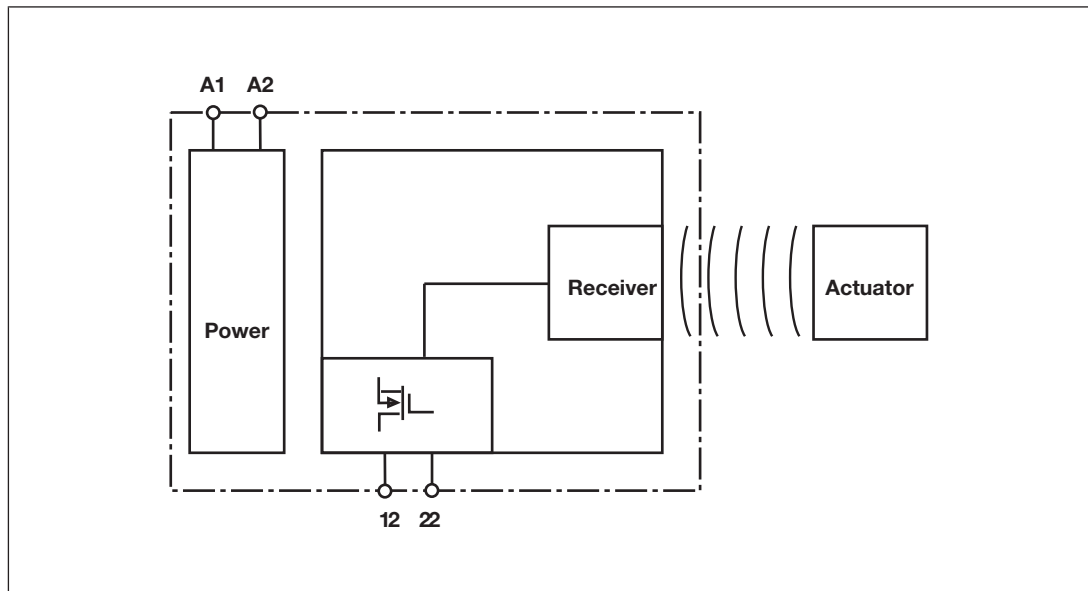

Operating distances

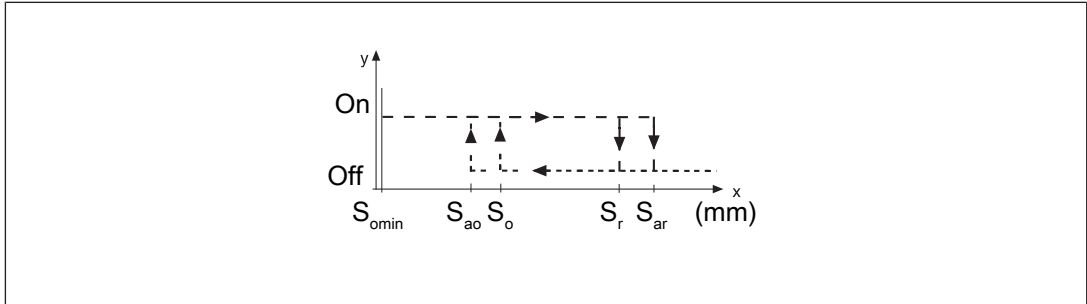

Legend

- S_{ao} Assured operating distance
- S_{omin} Min. operating distance
- S_{ar} Assured release distance

The offset-independent values for the switching distances are included in the [Technical details](#) [26].

Lateral and vertical offset

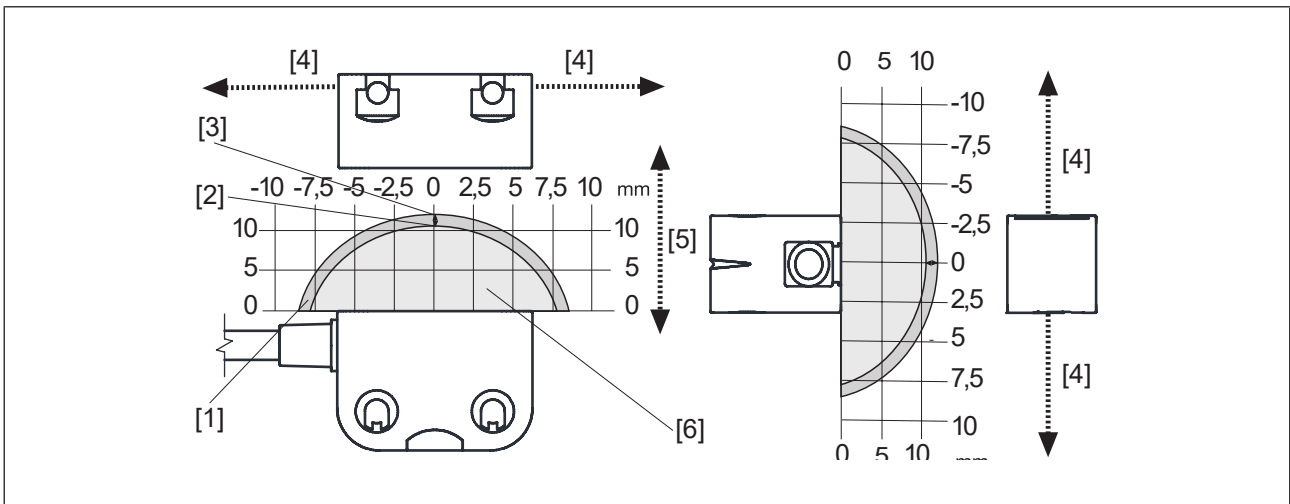

Fig.: Safety switches PSEN cs3.1n with actuator PSEN cs3.1

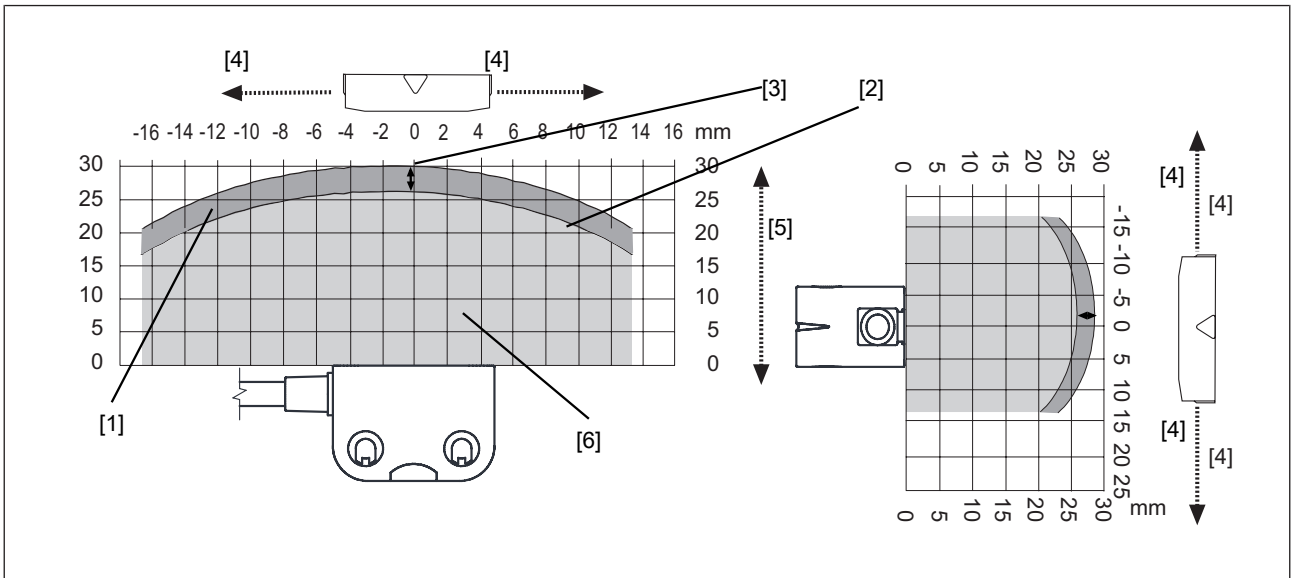

Fig.: Safety switches PSEN cs3.1n with actuator PSEN cs1.1

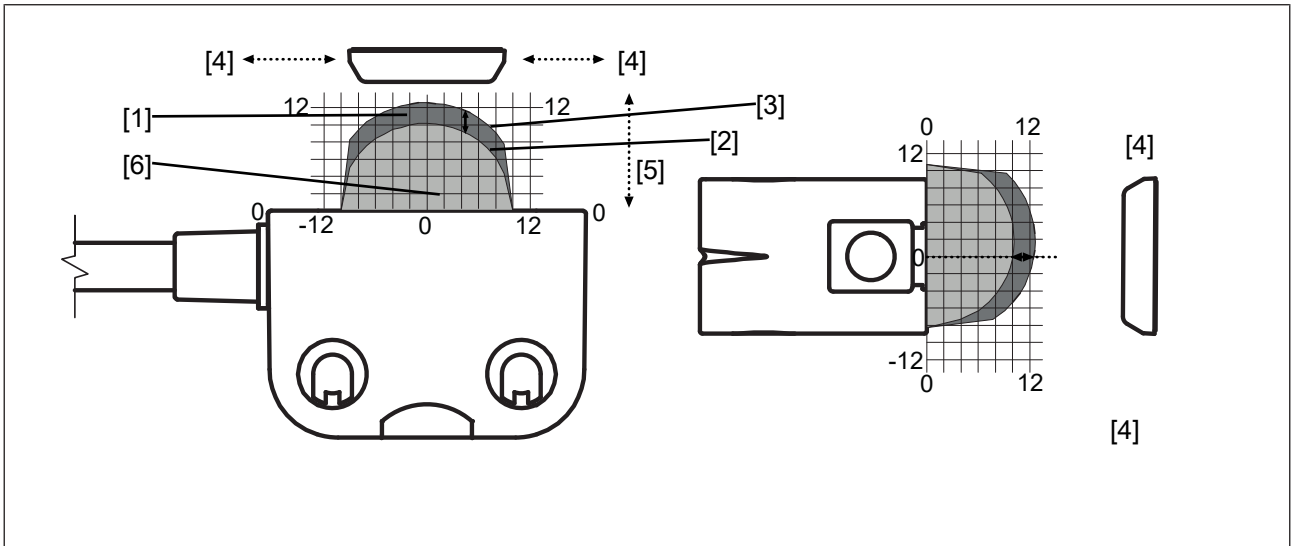

Fig.: Safety switches PSEN cs3.1n with actuator PSEN cs3.1 low profile glue or PSEN cs3.1 low profile screw

Legend

- [1] Hysteresis
- [2] Typical operating distance S_o
- [3] Typical release distance S_r
- [4] Offset in mm
- [5] Operating distance in mm
- [6] Response range

Wiring

Please note:

- ▶ Information given in the "Technical details" must be followed.
- ▶ Switch off the supply voltage before disconnecting the plug-in connection.
- ▶ Make sure that when connecting or separating the connector the pollution degree 1 or 2 is maintained.
- ▶ The power supply must meet the regulations for extra low voltages with protective electrical separation (SELV, PELV).
- ▶ The outputs of the safety switch must have a protective separation to voltages over 60 V AC.
- ▶ The supply voltage to the safety switch must be protected with a 2 A to 4 A quick-acting fuse.
- ▶ Ensure the wiring and EMC requirements of EN 60204-1 are met.

Pin assignment, connector and cable

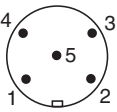
	5-pin M12 male connector
--	--------------------------

PIN	Pin designation	Function	Wire colour
1	A1	+24 UB	Brown
2	12	Output, channel1	White
3	A2	0 V UB	Blue
4	22	Output, channel2	Black
5	-	Do not connect	Grey

The wire colour also applies for the cable available from Pilz as an accessory.

Connection to evaluation devices

Make sure that the selected evaluation device has the following property:

- ▶ OSSD signals are evaluated through 2 channels with plausibility monitoring

Please note:

- ▶ Information given in the [Technical details \[26\]](#) must be followed.

Connection diagram, single connection

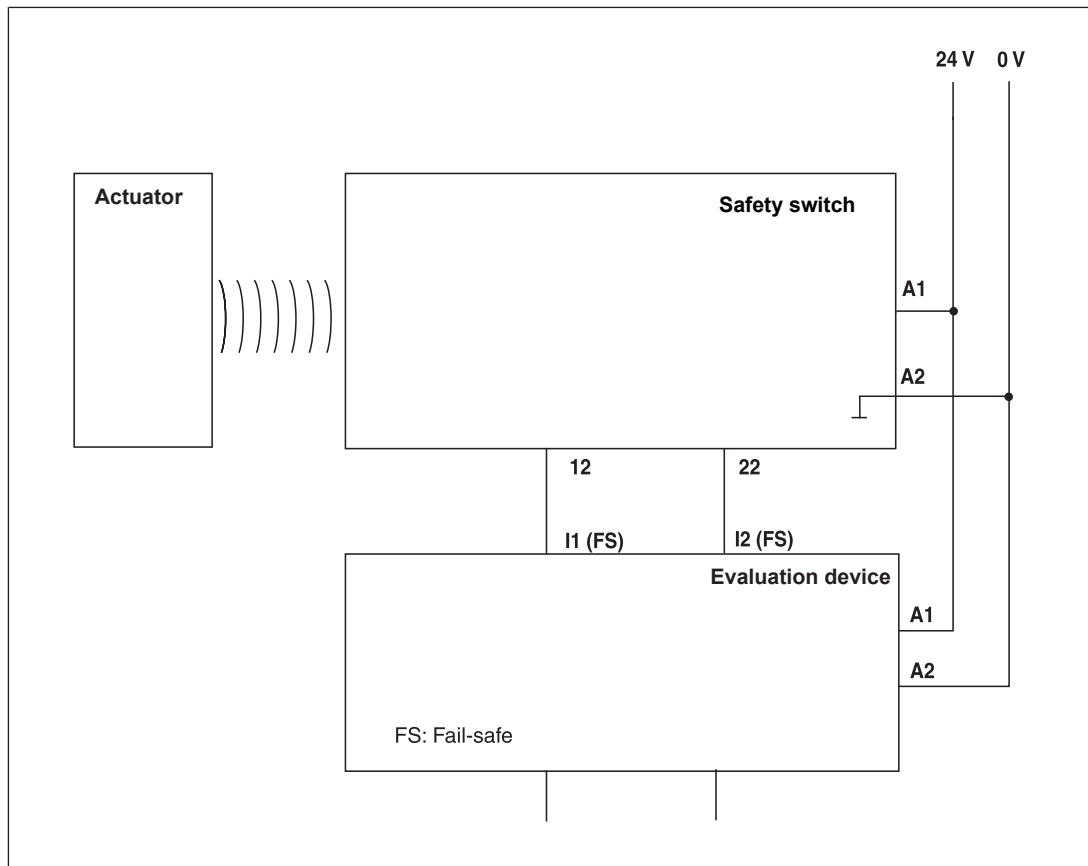

Suitable Pilz evaluation devices are, for example:

- ▶ PNOZelog for safety gate monitoring
- ▶ PNOZpower for safety gate monitoring
- ▶ PNOZsigma for safety gate monitoring
- ▶ PNOZ X for safety gate monitoring
- ▶ PNOZmulti for safety gate monitoring
Configure the switch in the PNOZmulti Configurator with switch type 3.
- ▶ PSS for safety gate monitoring with standard function block SB064, SB066 or FS_Safety Gate
- ▶ PSSuniversal PLC for safety gate monitoring with function block FS_SafetyGate

The correct connection to the respective evaluation device is described in the operating manual for the evaluation device. Make sure that the connection is made in accordance with the specifications in the operating manual for the selected evaluation device.

The connections to two evaluation devices are shown on the following pages, by way of example:

- ▶ PNOZ s3 and
- ▶ PNOZmulti

PNOZ s3

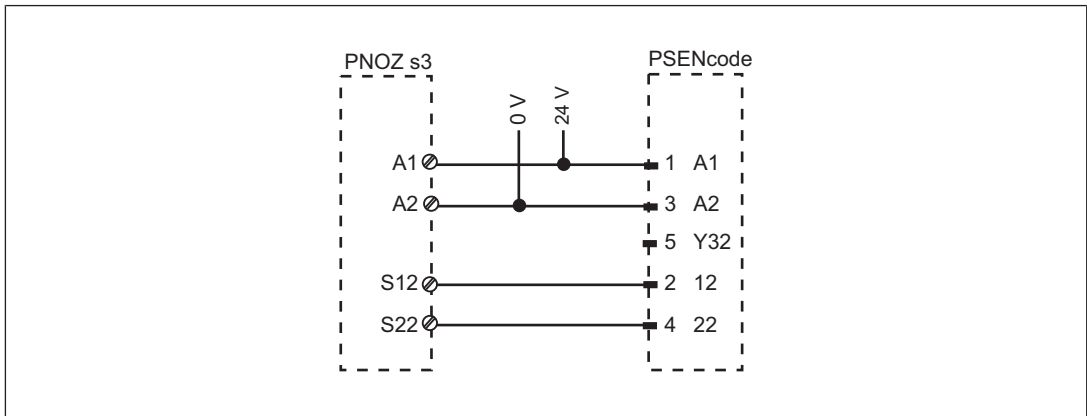

PNOZmulti

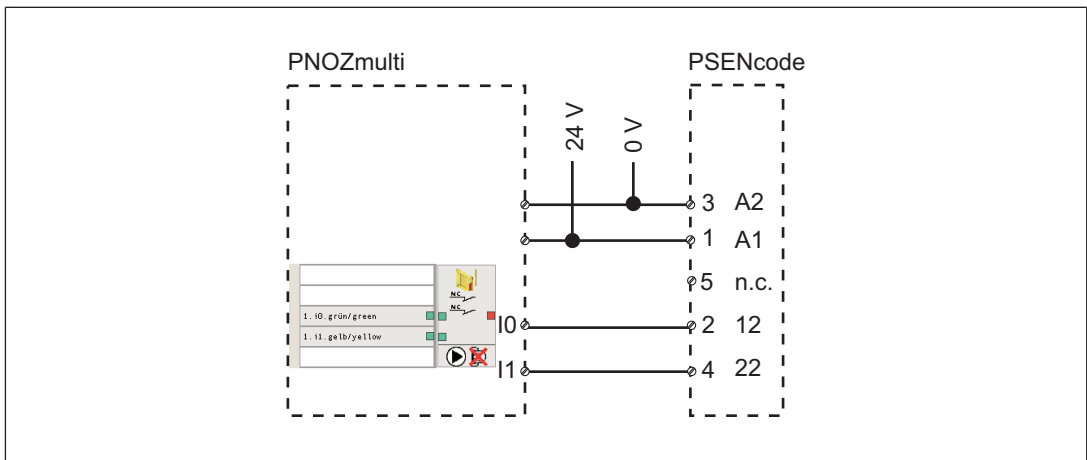

Teaching in the actuator

Any approved Pilz actuator (see Intended use) is detected as soon as it is brought into the response range.

Installation

General



CAUTION!

Potential loss of safety function due to changed device properties

The unit's properties may be affected if installed in an environment containing electrically or magnetically conductive material.

- Please check the operating distances and the assured release distance.

- ▶ The safety switch and actuator should be installed opposite each other in parallel.
- ▶ Torque setting: Please note the information provided under [Technical details \[26\]](#).
- ▶ The distance between two safety switches must be maintained (see [Technical details \[26\]](#)).
- ▶ Make sure that the safety switch and actuator cannot be used as an end stop.
- ▶ Please note the installation measures in accordance with EN ISO 14119 for a safety switch design 4 and with level of coding Low.
- ▶ Please note the permitted bending radii for the cable (see [Technical details \[26\]](#)), to avoid excessive force on the individual strands.
- ▶ Make sure that the bend protection is not damaged. Such damage can cause the whole product to fail.
- ▶ For simpler installation, the mounting brackets (see [Order reference for Accessories \[34\]](#)) can be used.

Safety switch

- ▶ Safety switches should only be secured using M4 screws with a flat head (e.g. M4 cheese-head or pan head screws).

Procedure:

1. Provide the mounting surface with two drill holes for fastening the safety switch (see [Dimensions in mm \[23\]](#)).
2. Use two screws to fix the safety switch in place. Do not fully tighten the 2nd screw on the safety switch.

Actuator cs1.1 or cs3.1

Procedure actuator PSEN cs3.1:

1. Only use M4 screws with a flat head (e.g. M4 cheese-head or pan head screws).
Provide the mounting surface with two drill holes for the screw connection of the actuator (see [Dimensions in mm](#) [ 23]).
2. Attach the screws for the actuator, leaving a distance of 3 ... 6 mm between the screw head and plate.
3. Slide the actuator on to the screws. The arrows on the labelled surfaces of the safety switch and actuator must face each other. Align the actuator and tighten the screws.
4. The actuator should be protected from unauthorised removal and from contamination. Close the mounting holes using the seals provided. The use of seals should be regarded as equivalent to using permanent fastenings in accordance with EN ISO 14119.

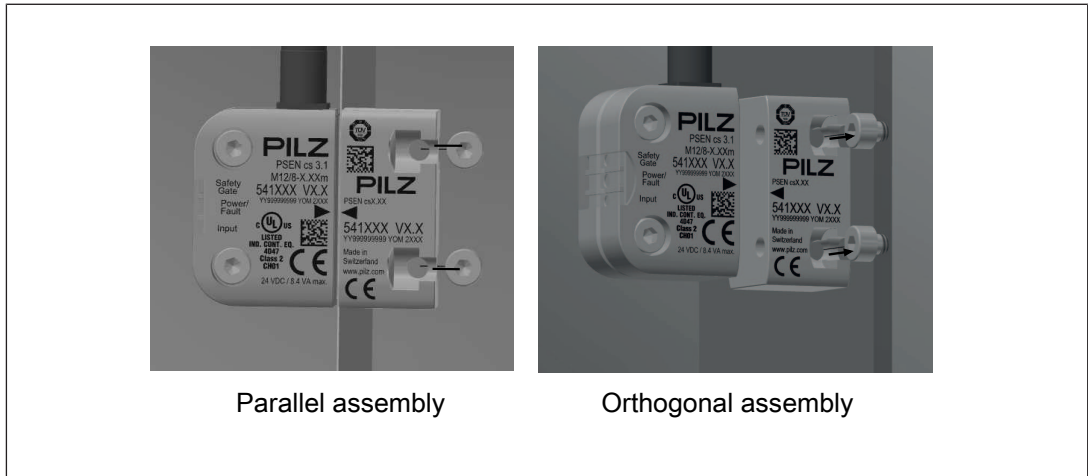

Procedure actuator PSEN cs1.1:

1. Use permanently secured M5 safety screws with a flat head (e.g. M5 cheese-head or pan head screws).
Provide the mounting surface with two drill holes for the screw connection of the actuator (see [Dimensions in mm](#) [ 23]).
2. Use two screws to fix the actuator in place. Align the actuator and tighten the screws.



Actuator cs3.1 low profile



WARNING!

Loss of the manipulation protection by inadequate environmental conditions

The loss of the manipulation protection can allow manipulation of the interlocking device and it may lead to serious injury or death.

- Make sure that the actuator has no direct or repetitive contact with materials such as methyl ethyl ketone (MEK), petrol or isopropanol.

- ▶ The actuator is secured against unauthorised removal, and against contamination by the sealing. The seal should be regarded as equivalent to using permanent fastenings in accordance with EN ISO 14119.
- ▶ By removing the actuator, the actuator will be destroyed.
- ▶ The actuator's adhesive force on the materials aluminium, stainless steel, polycarbonate and glass was checked. For deviating surface materials check the adhesive force on the surface.
- ▶ After a cure time of 24 hours, 90 % of the final adhesive force are achieved. The hardening must take place at min. 20 °C. With lower temperatures the cure time is clearly extended.
- ▶ No continuous force must affect the actuator.

Procedure actuator PSEN cs3.1 low profile glue

1. To seal the low profile actuators correctly, it is necessary to prepare the surface to which the actuator is to be attached.

The surface must be clean, dry and free of grease.

Wipe off any solved grease and contaminations with a new, dry paper cloth.

Clean the surface with 70% isopropanol. Use lint-free paper cloths and change the paper cloths frequently.

The adhesive surface is clean when the paper remains clean.

The cleaned surfaces must be sealed immediately to prevent any new contamination by dust and fingerprints.

2. Remove the protective foil from the assembly aid and fix it to the sensing area of the safety switch.
3. Place the actuator into the assembly aid so that the actuator's covered adhesive surface is on the surface.

Make sure that the actuator's centre is on the same level as the orientation arrows of the sensor and in the centre of the sensor.

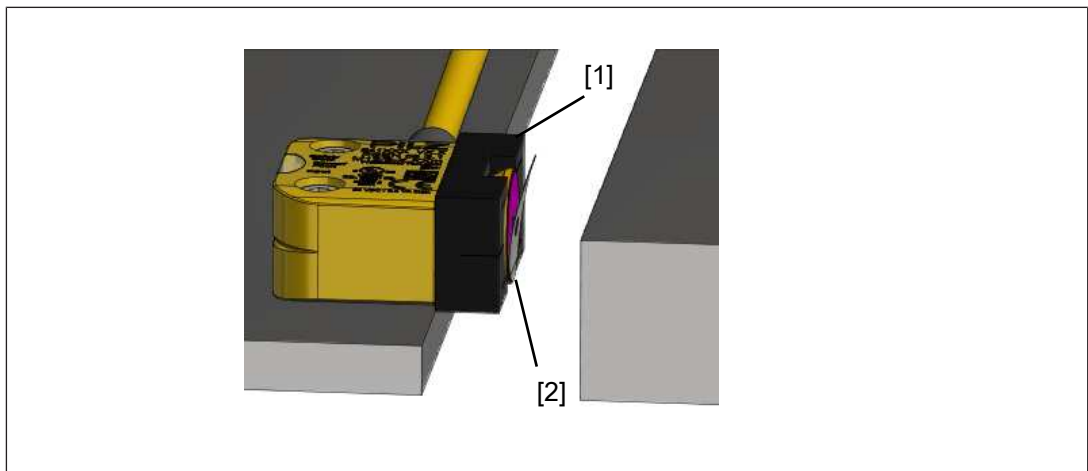

Fig.: Safety switch with assembly aid and low profile actuator

Legend

[1] Assembly aid for low profile actuator

[2] low profile actuator

4. Remove the protective foil from the adhesive foil of the actuator.
Do not touch the adhesive foil after removing the protective foil!
5. Close the safety gate carefully and then press the actuator to the adhesive position.
6. Press on the actuator for at least 3 seconds with approx. 50 N.
After this time, an adhesive force of approx. 50 % is achieved. The full adhesive force is achieved after 72 hours at an ambient temperature of at least 20 °C.

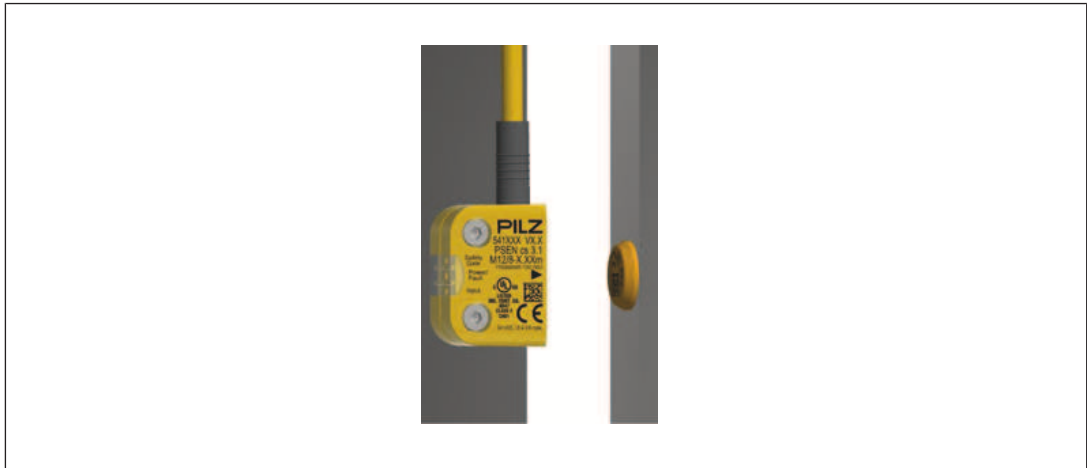

7. Check the adhesive force of the glue after 10 minutes.
The actuator must no move when pressed sideways.
8. Remove the assembly aid from the safety switch and clean the sensing area of the safety switch.

Procedure actuator PSEN cs3.1 low profile screw

1. Provide the mounting surface with a drill hole for an additional screw connection of the actuator (see [Dimensions in mm](#) 23]).
2. To seal the low profile actuators correctly, it is necessary to prepare the surface to which the actuator is to be attached.
The surface must be clean, dry and free of grease.
Wipe off any solved grease and contaminations with a new, dry paper cloth.
Clean the surface with 70% isopropanol. Use lint-free paper cloths and change the paper cloths frequently.
The adhesive surface is clean when the paper remains clean.
The cleaned surfaces must be sealed immediately to prevent any new contamination by dust and fingerprints.
3. Remove the protective foil from the assembly aid and fix it to the sensing area of the safety switch.
4. Place the actuator into the assembly aid so that the actuator's covered adhesive surface is on the surface.
Make sure that the actuator's centre is on the same level as the orientation arrows of the sensor and in the centre of the sensor.
5. Remove the protective foil from the adhesive foil of the actuator.
Do not touch the adhesive foil after removing the protective foil!
6. Insert the screw into the actuator's hole and position the screw at the hole on the mounting surface.
To screw on the actuator, use the supplied plastic M3 countersunk screw.
When using a screw mad from metal the operating distance change, please note the [Warning](#) 15].

7. Press on the actuator for at least 3 seconds with approx. 50 N.

After this time, an adhesive force of approx. 50 % is achieved. The full adhesive force is achieved after 72 hours at an ambient temperature of at least 20 °C.

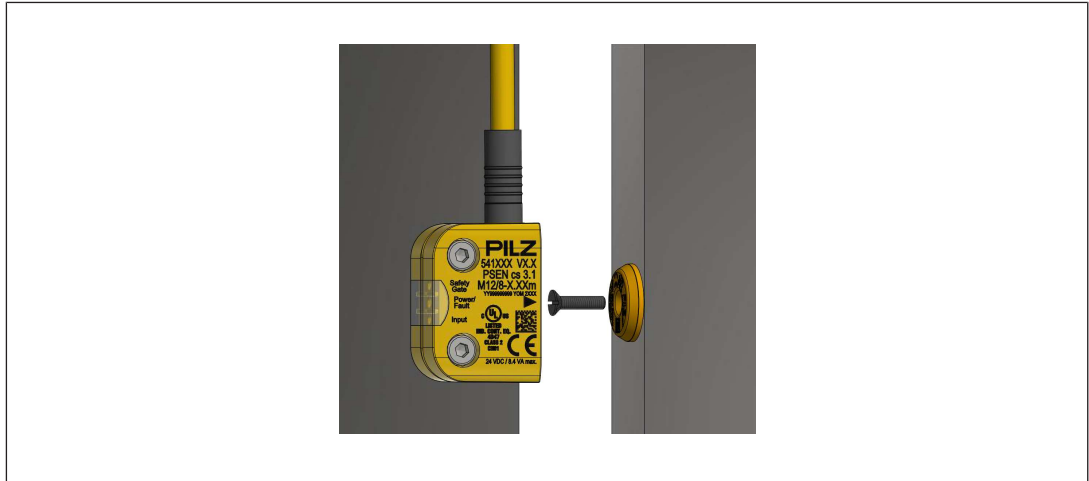

8. Check the adhesive force of the glue after 10 minutes.
The actuator must not move when pressed sideways.
9. Tighten the M3 plastic screw to 0,8 Nm.

Align safety switch and actuator

Procedure:

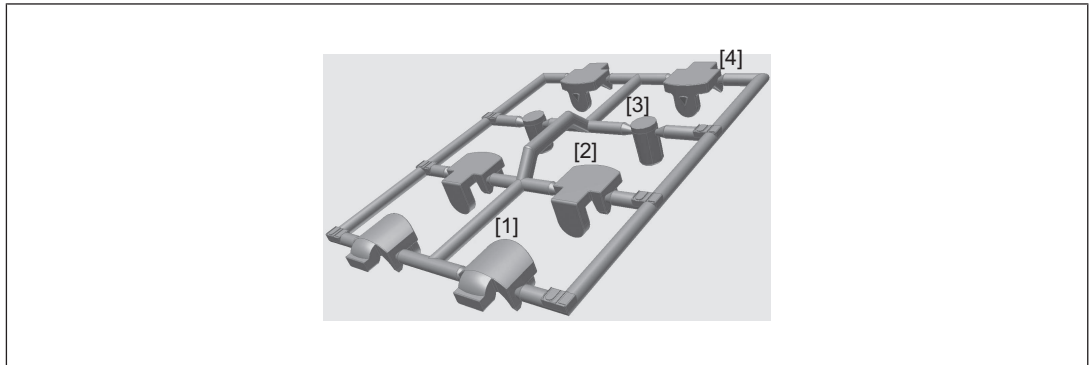

1. Align the safety switch and tighten the screws.
2. Actuator PSEN cs3.1
Align the actuator and tighten the screws.
3. Close the mounting holes using the seals provided (see diagram).
Use the seals [1] for UL approval or [4] without UL approval.



Legend

- [1] Side seal with UL approval
 - [2] Bottom seal
 - [3] Top seal, sensing side
 - [4] Side seal without UL approval
4. Use the seals to close the mounting holes on the sensing face of the safety switch (see diagram, [3]).
 5. If necessary, use the seals to close the unused mounting holes on the actuator (see diagram, [2]).

Adjustment

- ▶ The stated operating distances (see [Technical details](#)  26]) only apply when the safety switch and actuator are installed facing each other in parallel. Operating distances may deviate if other arrangements are used.
- ▶ Note the maximum permitted lateral and vertical offset (see [Operating distances](#)  10] and [Lateral and vertical offset](#)  10]).

Operation



NOTICE

The safety function should be checked after initial commissioning and each time the plant/machine is changed. The safety functions may only be checked by qualified personnel.

Status indicators:

- ▶ "Power/Fault" LED lights up green: The unit is ready for operation
- ▶ "Safety Gate" LED lights up yellow: Actuator is within the response range
- ▶ "Input" LED lights up yellow: There is a high signal at both inputs

Fault indicator:

- ▶ "Input" LED lights up yellow: the signal switches from high to low at one input, while a high signal remains on the other input (partial operation).
Remedy: Open both channels of the input circuit.
- ▶ "Power/Fault" LED lights up red: Error message
Remedy: Rectify fault and interrupt power supply.

Dimensions in mm

Safety switch PSEN cs3.1n

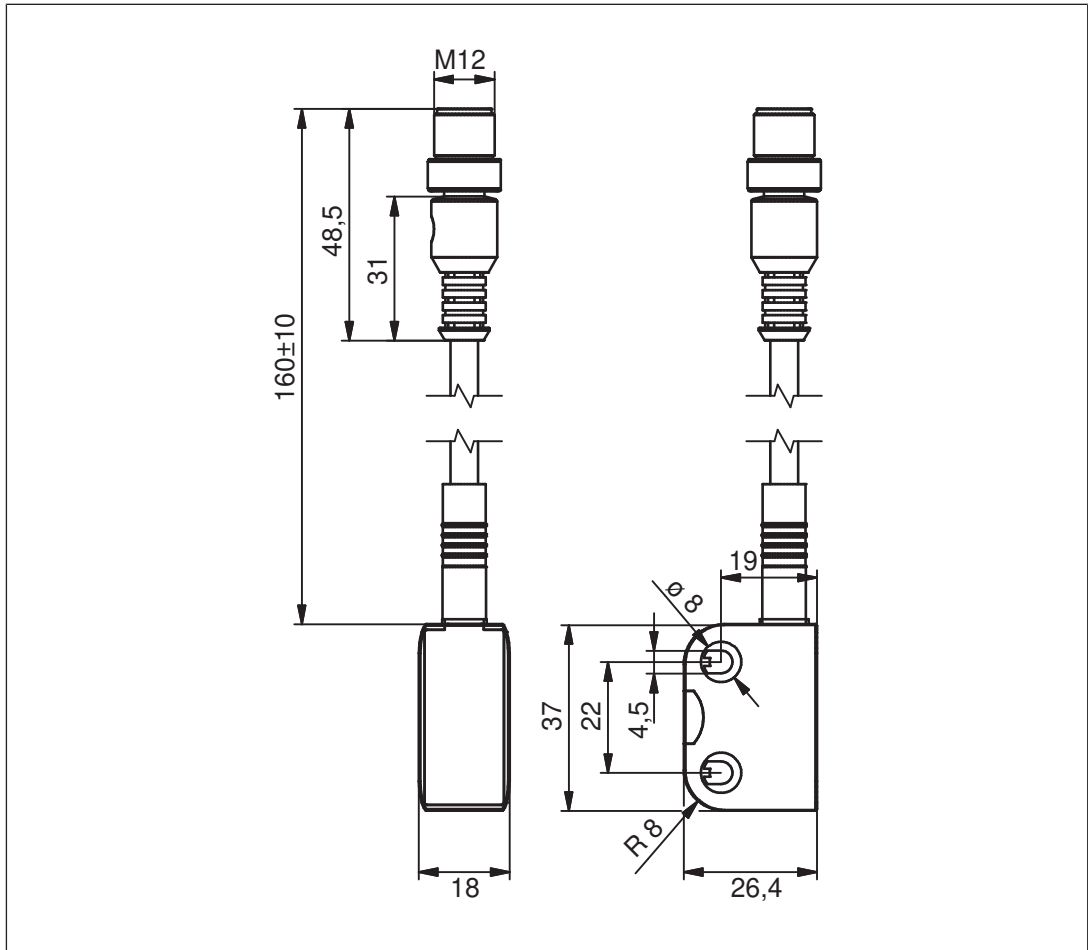

Actuator

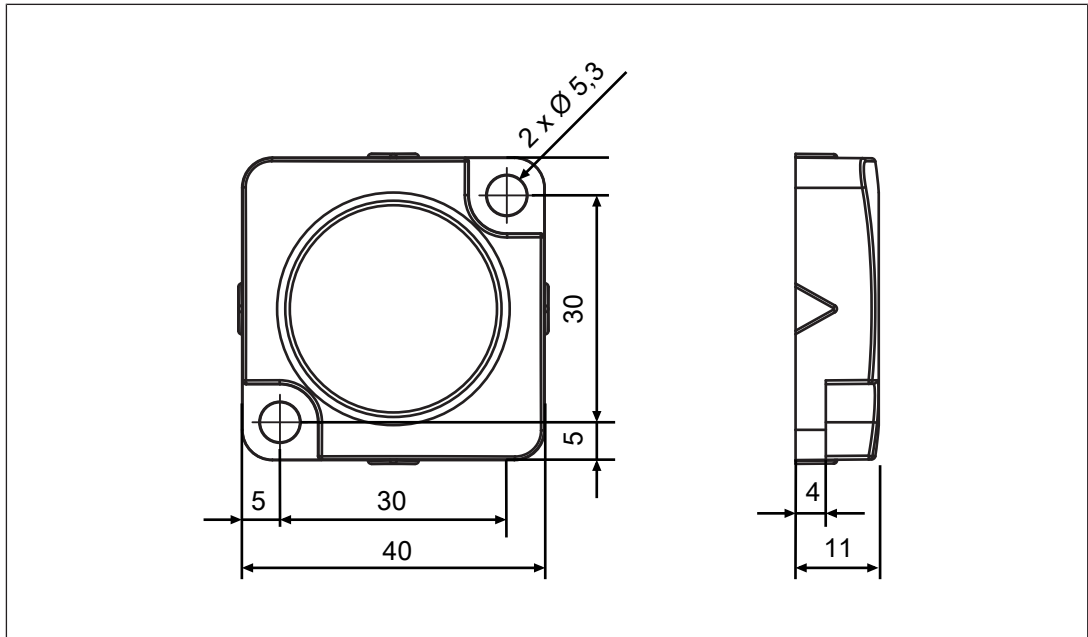

Fig.: Actuator PSEN cs1.1

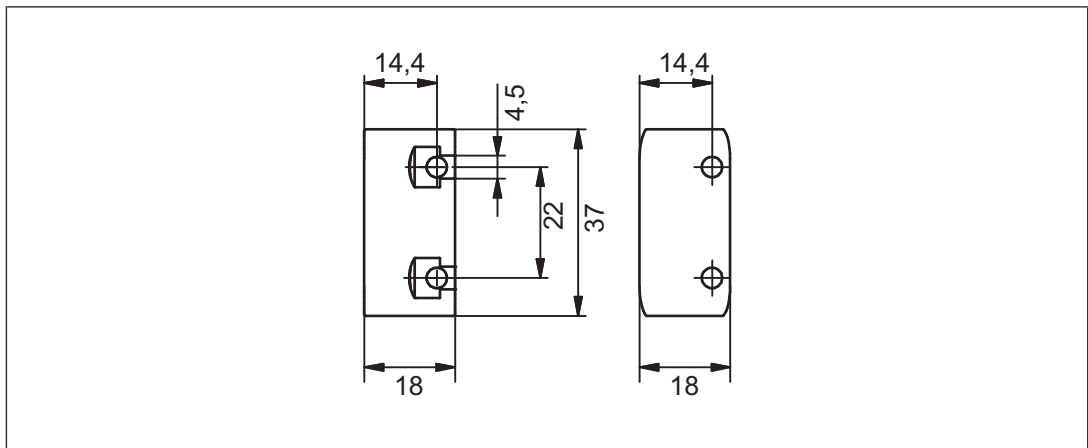
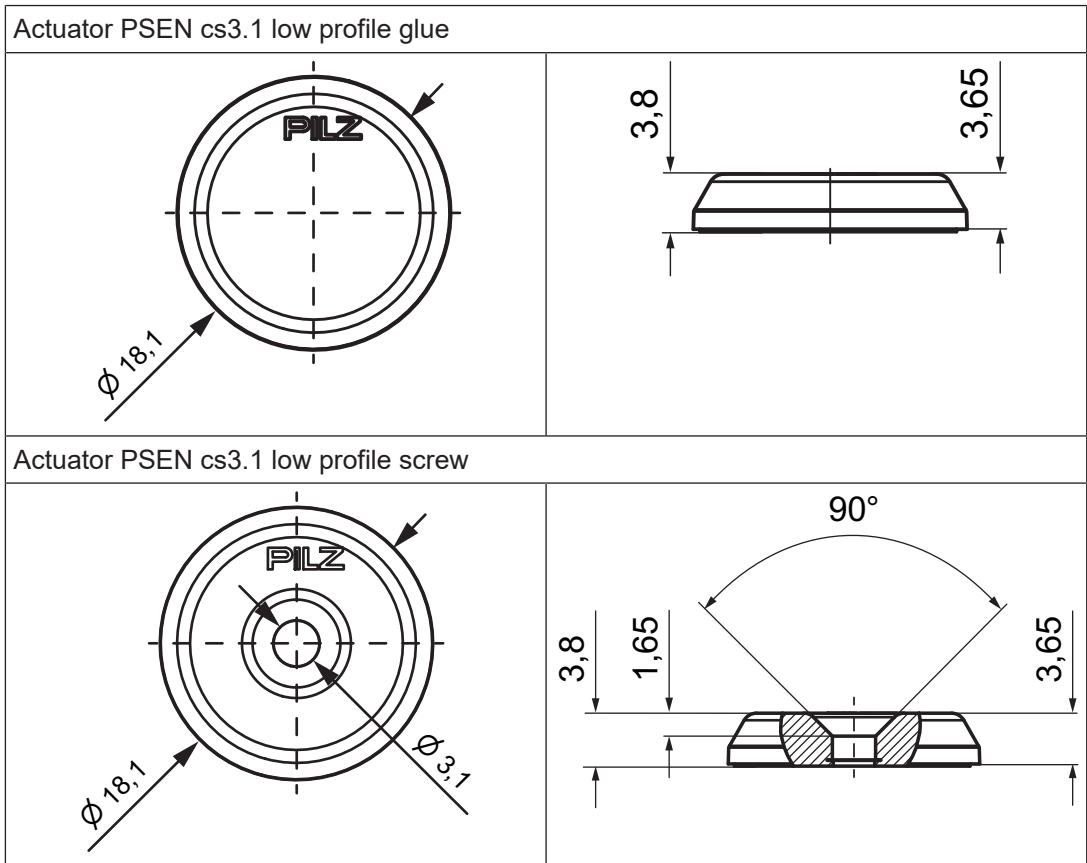

Fig.: Actuator PSEN cs3.1



Technical details safety switch

General	
Certifications	CE, EAC (Eurasian), FCC, IC, TÜV, cULus Listed
Sensor's mode of operation	Transponder
Coding level in accordance with EN ISO 14119	Low
Design in accordance with EN ISO 14119	4
Classification in accordance with EN 60947-5-3	PDDB
Pilz coding type	Coded
Transponder	
Frequency band	122 kHz - 128 kHz
Max. transmitter output	15 mW
Electrical data	
Supply voltage	
Voltage	24 V
Kind	DC
Voltage tolerance	-20 %/+20 %
Output of external power supply (DC)	1 W
Max. switching frequency	3 Hz
Max. cable capacitance at the safety outputs	
No-load, PNOZ with relay contacts	400 nF
PNOZmulti, PNOZelog, PSS	400 nF
Max. inrush current impulse	
Current pulse, A1	0,58 A
Pulse duration, A1	1 ms
No-load current	20 mA
Semiconductor outputs	
OSSD safety outputs	2
Signal outputs	1
Switching current per output	100 mA
Breaking capacity per output	2,4 W
Potential isolation from system voltage	No
Short circuit-proof	yes
Residual current at outputs	20 µA
Voltage drop at OSSDs	3,5 V
Lowest operating current	0 mA
Utilisation category in accordance with EN 60947-1	DC-12
Times	
Test pulse duration, safety outputs	450 µs
Switch-on delay	
after UB is applied	1 s
Actuator typ.	60 ms
Actuator max.	150 ms

Times

Delay-on de-energisation

Actuator typ.	40 ms
Actuator max.	260 ms

Risk time in accordance with EN 60947-5-3	260 ms
---	---------------

Supply interruption before de-energisation	10 ms
--	--------------

Simultaneity, channel 1 and 2 max.	∞
------------------------------------	----------

Environmental data

Ambient temperature

In accordance with the standard	EN 60068-2-14
Temperature range	-25 - 70 °C

Storage temperature

In accordance with the standard	EN 60068-2-1/-2
Temperature range	-25 - 70 °C

Climatic suitability

In accordance with the standard	EN 60068-2-78
Humidity	93 % r. h. at 40 °C

EMC	EN 60947-5-3
-----	---------------------

Vibration

In accordance with the standard	EN 60947-5-2
Frequency	10 - 55 Hz
Amplitude	1 mm

Shock stress

In accordance with the standard	EN 60947-5-2
Acceleration	30g
Duration	18 ms

Airgap creepage

Overvoltage category	III
Pollution degree	3

Rated insulation voltage	75 V
--------------------------	-------------

Rated impulse withstand voltage	0,8 kV
---------------------------------	---------------

Protection type

Housing	IP6K9K
Connector	IP67

Operating distances

Actuator 1

Type	PSEN cs3.1
Assured operating distance S_{ao}	8 mm
Typical operating distance S_o	11 mm
Assured release distance S_{ar}	20 mm
Typical release distance S_r	14 mm
Repetition accuracy switching distances	10 %
Change of operating distance with temperature changes	+0,01mm/°C
Typ. Hysteresis	2 mm

Operating distances

Actuator 2

Type	PSEN cs1.1
Assured operating distance S_{ao}	10 mm
Typical operating distance S_o	25 mm
Assured release distance S_{ar}	33 mm
Typical release distance S_r	29 mm
Repetition accuracy switching distances	10 %
Change of operating distance with temperature changes	+0,1mm/°C
Typ. Hysteresis	3 mm

Actuator 3

Type	PSEN cs3.1 low profile glue
Assured operating distance S_{ao}	5 mm
Typical operating distance S_o	10 mm
Assured release distance S_{ar}	20 mm
Typical release distance S_r	12 mm
Repetition accuracy switching distances	10 %
Change of operating distance with temperature changes	+0,01mm/°C
Typ. Hysteresis	2 mm

Actuator 4

Typ	PSEN cs3.1 low profile screw
Assured operating distance S_{ao}	5 mm
Typical operating distance S_o	10 mm
Assured release distance S_{ar}	20 mm
Typical release distance S_r	12 mm
Repetition accuracy switching distances	10 %
Change of operating distance with temperature changes	+0,01mm/°C
Typical hysteresis	2 mm

Mechanical data

Min. bending radius (fixed permanently) K1	5 x Ø
Min. bending radius (moving) K1	10 x Ø
Cable diameter K1	5,55 mm
Min. distance between safety switches	100 mm
Sensor flush installation in accordance with EN 60947-5-2	Yes, follow installation guidelines
Connection type	M12, 5-pin male connector
Cable	Li9Y11Y 8 x 0,14 mm²
Material	
Top	PBT
Max. torque setting for fixing screws	0,8 Nm
Dimensions	
Height	37 mm
Width	26 mm
Depth	18 mm

Mechanical data

Weight of safety switch	40 g
-------------------------	-------------

Where standards are undated, the 2016-10 latest editions shall apply.

Technical details actuator

Order no. 540080 - 541080

See below for more order numbers

General	540080	541080
Certifications	CE, EAC (Eurasian), TÜV, cULus Listed	CE, EAC (Eurasian), TÜV, cULus Listed
Sensor's mode of operation	Transponder	Transponder
Coding level in accordance with EN ISO 14119	Low	Low
Pilz coding type	Coded	Coded
Transponder	540080	541080
Frequency band	122 kHz - 128 kHz	122 kHz - 128 kHz
Environmental data	540080	541080
Ambient temperature		
In accordance with the standard	EN 60068-2-14	EN 60068-2-14
Temperature range	-25 - 70 °C	-25 - 70 °C
Storage temperature		
In accordance with the standard	EN 60068-2-1/-2	EN 60068-2-1/-2
Temperature range	-40 - 85 °C	-25 - 70 °C
Climatic suitability		
In accordance with the standard	EN 60068-2-78	EN 60068-2-78
Humidity	93 % r. h. at 40 °C	93 % r. h. at 40 °C
EMC	EN 60947-5-3	EN 60947-5-3
Vibration		
In accordance with the standard	EN 60947-5-2	EN 60947-5-2
Frequency	10 - 55 Hz	10 - 55 Hz
Amplitude	1 mm	1 mm
Shock stress		
In accordance with the standard	EN 60947-5-2	EN 60947-5-2
Acceleration	30g	30g
Duration	11 ms	18 ms
Protection type		
Housing	IP6K9K	IP6K9K
Mechanical data	540080	541080
Material	–	PBT
Material		
Top	PBT	–
Max. torque setting for fixing screws	1 Nm	0,8 Nm

Mechanical data	540080	541080
Dimensions		
Height	11 mm	37 mm
Width	40 mm	18 mm
Depth	40 mm	18 mm
Weight	20 g	10 g

Order no. 541087 - 541088

General	541087	541088
Certifications	CE, EAC (Eurasian), TÜV, cULus Listed	CE, EAC (Eurasian), TÜV, cULus Listed
Sensor's mode of operation	Transponder	Transponder
Coding level in accordance with EN ISO 14119	Low	Low
Pilz coding type	Coded	Coded

Transponder	541087	541088
Frequency band	122 kHz - 128 kHz	122 kHz - 128 kHz

Environmental data	541087	541088
Ambient temperature		
In accordance with the standard	EN 60068-2-14	EN 60068-2-14
Temperature range	-25 - 70 °C	-25 - 70 °C
Max. at max. operating height	+60 °C	+60 °C
Max. at max. operating height <2000 m	+70 °C	+70 °C
Storage temperature		
In accordance with the standard	EN 60068-2-1/-2	EN 60068-2-1/-2
Temperature range	-40 - 85 °C	-40 - 85 °C
Climatic suitability		
In accordance with the standard	EN 60068-2-30	EN 60068-2-30
Humidity	93 % r. h. at 40 °C	93 % r. h. at 40 °C
Max. operating height above sea level	4000 m	4000 m
EMC	EN 60947-5-3	EN 60947-5-3
Vibration		
In accordance with the standard	EN 60947-5-2	EN 60947-5-2
Frequency	10 - 55 Hz	10 - 55 Hz
Amplitude	1 mm	1 mm
Shock stress		
In accordance with the standard	EN 60947-5-2	EN 60947-5-2
Acceleration	30g	30g
Duration	11 ms	11 ms
Protection type		
Housing	IP67	IP67
Mechanical data	541087	541088
Material		
Top	PBT	PBT

Mechanical data	541087	541088
Max. torque setting for fixing screws	–	0,1 Nm
Dimensions		
Height	3,8 mm	3,8 mm
Width	18 mm	18 mm
Depth	18 mm	18 mm
Weight	2 g	2 g

Where standards are undated, the 2016-10 latest editions shall apply.

Classification according to ZVEI, CB24I

The following tables describe the classes and specific values of the product interface and the classes of interfaces compatible with it. The classification is described in the ZVEI position paper "Classification of Binary 24 V Interfaces - Functional Safety aspects covered by dynamic testing".

Single-pole output	
Interfaces	
Source	
Interface	Sensor
Class	C2
Drain	
Class	C1, C2
Source parameters	
Max. test pulse duration	450 µs
Max. rated current	0,1 A
Max. capacitive load	0,4 µF

Safety characteristic data



NOTICE

You must comply with the safety characteristic data in order to achieve the required safety level for your plant/machine.

Operating mode	EN ISO 13849-1: 2015 PL	EN ISO 13849-1: 2015 Category	EN 62061 SIL CL	EN 62061 PFH _D [1/h]	IEC 61511 SIL	IEC 61511 PFD	EN ISO 13849-1: 2015 T _M [year]
2-ch. OSSD	PL e	Cat. 4	SIL CL 3	2,62E-09	–	7,68E-05	20

Explanatory notes for the safety-related characteristic data:

- ▶ The SIL CL value in accordance with EN 62061 corresponds to the SIL value in accordance with EN 61508.
- ▶ T_M is the maximum mission time in accordance with EN ISO 13849-1. The value also applies as the retest interval in accordance with EN 61508-6 and IEC 61511 and as the proof test interval and mission time in accordance with EN 62061.

All the units used within a safety function must be considered when calculating the safety characteristic data.



INFORMATION

A safety function's SIL/PL values are **not** identical to the SIL/PL values of the units that are used and may be different. We recommend that you use the PASCAL software tool to calculate the safety function's SIL/PL values.

Supplementary data

Radio approval

USA/Canada
 FCC ID: VT8-PSENCSS3 IC: 7482A-PSENCSS3
<p><u>FCC/IC-Requirements:</u> This product complies with Part 15 of the FCC Rules and with Industry Canada licence-exempt RSS standards. Operation is subject to the following two conditions: 1) this product may not cause harmful interference, and 2) this product must accept any interference received, including interference that may cause undesired operation.</p> <p>Changes or modifications made to this product not expressly approved by Pilz may void the FCC authorization to operate this equipment.</p> <p>NOTE: This equipment has been tested and found to comply with the limits for a Class A digital device, pursuant to Part 15 of the FCC Rules. These limits are designed to provide reasonable protection against harmful interference when the equipment is operated in a commercial environment. This equipment generates, uses, and can radiate radio frequency energy and, if not installed and used in accordance with the instruction manual, may cause harmful interference to radio communications. Operation of this equipment in a residential area is likely to cause harmful interference in which case the user will be required to correct the interference at his own expense.</p> <p>Le présent produit est conforme aux CNR d'Industrie Canada applicables aux appareils radio exempts de licence. L'exploitation est autorisée aux deux conditions suivantes: (1) le produit ne doit pas produire de brouillage, et (2) l'utilisateur de le produit doit accepter tout brouillage radioélectrique subi, même si le brouillage est susceptible d'en compromettre le fonctionnement.</p>

Order reference

Safety switch

Product type	Features		Order no.
PSEN cs3.1n 1switch	Safety switch, coded	5-pin M12 connector	541 053

Actuator

Product type	Features		Order no.
PSEN cs1.1 1 actuator	Actuator, coded		540 080
PSEN cs3.1 1 actuator	Actuator, coded		541 080
PSEN cs3.1 low profile glue 1 actuator	Actuator coded, without screw		541 087
PSEN cs3.1 low profile screw 1 actuator	Actuator coded, with screw		541 088

Complete systems

Product type	Features		Order no.
PSEN cs3.1n / PSEN cs3.1 1 Unit	Safety gate system, coded	5-pin M12 connector	541 003

Accessories

Installation materials

Product type	Features	Order no.
PSEN bracket	Mounting bracket	532 110
PSEN mag/cs bracket straight	Mounting aid	532 111
PSEN screw M4x20 10pcs	Safety screws made from stainless steel with one-way slot	540 313
PSEN screw M4x26 10pcs	Safety screws made from stainless steel with one-way slot	540 314
PSEN screw M5x10 10pcs	Safety screws made from stainless steel with one-way slot	540 311
PSEN screw M5x20 10pcs	Safety screws made from stainless steel with one-way slot	540 312
PSEN cs1/2 bracket cable fix	Mechanical protection against defeat, protecting against unauthorised cable disconnection or damage for safety switches PSENcode cs1/2, PSENcode cs5/6 M12, PSENslock	532 112

Cable

Product type	Connection 1	Connection 2	Length	Order No.
PSS67/PDP67 cable M12-5sf	Straight, M12, 5-pin, socket	Straight, M12, 5-pin, connector	3 m	380 208
			5 m	380 209
			10 m	380 210
			20 m	380 220
			30 m	380 211
PSS67/PDP67 cable M12-5af	Angled, M12, 5-pin, socket	Angled, M12, 5-pin, connector	3 m	380 212
			5 m	380 213
			10 m	380 214
			30 m	380 215
PSEN cable M12-5sf	Straight, M12, 5-pin, socket	Open cable	3 m	630 310
			5 m	630 311
			10 m	630 312
			20 m	630 298
			30 m	630 297
PSEN cable M12-5af	Angled, M12, 5-pin, socket	Open cable	3 m	630 347
			5 m	630 348
			10 m	630 349
			30 m	630 350
PDP67 F 8DI ION	Decentralised input module IP67 for PNOZmulti			773 600

EC declaration of conformity

This product/these products meet the requirements of the following directives of the European Parliament and of the Council.

- ▶ 2006/42/EC on machines
- ▶ 2014/53/EC on radio equipment

The complete EC Declaration of Conformity is available on the Internet at www.pilz.com/downloads.

Representative: Norbert Fröhlich, Pilz GmbH & Co. KG, Felix-Wankel-Str. 2, 73760 Ostfildern, Germany

► Support

Technical support is available from Pilz round the clock.

Americas

Brazil
+55 11 97569-2804

Canada
+1 888 315 7459

Mexico
+52 55 5572 1300

USA (toll-free)
+1 877-PILZUSA (745-9872)

Asia

China
+86 21 60880878-216

Japan
+81 45 471-2281

South Korea
+82 31 778 3300

Australia

+61 3 95600621

Europe

Austria
+43 1 7986263-0

Belgium, Luxembourg
+32 9 3217570

France
+33 3 88104003

Germany
+49 711 3409-444

Ireland
+353 21 4804983

Italy, Malta
+39 0362 1826711

Scandinavia

+45 74436332

Spain

+34 938497433

Switzerland

+41 62 88979-32

The Netherlands

+31 347 320477

Turkey

+90 216 5775552

United Kingdom

+44 1536 462203

You can reach our international hotline on:

+49 711 3409-444
support@pilz.com

Pilz develops environmentally-friendly products using ecological materials and energy-saving technologies. Offices and production facilities are ecologically designed, environmentally-aware and energy-saving. So Pilz offers sustainability, plus the security of using energy-efficient products and environmentally-friendly solutions.

Energy
saving by Pilz



We are represented internationally. Please refer to our homepage www.pilz.com for further details or contact our headquarters.

Headquarters: Pilz GmbH & Co. KG, Felix-Wankel-Straße 2, 73760 Ostfildern, Germany
Telephone: +49 711 3409-0, Telefax: +49 711 3409-133, E-Mail: info@pilz.com, Internet: www.pilz.com

PILZ
THE SPIRIT OF SAFETY

22172-EN-06, 2020-03 Printed in Germany
© Pilz GmbH & Co. KG, 2019

CECC® , CHRE® , CMSE® , InduraNET p® , Leansafe® , Master of Safety® , Master of Security® , PAS4000® , PAScall® , PASconfig® , Pilz® , PTT® , PLID® , PMCPirimo® , PMCPiritego® , PMCTendo® , PMD® , PMJ® , PNOZ® , PRBT® , PRCM® , PRCM® , PSEN® , PSEN® , PSS® , PVS® , SafetyBUS p® , SafetyEYE® , SafetyNET p® , THE SPIRIT OF SAFETY® are registered and protected trademarks of Pilz GmbH & Co. KG in some countries. We would point out that product features may vary from the details stated in this document, depending on the status at the time of publication and the scope of the equipment. We accept no responsibility for the validity, accuracy and entirety of the text and graphics presented in this information. Please contact our Technical Support if you have any questions.