

Reliably safeguard your most valuable assets.



Flame and Gas Safety Solutions

Integrated technologies to protect personnel and property while maintaining profitable operation.



Dependable Safety Systems from Emerson — Your Automation Solutions Partner.

No matter how extreme or demanding the conditions, your people and facilities come first. That is why Emerson is dedicated to offering the most comprehensive and advanced flame and gas detection technologies available. Our flame and gas monitoring systems are designed to excel under the toughest conditions to help you streamline day-to-day operations and, more importantly, keep your people safe.

The fatality rate from exposure to harmful environments/
substances was 8.7 percent in the oil & gas industry from 2003-2013.
- The Centers for Disease Control (CDC)



“Fires and explosions were the fourth most common cause for severe
injuries, after falls and being struck by objects [in the upstream oil
and gas industry].”^{*}
- Environment & Energy NEWS



Fires and explosions caused 14.3 percent of fatalities that occurred
in the oil and gas extraction industry between 2003-2013.
- The Centers for Disease Control (CDC)



“Leak or break was a factor contributing to ignition for 28 percent of
non-home structure fires starting with flammable gas.”^{**}
- National Fire Protection Association (NFPA)



^{*} “Oil and Gas Industry Leads in Severe Injuries” Environment & Energy NEWS

^{**} “Structure Fires Started by Hot Work” National Fire Protection Association (NFPA)





Emerson's full offering of industrial flame and gas detection systems provides best-in-class specifications with low overall life cycle costs.

Rosemount™ 928 Wireless Gas Monitor



Product Overview

The Rosemount 928 Wireless Gas Monitor continuously monitors for the presence of toxic and combustible gases in remote, difficult-to-reach locations. This wireless gas monitoring system enhances worker safety through early gas leak detection and eliminates the need for expensive wiring. Device approvals include Intrinsically Safe, CSA Division 1, and ATEX/IECEx Zone 0.

Features:

- Universal transmitter
- Simple *WirelessHART*® network integration
- Extended battery life
- Wide operating temperature range
- Intuitive local indicator
- Tool-less battery and sensor replacement
- Hot-swappable power module

[Emerson.com/Rosemount928](https://emerson.com/Rosemount928)

What's your challenge?



Conventional wired gas detectors can be expensive to implement in remote locations that require high costs of installing wiring for power and communication.

What's your opportunity?



You can eliminate expensive wiring by installing a wireless gas monitor instead of a traditional wired fixed point gas detector. This would save an estimated 60 percent in initial equipment installation cost and 90 percent in upfront installation labor cost.



Rosemount 628 Universal Gas Sensor

The Rosemount 628 Universal Gas Sensor easily connects to the Rosemount 928 Wireless Gas Monitor. Gas sensor types include hydrogen sulfide (H₂S), carbon monoxide (CO), and oxygen depletion (O₂).

Features:

- Tool-less hot-swappable smart sensor
- Lab calibration reduces labor costs
- Suitable for use in harsh environments
- Quick connect design

[Emerson.com/Rosemount628](https://emerson.com/Rosemount628)

Wired Fixed Point Gas Detectors

Universal Transmitters

Millennium II Single Channel Gas Detector



This single channel universal transmitter contains an easy to read OLED display. It is also HART® 7 capable with a full suite of diagnostics and intuitive menu system.

Millennium II Dual Channel Gas Detector



With dual channel measurements, a single universal transmitter can measure two different types of gases. This reduces upfront costs since only one transmitter device is installed and commissioned.

Millennium II Basic Single Channel Gas Detector



This universal transmitter is designed for demanding, industrial applications that require a local, full-featured transmitter interface but do not require a character display.

Universal Sensors

Millennium II ST3 XChem Toxic Gas Sensor

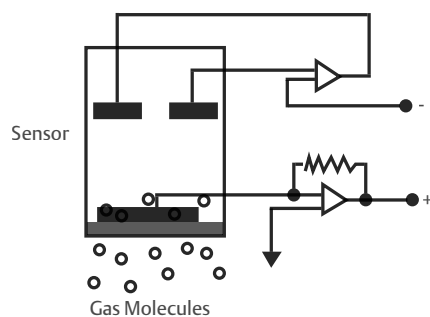

This dependable electrochemical sensor provides high specificity, fast response time, is easy to calibrate, and has a long life. This sensor produces more current as gas comes into contact with it.

Millennium II SC311 Infrared Combustible Gas Sensor

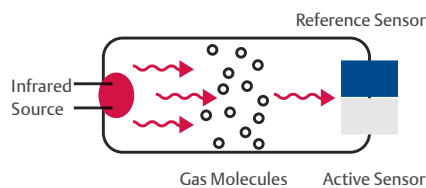

The SC311 uses infrared sensor technology based on Beer-Lambert law, which measures the light being absorbed by flammable gas. This sensor is designed for extreme industrial environments and can withstand long periods between calibrations.

Millennium II SC310 Catalytic Bead Combustible Gas Sensor

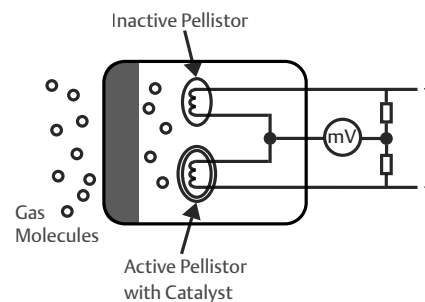

The SC310 provides versatile, robust, and field proven performance with the added feature of hydrogen gas detection. This catalytic bead sensor is self-compensating to environmental changes. Additionally, it is easy to install, calibrate, and operate.



Flame Detectors

The Rosemount 975 Flame Detector Series detect fuel and gas fires at long distances with the highest immunity to false alarms. These detectors rely on line-of-site detection of the radiation emitted in the spectral bands to determine if a flame is real. Depending on the device, it can reliably detect hydrocarbon-based fuel and gas flames as well as hydrogen flames. All flame detector models feature heated optics, automatic built-in-test, false alarm immunity, and real time diagnostics.

[Emerson.com/FlameDetectors](https://www.emerson.com/FlameDetectors)

What's your challenge?



Combustible material releases, if ignited, can quickly engulf a facility endangering personnel and damaging property. Many facilities contain a wide range of combustible substances with different fire properties that must be taken into account for a full protection scheme.



What's your opportunity?

Optical flame detectors detect hydrocarbon and hydrogen flames that may be present at a plant. Rosemount flame detectors are built with a high-speed response and can be configured to detect flames from a variety of fuel sources. Rosemount 975 flame detectors have an 80 percent decrease in response time and a 31 percent increase in area coverage compared to traditional devices.

	Rosemount 975MR Multi-Spectrum Infrared Flame Detector	Rosemount 975UR Ultraviolet Infrared Flame Detector	Rosemount 975UF Ultra Fast Ultraviolet Infrared Flame Detector	Rosemount 975HR Multi-Spectrum Infrared Hydrogen Flame Detector
Detects Hydrocarbon Gas or Liquid Flames	●	●	●	●
Detects Hydrogen Flames			●	●
Detects Ammonia, Metal Oxides, Silane, and Other Non-Organic Fuels			●	
Unaffected by Solar Radiation	●	●	●	●
Immunity to False Alarms	●	●	●	●
5 s Response Time	●	●		●
3 s Response Time			●	
20 ms Flash Fire Response Time			●	
100° Horizontal / 90° Vertical Hydrocarbon Field of View	●	●	●	
80° Horizontal / 80° Vertical Field of View				●
Maximum Detection Range	215 ft (65 m)	93 ft (28 m)	66 ft (20 m)	215 ft (65 m)



Open Path Gas Detectors



SafEye Quasar 900 Open Path Combustible Gas Detector

- Detects hydrocarbon gases
- Utilizes infrared technology
- Long range detection up to 660 ft (200 m)



SafEye Quasar 950 & 960 Open Path Toxic Gas Detectors

- Detects hydrogen sulfide (H₂S) or ammonia (NH₃)
- Utilizes ultraviolet technology
- Long range detection up to 200 ft (60 m)

The SafEye Quasar Series Open Path Gas Detectors provide continuous monitoring for combustible and toxic gases, even in harsh environments where dust, fog, rain, snow or vibration can cause a high reduction of signal. Worldwide approvals for these devices include ATEX, IECEx, FM/FMC, INMETRO, TR CU, and SIL 2 (TÜV).

Features:

- Accurate, high-speed response (< 3 seconds)
- High immunity to false alarms
- Heated optics for use in extreme environments
- Built-in data logger (records up to 100 events)
- Real time diagnostics
- Reduced cross sensitivity
- Factory calibrated gas settings

[Emerson.com/OpenPathDetectors](https://www.emerson.com/OpenPathDetectors)

What's your challenge?



Fence line monitoring with conventional technologies can be costly and highly affected by environmental conditions.

What's your opportunity?



You can decrease device costs by purchasing fewer open path detectors for a large coverage area. This provides a substantial amount of equipment savings and requires fewer devices to be commissioned. It also reduces electrical wiring time and cost.



Incus Ultrasonic Gas Leak Detector



The Incus Ultrasonic Gas Leak Detector is specifically designed to detect gas leaks at the speed of sound while providing wide area coverage. The technology works by responding to the acoustic noise created by a pressurized gas leak. Common high-pressure applications include air cooled heat exchangers, compressor stations, generators, gas metering skids, well bay areas, and separators. This device is unaffected by inclement weather, wind, leak direction, and gas dilution or stratification. Device approvals include IECEx, ATEX, c FM us, EAC, KOSHA, INMETRO, ABS, and DNV.

[Emerson.com/Incus](https://www.emerson.com/Incus)

What's your challenge?



Rapid detection of leaks in high pressure processes, such as pipeline monitoring or gas compressor stations, is critical for safe operation. These applications are often exposed to environmental conditions and located in remote areas.

What's your opportunity?



Ultrasonic gas leak detectors provide rapid detection response time for pressurized toxic gas, combustible gas, inert gases, and vapors. Because these devices monitor for ultrasonic noise, they are unaffected by wind, rain, or other conditions.

Gas & Smoke Aspirator System

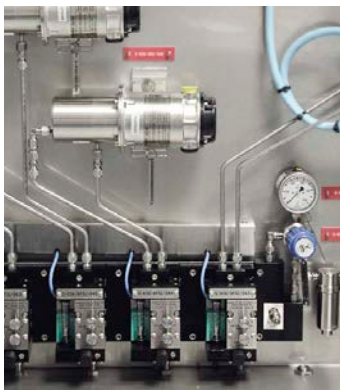

The Gas & Smoke Aspirator System is a unique solution to accurately monitor gas and/or smoke ingress in areas where it is not practical to place a detector. Aspirator systems detect specific components in a gas stream flowing through a duct by taking a sample of the gas and sending it to an external instrument for measurement. External monitoring provides much higher reliability than the in situ approach because the instrument sensor and transmitter are mounted outside of the duct. This reduces the cost of the measurement device and extends the life of the instrument's sensor since it is not exposed to high heat or humidity.

Features:

- Requires only instrument air to operate
- Compatible with wide range of detectors
- Simplified plumbing and compact design

[Emerson.com/RosemountAspirator](https://www.emerson.com/RosemountAspirator)

What's your challenge?



Gas sensors inserted into extreme environments, such as high heat, may lose sensitivity and response speed over time. As a result, these sensors often need to be replaced before a facility can continue to operate, leading to unplanned shutdowns.



What's your opportunity?

With an aspirator or piping system, sample gas may be pulled to a remote gas detector after the sample is conditioned. As a result, the sensors operate for several years and do not require unplanned shutdowns during replacement.

The Air Particle Monitor is the only infrared optical monitor that is certified for use in hazardous areas for constant, reliable monitoring of ambient air for particulates such as oil mist, carbon, dust, and ash. Oil mist detection is a commonly overlooked hazard related to gas turbine and engine room monitoring as many more fires are produced by oil mist than by gas releases. Although these areas are fitted with gas detectors, very few have combustible liquid detectors.



Features:

- Explosion-proof for use in hazardous areas
- High temperature tolerance
- Resilient to environmental fouling
- Field adjustable sensitivity settings

[Emerson.com/RosemountAPM](https://www.emerson.com/RosemountAPM)



What's your challenge?



Industrial facilities powered by natural gas or diesel can experience pressurized leaks that create atomized fuel or lube oil. These leaks could lead to fires or explosions if the released liquid makes contact with a hot operating surface.

What's your opportunity?



The air particle monitor provides you with the ability to accurately and reliably detect atomized fuel or lube oil particulates.

Engineered to perform in the most challenging conditions on earth!



Emerson Automation Solutions
6021 Innovation Blvd.
Shakopee, MN 553379
USA
T +1 866 347 3427

Emerson Automation Solutions
Neuhofstrasse 19a P.O. Box
1046 CH 6340 Baar,
Switzerland
T +41 (0) 41 768 6111

Emerson Automation Solutions
Emerson FZE P.O Box 17033,
Jebel Ali Free Zone - South 2
Dubai, United Arab Emirates
T +971 4 8118100

Emerson Automation Solutions
1 Pandan Crescent
Singapore 128461
T +65 6777 8211

Emerson Automation Solutions
(Latin America Regional Office)
1300 Concord Terrace, Suite 400
Sunrise, FL 33323
USA
T +1 954 846 5030

 [Emerson.com](https://www.emerson.com)

 [Facebook.com/EmersonAutomationSolutions](https://www.facebook.com/EmersonAutomationSolutions)

 [LinkedIn.com/company/Emerson-Automation-Solutions](https://www.linkedin.com/company/Emerson-Automation-Solutions)

 [Twitter.com/Emerson_News](https://twitter.com/Emerson_News)

Emerson Terms and Conditions of Sale are available upon request. The Emerson logo is a trademark and service mark of Emerson Electric Co. Rosemount is a mark of one of the Emerson family of companies. All other marks are the property of their respective owners.
© 2019 Emerson. All rights reserved.
00807-0800-4970_RevAA



EMERSON. CONSIDER IT SOLVED.™