

**Model EJA118W, EJA118N and
EJA118Y Diaphragm Sealed
Differential Pressure Transmitters
[Style: S2]**

IM 01C22H01-01E

vigilantplant.[®]

Model EJA118W, EJA118N and EJA118Y Diaphragm Sealed Differential Pressure Transmitters [Style: S2]

IM 01C22H01-01E 18th Edition

Contents

1.	Introduction.....	1-1
	■ Regarding This Manual.....	1-1
1.1	For Safe Use of Product	1-2
1.2	Warranty.....	1-3
1.3	ATEX Documentation	1-4
2.	Handling Cautions.....	2-1
2.1	Model and Specifications Check.....	2-1
2.2	Unpacking.....	2-1
2.3	Storage	2-1
2.4	Selecting the Installation Location	2-1
2.5	Pressure Connection.....	2-2
2.6	Waterproofing of Cable Conduit Connections	2-2
2.7	Restrictions on Use of Radio Transceiver	2-2
2.8	Insulation Resistance and Dielectric Strength Test.....	2-2
2.9	Installation of Explosion Protected Type	2-3
	2.9.1 FM Approval.....	2-4
	2.9.2 CSA Certification.....	2-5
	2.9.3 IECEx Certification.....	2-7
	2.9.4 ATEX Certification.....	2-9
	2.9.5 TIIS Certification	2-11
2.10	EMC Conformity Standards	2-12
2.11	PED (Pressure Equipment Directive)	2-12
2.12	Low Voltage Directive.....	2-12
3.	Component Names	3-1
4.	Installation.....	4-1
4.1	Precautions	4-1
4.2	Mounting the Diaphragm Seals.....	4-1
4.3	Transmitter Mounting	4-2
4.4	Affixing the Teflon Film	4-3
4.5	Rotating Transmitter Section.....	4-3
4.6	Changing the Direction of Integral Indicator	4-3

5.	Wiring	5-1
5.1	Wiring Precautions	5-1
5.2	Selecting the Wiring Materials.....	5-1
5.3	Connections of External Wiring to Terminal Box.....	5-1
5.3.1	Power Supply Wiring Connection	5-1
5.3.2	External Indicator Connection.....	5-2
5.3.3	BRAIN TERMINAL BT200 Connection	5-2
5.3.4	Check Meter Connection	5-2
5.4	Wiring	5-2
5.4.1	Loop Configuration	5-2
5.4.2	Wiring Installation.....	5-3
5.5	Grounding.....	5-4
5.6	Power Supply Voltage and Load Resistance	5-4
6.	Operation	6-1
6.1	Preparation for Starting Operation	6-1
6.2	Zero Point Adjustment	6-2
6.2.1	When you can obtain Low Range Value from actual measured value of 0% (0 kPa, atmospheric pressure);.....	6-2
6.2.2	When you cannot obtain Low Range Value from actual measured value of 0%;	6-2
6.3	Starting Operation	6-3
6.4	Shutting Down Operation	6-3
6.5	Setting the Range Using the Range-setting Switch.....	6-4
7.	BRAIN TERMINAL BT200 Operation	7-1
7.1	BT200 Operation Precautions	7-1
7.1.1	Connecting the BT200.....	7-1
7.1.2	Conditions of Communication Line.....	7-1
7.2	BT200 Operating Procedures	7-2
7.2.1	Key Layout and Screen Display.....	7-2
7.2.2	Operating Key Functions	7-2
7.2.3	Calling Up Menu Addresses Using the Operating Keys	7-4
7.3	Setting Parameters Using the BT200.....	7-5
7.3.1	Parameter Summary.....	7-5
7.3.2	Parameter Usage and Selection.....	7-7
7.3.3	Setting Parameters	7-9
(1)	Tag No. Setup	7-9
(2)	Calibration Range Setup.....	7-9
(3)	Damping Time Constant Setup	7-10

	(4) Output Mode and Integral Indicator Display Mode Setup	7-11
	(5) Output Signal Low Cut Mode Setup	7-11
	(6) Change Output Limits	7-11
	(7) Integral Indicator Scale Setup.....	7-12
	(8) Unit Setup for Displayed Temperature	7-13
	(9) Unit Setup for Displayed Static Pressure	7-14
	(10) Operation Mode Setup	7-14
	(11) Impulse Line Connection Orientation Setup	7-14
	(12) Output Status Display/Setup when a CPU Failure	7-14
	(13) Output Status Setup when a Hardware Error Occurs	7-15
	(14) Bi-directional Flow Measurement Setup	7-15
	(15) Range Change while Applying Actual Inputs	7-16
	(16) Zero Point Adjustment	7-17
	(17) Span Adjustment.....	7-18
	(18) Test Output Setup	7-19
	(19) Ambient Temperature Zero Shift Compensation	7-19
	(20) User Memo Fields.....	7-20
7.4	Displaying Data Using the BT200.....	7-21
	7.4.1 Displaying Measured Data.....	7-21
	7.4.2 Display Transmitter Model and Specifications.....	7-21
7.5	Self-Diagnostics.....	7-21
	7.5.1 Checking for Problems	7-21
	7.5.2 Errors and Countermeasures	7-23
8.	Maintenance.....	8-1
	8.1 Overview	8-1
	8.2 Calibration Instruments Selection	8-1
	8.3 Calibration	8-1
	8.4 Disassembly and Reassembly	8-3
	8.4.1 Replacing the Integral Indicator	8-3
	8.4.2 Replacing the CPU Assembly.....	8-4
	8.5 Troubleshooting.....	8-5
	8.5.1 Basic Troubleshooting	8-5
	8.5.2 Troubleshooting Flow Charts.....	8-5
9.	General Specifications	9-1
	9.1 Standard Specifications.....	9-1
	9.2 Model and Suffix Codes	9-4
	9.3 Optional Specifications.....	9-7
	9.4 Dimensions.....	9-10

Installation and Operating Precautions for TIS Inherently Safe Equipment	EX-A03E
.....	
Installation and Operating Precautions for TIS Flameproof Equipment	EX-B03E
.....	
Customer Maintenance Parts List	
DPharp EJA Series Transmitter Section	CMPL 01C22A01-02E
Models EJA118W, EJA118N and EJA118Y	
Diaphragm Sealed Differential Pressure Transmitter	
(Pressure-detector Section)	CMPL 01C22H01-01E
Revision Information	

1. Introduction

Thank you for purchasing the DPharp electronic pressure transmitter.

The DPharp Pressure Transmitters are precisely calibrated at the factory before shipment. To ensure correct and efficient use of the instrument, please read this manual thoroughly and fully understand how to operate the instrument before operating it.

■ Regarding This Manual

- This manual should be passed on to the end user.
- The contents of this manual are subject to change without prior notice.
- All rights reserved. No part of this manual may be reproduced in any form without Yokogawa's written permission.
- Yokogawa makes no warranty of any kind with regard to this manual, including, but not limited to, implied warranty of merchantability and fitness for a particular purpose.
- If any question arises or errors are found, or if any information is missing from this manual, please inform the nearest Yokogawa sales office.
- The specifications covered by this manual are limited to those for the standard type under the specified model number break-down and do not cover custom-made instruments.
- Please note that changes in the specifications, construction, or component parts of the instrument may not immediately be reflected in this manual at the time of change, provided that postponement of revisions will not cause difficulty to the user from a functional or performance standpoint.
- Yokogawa assumes no responsibilities for this product except as stated in the warranty.
- If the customer or any third party is harmed by the use of this product, Yokogawa assumes no responsibility for any such harm owing to any defects in the product which were not predictable, or for any indirect damages.



NOTE

For FOUNDATION Fieldbus™, PROFIBUS PA and HART protocol versions, please refer to IM 01C22T02-01E, IM 01C22T03-00E and IM 01C22T01-01E respectively, in addition to this manual.

- The following safety symbol marks are used in this manual:



WARNING

Indicates a potentially hazardous situation which, if not avoided, could result in death or serious injury.



CAUTION

Indicates a potentially hazardous situation which, if not avoided, may result in minor or moderate injury. It may also be used to alert against unsafe practices.



IMPORTANT

Indicates that operating the hardware or software in this manner may damage it or lead to system failure.



NOTE

Draws attention to information essential for understanding the operation and features.

--- Direct current

1.1 For Safe Use of Product

For the protection and safety of the operator and the instrument or the system including the instrument, please be sure to follow the instructions on safety described in this manual when handling this instrument. In case the instrument is handled in contradiction to these instructions, Yokogawa does not guarantee safety. Please give your attention to the followings.

(a) Installation

- The instrument must be installed by an expert engineer or a skilled personnel. The procedures described about INSTALLATION are not permitted for operators.
- In case of high process temperature, care should be taken not to burn yourself because the surface of body and case reaches a high temperature.
- The instrument installed in the process is under pressure. Never loosen the process connector bolts to avoid the dangerous spouting of process fluid.
- During draining condensate from the pressuredetector section, take appropriate care to avoid contact with the skin, eyes or body, or inhalation of vapors, if the accumulated process fluid may be toxic or otherwise harmful.
- When removing the instrument from hazardous processes, avoid contact with the fluid and the interior of the meter.
- All installation shall comply with local installation requirement and local electrical code.

(b) Wiring

- The instrument must be installed by an expert engineer or a skilled personnel. The procedures described about WIRING are not permitted for operators.
- Please confirm that voltages between the power supply and the instrument before connecting the power cables and that the cables are not powered before connecting.

(c) Operation

- Wait 10 min. after power is turned off, before opening the covers.

(d) Maintenance

- Please do not carry out except being written to a maintenance descriptions. When these procedures are needed, please contact nearest YOKOGAWA office.
- Care should be taken to prevent the build up of drift, dust or other material on the display glass and name plate. In case of its maintenance, soft and dry cloth is used.

(e) Explosion Protected Type Instrument

- Users of explosion proof instruments should refer first to section 2.9 (Installation of an Explosion Protected Instrument) of this manual.
- The use of this instrument is restricted to those who have received appropriate training in the device.
- Take care not to create sparks when accessing the instrument or peripheral devices in a hazardous location.

(f) Modification

- Yokogawa will not be liable for malfunctions or damage resulting from any modification made to this instrument by the customer.

1.2 Warranty

- The warranty shall cover the period noted on the quotation presented to the purchaser at the time of purchase. Problems occurred during the warranty period shall basically be repaired free of charge.
- In case of problems, the customer should contact the Yokogawa representative from which the instrument was purchased, or the nearest Yokogawa office.
- If a problem arises with this instrument, please inform us of the nature of the problem and the circumstances under which it developed, including the model specification and serial number. Any diagrams, data and other information you can include in your communication will also be helpful.
- Responsible party for repair cost for the problems shall be determined by Yokogawa based on our investigation.
- The Purchaser shall bear the responsibility for repair costs, even during the warranty period, if the malfunction is due to:
 - Improper and/or inadequate maintenance by the purchaser.
 - Failure or damage due to improper handling, use or storage which is out of design conditions.
 - Use of the product in question in a location not conforming to the standards specified by Yokogawa, or due to improper maintenance of the installation location.
 - Failure or damage due to modification or repair by any party except Yokogawa or an approved representative of Yokogawa.
 - Malfunction or damage from improper relocation of the product in question after delivery.
 - Reason of force majeure such as fires, earthquakes, storms/floods, thunder/lightening, or other natural disasters, or disturbances, riots, warfare, or radioactive contamination.

1.3 ATEX Documentation

This procedure is only applicable to the countries in European Union.

<p>GB All instruction manuals for ATEX Ex related products are available in English, German and French. Should you require Ex related instructions in your local language, you are to contact your nearest Yokogawa office or representative.</p>	<p>SK Všetky návody na obsluhu pre prístroje s ATEX Ex sú k dispozícii v jazyku anglickom, nemeckom a francúzskom. V prípade potreby návodu pre Ex-prístroje vo Vašom národnom jazyku, skontaktujte prosím miestnu kanceláriu firmy Yokogawa.</p>
<p>DK Alle brugervejledninger for produkter relateret til ATEX Ex er tilgængelige på engelsk, tysk og fransk. Skulle De ønske yderligere oplysninger om håndtering af Ex produkter på eget sprog, kan De rette henvendelse herom til den nærmeste Yokogawa afdeling eller forhandler.</p>	<p>CZ Všechny uživatelské příručky pro výrobky, na něž se vztahuje nevybušné schválení ATEX Ex, jsou dostupné v angličtině, němčině a francouzštině. Požadujete-li pokyny týkající se výrobků s nevybušným schválením ve vašem lokálním jazyku, kontaktujte prosím vaši nejbližší reprezentační kancelář Yokogawa.</p>
<p>I Tutti i manuali operativi di prodotti ATEX contrassegnati con Ex sono disponibili in inglese, tedesco e francese. Se si desidera ricevere i manuali operativi di prodotti Ex in lingua locale, mettersi in contatto con l'ufficio Yokogawa più vicino o con un rappresentante.</p>	<p>LT Visos gaminių ATEX Ex kategorijos Eksploatavimo instrukcijos teikiama anglų, vokiečių ir prancūzų kalbomis. Norėdami gauti prietaisų Ex dokumentaciją kitomis kalbomis susisieki su artimiausiu bendrovės "Yokogawa" biuru arba atstovu.</p>
<p>E Todos los manuales de instrucciones para los productos antiexplosivos de ATEX están disponibles en inglés, alemán y francés. Si desea solicitar las instrucciones de estos artículos antiexplosivos en su idioma local, deberá ponerse en contacto con la oficina o el representante de Yokogawa más cercano.</p>	<p>LV Visas ATEX Ex kategorijas izstrādājumu Lietošanas instrukcijas tiek piegādātas angļu, vācu un franču valodās. Ja vēlaties saņemt Ex ierīšu dokumentāciju citā valodā, Jums ir jāsazinās ar firmas Jokogava (Yokogawa) tuvāko ofisu vai pārstāvi.</p>
<p>NL Alle handleidingen voor producten die te maken hebben met ATEX explosiebeveiliging (Ex) zijn verkrijgbaar in het Engels, Duits en Frans. Neem, indien u aanwijzingen op het gebied van explosiebeveiliging nodig hebt in uw eigen taal, contact op met de dichtstbijzijnde vestiging van Yokogawa of met een vertegenwoordiger.</p>	<p>EST Kõik ATEX Ex tooteid kasutamisejuhendid on esitatud inglise, saksa ja prantsuse keeles. Ex seadmete muukeelse dokumentatsiooni saamiseks pöörduge lähima lokagava (Yokogawa) kontori või esindaja poole.</p>
<p>SF Kaikkien ATEX Ex -tyyppisten tuotteiden käyttöohjeet ovat saatavilla englannin-, saksan- ja ranskankielisinä. Mikäli tarvitsette Ex -tyyppisten tuotteiden ohjeita omalla paikallisella kielellänne, ottakaa yhteyttä lähimpään Yokogawa-toimistoon tai -edustajaan.</p>	<p>PL Wszystkie instrukcje obsługi dla urządzeń w wykonaniu przeciwwybuchowym Ex, zgodnych z wymaganiami ATEX, dostępne są w języku angielskim, niemieckim i francuskim. Jeżeli wymagana jest instrukcja obsługi w Państwa lokalnym języku, prosimy o kontakt z najbliższym biurem Yokogawy.</p>
<p>P Todos os manuais de instruções referentes aos produtos Ex da ATEX estão disponíveis em Inglês, Alemão e Francês. Se necessitar de instruções na sua língua relacionadas com produtos Ex, deverá entrar em contacto com a delegação mais próxima ou com um representante da Yokogawa.</p>	<p>SLO Vsi predpisi in navodila za ATEX Ex sorodni pridelki so pri roki v angleščini, nemščini ter francoščini. Če so Ex sorodna navodila potrebna v vašem tujejnem jeziku, kontaktirajte vaš najbližji Yokogawa office ili predstavnika.</p>
<p>F Tous les manuels d'instruction des produits ATEX Ex sont disponibles en langue anglaise, allemande et française. Si vous nécessitez des instructions relatives aux produits Ex dans votre langue, veuillez bien contacter votre représentant Yokogawa le plus proche.</p>	<p>H Az ATEX Ex műszerek gépkönyveit angol, német és francia nyelven adjuk ki. Amennyiben helyi nyelven kéri az Ex eszközök leírásait, kérjük keressék fel a legközelebbi Yokogawa irodát, vagy képviselőt.</p>
<p>D Alle Betriebsanleitungen für ATEX Ex bezogene Produkte stehen in den Sprachen Englisch, Deutsch und Französisch zur Verfügung. Sollten Sie die Betriebsanleitungen für Ex-Produkte in Ihrer Landessprache benötigen, setzen Sie sich bitte mit Ihrem örtlichen Yokogawa-Vertreter in Verbindung.</p>	<p>BG Всички упътвания за продукти от серията ATEX Ex се предлагат на английски, немски и френски език. Ако се нуждаете от упътвания за продукти от серията Ex на родния ви език, се свържете с най-близкия офис или представителство на фирма Yokogawa.</p>
<p>S Alla instruktionsböcker för ATEX Ex (explosionssäkra) produkter är tillgängliga på engelska, tyska och franska. Om Ni behöver instruktioner för dessa explosionssäkra produkter på annat språk, skall Ni kontakta närmaste Yokogawakontor eller representant.</p>	<p>RO Toate manualele de instructiuni pentru produsele ATEX Ex sunt in limba engleza, germana si franceza. In cazul in care doriti instructiunile in limba locala, trebuie sa contactati cel mai apropiat birou sau reprezentant Yokogawa.</p>
<p>GR Όλα τα εγχειρίδια λειτουργίας των προϊόντων με ATEX Ex διατίθενται στα Αγγλικά, Γερμανικά και Γαλλικά. Σε περίπτωση που χρειάζεστε οδηγίες σχετικά με Ex στην τοπική γλώσσα παρακαλούμε επικοινωνήστε με το πλησιέστερο γραφείο της Yokogawa ή αντιπρόσωπο της.</p>	<p>M Il-manwali kollha ta' l-istruzzjonijiet għal prodotti marbuta ma' ATEX Ex huma disponibbli bi-Ingliż, bi-Ġermaniż u bi-Franċiż. Jekk tkun teħtieġ struzzjonijiet marbuta ma' Ex fil-lingwa lokali tiegħek, għandek tikkuntattja lill-eqreb rappreżentant jew uffċju ta' Yokogawa.</p>

2. Handling Cautions

This chapter describes important cautions regarding how to handle the transmitter. Read carefully before using the transmitter.

The EJA Series pressure transmitters are thoroughly tested at the factory before shipment. When the transmitter is delivered, visually check them to make sure that no damage occurred during shipment.

Also check that all transmitter mounting hardware shown in Figure 2.1 is included. If the transmitter was ordered without the mounting bracket, the transmitter mounting hardware is not included. After checking the transmitter, repack it in the way it was delivered until installation.

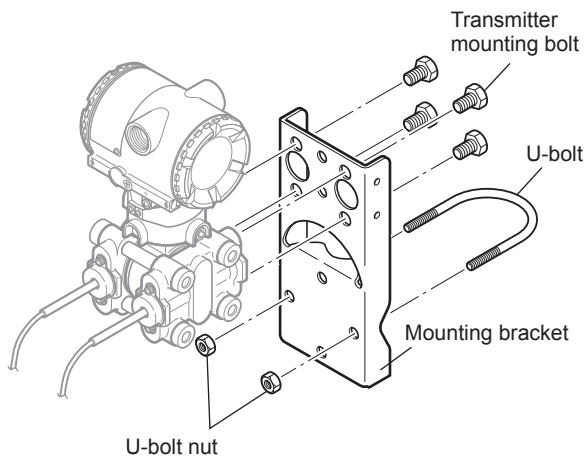

F0201.ai

Figure 2.1 Transmitter Mounting Hardware

2.1 Model and Specifications Check

The model name and specifications are indicated on the name plate attached to the case. If the reverse operating mode was ordered (reverse signal), 'REVERSE' will be inscribed in field *1; if square root display mode was ordered, 'SQRT' is inscribed in field *2; if square root output mode was ordered, 'SQRT' is inscribed in field *3.

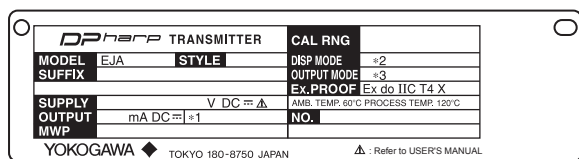

F0202.ai

Figure 2.2 Name Plate Example of TIIS Flameproof Type

2.2 Unpacking

When moving the transmitter to the installation site, keep it in its original packaging. Then, unpack the transmitter there to avoid damage on the way.

2.3 Storage

The following precautions must be observed when storing the instrument, especially for a long period.

- (a) Select a storage area which meets the following conditions:
 - It is not exposed to rain or water.
 - It suffers minimum vibration and shock.
 - It has an ambient temperature and relative humidity within the following ranges.

Ambient temperature:

- 40 to 85°C without integral indicator
- 30 to 80°C with integral indicator

Relative humidity:

5% to 100% R.H. (at 40°C)

Preferred temperature and humidity:

approx. 25°C and 65% R.H.

- (b) When storing the transmitter, repack it as nearly as possible to the way it was packed when delivered from the factory.
- (c) If storing a transmitter that has been used, thoroughly clean the diaphragm surface of the diaphragm seal (pressure-detector section), so that no measured fluid remains on them. Also make sure before storing that the pressure-detector and transmitter assemblies are securely mounted.

2.4 Selecting the Installation Location

The transmitter is designed to withstand severe environmental conditions. However, to ensure stable and accurate operation for years, observe the following precautions when selecting an installation location.

- (a) Ambient Temperature

Avoid locations subject to wide temperature variations or a significant temperature gradient. If the location is exposed to radiant heat from plant equipments, provide adequate thermal insulation and/or ventilation.

- (b) Ambient Atmosphere
Avoid installing the transmitter in a corrosive atmosphere. If the transmitter must be installed in a corrosive atmosphere, there must be adequate ventilation as well as measures to prevent intrusion or stagnation of rain water in conduits.
- (c) Shock and Vibration
Select an installation site suffering minimum shock and vibration (although the transmitter is designed to be relatively resistant to shock and vibration).
- (d) Installation of Explosion-protected Transmitters
Explosion-protected transmitters can be installed in hazardous areas according to the types of gases for which they are certified. See Subsection 2.9 "Installation of Explosion Protected Type Transmitters."

2.5 Pressure Connection



WARNING

- Instrument installed in the process is under pressure. Never loosen or tighten the flange bolts to avoid the dangerous spouting of process fluid.
- Since the accumulated process fluid may be toxic or otherwise harmful, take appropriate care to avoid contact with the skin, eyes or body, or inhalation of vapors even after dismantling the instrument from process line for maintenance.

The following precautions must be observed in order to safely operate the transmitter under pressure.

- (a) Never apply a pressure higher than the specified maximum working pressure.
- (b) Never loosen or tighten the bolts securing the diaphragm seal flanges when the assembly is under pressure. Do it after releasing the process pressure if required.

2.6 Waterproofing of Cable Conduit Connections

Apply a non-hardening sealant to the threads to waterproof the transmitter cable conduit connections. (See Figure 5.7, 5.8 and 5.10.)

2.7 Restrictions on Use of Radio Transceiver



IMPORTANT

Although the transmitter has been designed to resist high frequency electrical noise, if a radio transceiver is used near the transmitter or its external wiring, the transmitter may be affected by high frequency noise pickup. To test for such effects, bring the transceiver in use slowly from a distance of several meters from the transmitter, and observe the measurement loop for noise effects. Thereafter, always use the transceiver outside the area affected by noise.

2.8 Insulation Resistance and Dielectric Strength Test

Since the transmitter has undergone insulation resistance and dielectric strength tests at the factory before shipment, normally these tests are not required.

However, if required, observe the following precautions in the test procedures.

- (a) Do not perform such tests more frequently than is absolutely necessary. Even test voltages that do not cause visible damage to the insulation may degrade the insulation and reduce safety margins.
- (b) Never apply a voltage exceeding 500 V DC (100 V DC with an internal lightning protector) for the insulation resistance test, nor a voltage exceeding 500 V AC (100 V AC with an internal lightning protector) for the dielectric strength test.
- (c) Before conducting these tests, disconnect all signal lines from the transmitter terminals. Perform the tests in the following procedure:

• Insulation Resistance Test

- 1) Short-circuit the + and – SUPPLY terminals in the terminal box.
- 2) Turn OFF the insulation tester. Then connect the insulation tester plus (+) lead wire to the shorted SUPPLY terminals and the minus (–) leadwire to the grounding terminal.
- 3) Turn ON the insulation tester power and measure the insulation resistance. The voltage should be applied short as possible to verify that the insulation resistance is at least 20 MΩ.
- 4) After completing the test and being very careful not to touch exposed conductors disconnect the insulation tester and connect a 100 kΩ resistor between the grounding terminal and the shortcircuiting SUPPLY terminals. Leave this resistor connected at least one second to discharge any static potential. Do not touch the terminals while it is discharging.

• Dielectric Strength Test

- 1) Short-circuit the + and – SUPPLY terminals in the terminal box.
- 2) Turn OFF the dielectric strength tester. Then connect the tester between the shorted SUPPLY terminals and the grounding terminal. Be sure to connect the grounding lead of the dielectric strength tester to the ground terminal.
- 3) Set the current limit on the dielectric strength tester to 10 mA, then turn ON the power and gradually increase the test voltage from '0' to the specified voltage.
- 4) When the specified voltage is reached, hold it for one minute.
- 5) After completing this test, slowly decrease the voltage to avoid any voltage surges.

2.9 Installation of Explosion Protected Type

In this section, further requirements and differences and for explosionproof type instrument are described. For explosionproof type instrument, the description in this chapter is prior to other description in this users manual.

For the intrinsically safe equipment and explosionproof equipment, in case the instrument is not restored to its original condition after any repair or modification undertaken by the customer, intrinsically safe construction or explosionproof construction is damaged and may cause dangerous condition. Please contact Yokogawa for any repair or modification required to the instrument.

**NOTE**

For FOUNDATION Fieldbus and PROFIBUS PA explosion protected type, please refer to IM 01C22T02-01E and IM 01C22T03-00E respectively.

**CAUTION**

This instrument is tested and certified as intrinsically safe type or explosionproof type. Please note that the construction of the instrument, installation, external wiring, maintenance or repair is strictly restricted, and non-observance or negligence of this restriction would result in dangerous condition.

**WARNING**

To preserve the safety of explosionproof equipment requires great care during mounting, wiring, and piping. Safety requirements also place restrictions on maintenance and repair activities. Please read the following sections very carefully.

2.9.1 FM Approval

a. FM Intrinsically Safe Type

Caution for FM intrinsically safe type. (Following contents refer “DOC. No. IFM012-A12 P.1 and 2.”)

Note 1. Model EJA Series pressure transmitters with optional code /FS1 are applicable for use in hazardous locations.

- Applicable Standard: FM3600, FM3610, FM3611, FM3810, ANSI/NEMA250
- Intrinsically Safe for Class I, Division 1, Groups A, B, C & D. Class II, Division 1, Groups E, F & G and Class III, Division 1 Hazardous Locations.
- Nonincendive for Class I, Division 2, Groups A, B, C & D. Class II, Division 2, Groups E, F & G and Class III, Division 1 Hazardous Locations.
- Outdoor hazardous locations, NEMA 4X.
- Temperature Class: T4
- Ambient temperature: -40 to 60°C

Note 2. Entity Parameters

- Intrinsically Safe Apparatus Parameters [Groups A, B, C, D, E, F and G]

$V_{max} = 30\text{ V}$ $C_i = 22.5\text{ nF}$
 $I_{max} = 165\text{ mA}$ $L_i = 730\text{ }\mu\text{H}$
 $P_{max} = 0.9\text{ W}$

- * Associated Apparatus Parameters (FM approved barriers)

$V_{oc} \leq 30\text{ V}$ $C_a > 22.5\text{ nF}$
 $I_{sc} \leq 165\text{ mA}$ $L_a > 730\text{ }\mu\text{H}$
 $P_{max} \leq 0.9\text{ W}$

- Intrinsically Safe Apparatus Parameters [Groups C, D, E, F and G]

$V_{max} = 30\text{ V}$ $C_i = 22.5\text{ nF}$
 $I_{max} = 225\text{ mA}$ $L_i = 730\text{ }\mu\text{H}$
 $P_{max} = 0.9\text{ W}$

- * Associated Apparatus Parameters (FM approved barriers)

$V_{oc} \leq 30\text{ V}$ $C_a > 22.5\text{ nF}$
 $I_{sc} \leq 225\text{ mA}$ $L_a > 730\text{ }\mu\text{H}$
 $P_{max} \leq 0.9\text{ W}$

- Entity Installation Requirements
 $V_{max} \geq V_{oc}$ or V_t , $I_{max} \geq I_{sc}$ or I_t ,
 P_{max} (IS Apparatus) $\geq P_{max}$ (Barrier)
 $C_a \geq C_i + C_{cable}$, $L_a \geq L_i + L_{cable}$

Note 3. Installation

- Barrier must be installed in an enclosure that meets the requirements of ANSI/ISA S82.01.
- Control equipment connected to barrier must not use or generate more than 250 V rms or V dc.
- Installation should be in accordance with ANSI/ISA RP12.6 “Installation of Intrinsically Safe Systems for Hazardous (Classified) Locations” and the National Electric Code (ANSI/NFPA 70).
- The configuration of associated apparatus must be FMRC Approved.
- Dust-tight conduit seal must be used when installed in a Class II, III, Group E, F and G environments.
- Associated apparatus manufacturer’s installation drawing must be followed when installing this apparatus.
- The maximum power delivered from the barrier must not exceed 0.9 W.
- Note a warning label worded “SUBSTITUTION OF COMPONENTS MAY IMPAIR INTRINSIC SAFETY,” and “INSTALL IN ACCORDANCE WITH DOC. No. IFM012-A12 P.1 and 2.”

Note 4. Maintenance and Repair

- The instrument modification or parts replacement by other than authorized representative of Yokogawa Electric Corporation is prohibited and will void Factory Mutual Intrinsically safe and Nonincendive Approval.

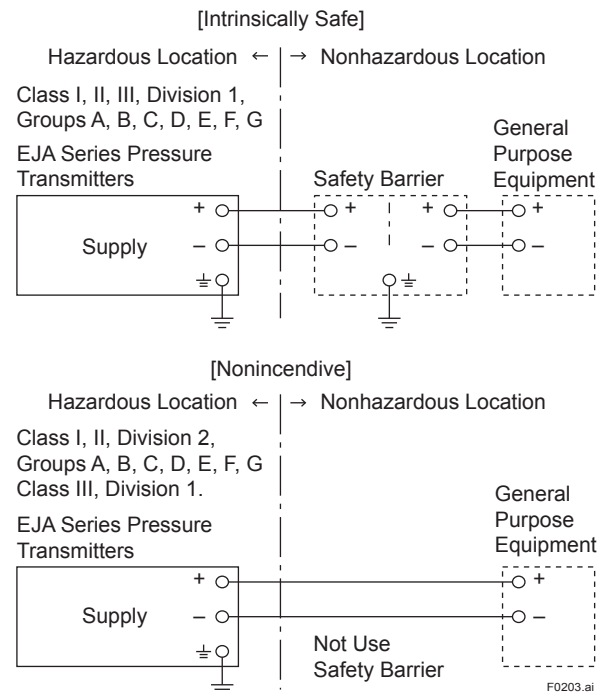

F0203.ai

b. FM Explosionproof Type

Caution for FM explosionproof type.

Note 1. Model EJA Series differential, gauge, and absolute pressure transmitters with optional code /FF1 are applicable for use in hazardous locations.

- Applicable Standard: FM3600, FM3615, FM3810, ANSI/NEMA250
- Explosionproof for Class I, Division 1, Groups B, C and D.
- Dust-ignitionproof for Class II/III, Division 1, Groups E, F and G.
- Outdoor hazardous locations, NEMA 4X.
- Temperature Class: T6
- Ambient Temperature: –40 to 60°C
- Supply Voltage: 42 V dc max.
- Output signal: 4 to 20 mA

Note 2. Wiring

- All wiring shall comply with National Electrical Code ANSI/NEPA70 and Local Electrical Codes.
- When installed in Division 1, “FACTORY SEALED, CONDUIT SEAL NOT REQUIRED.”

Note 3. Operation

- Keep the “CAUTION” nameplate attached to the transmitter.
CAUTION: OPEN CIRCUIT BEFORE REMOVING COVER. FACTORY SEALED, CONDUIT SEAL NOT REQUIRED. INSTALL IN ACCORDANCE WITH THE INSTRUCTION MANUAL IM 1C22.
- Take care not to generate mechanical sparking when accessing to the instrument and peripheral devices in a hazardous location.

Note 4. Maintenance and Repair

- The instrument modification or parts replacement by other than authorized representative of Yokogawa Electric Corporation is prohibited and will void Factory Mutual Explosionproof Approval.

c. FM Intrinsically Safe Type/FM Explosionproof Type

Model EJA Series pressure transmitters with optional code /FU1 can be selected the type of protection (FM Intrinsically Safe or FM Explosionproof) for use in hazardous locations.

Note 1. For the installation of this transmitter, once a particular type of protection is selected, any other type of protection cannot be used. The installation must be in accordance with the description about the type of protection in this instruction manual.

Note 2. In order to avoid confusion, unnecessary marking is crossed out on the label other than the selected type of protection when the transmitter is installed.

2.9.2 CSA Certification**a. CSA Intrinsically Safe Type**

Caution for CSA Intrinsically safe type. (Following contents refer to “DOC No. ICS003-A12 P.1-1 and P.1-2.”)

Note 1. Model EJA Series differential, gauge, and absolute pressure transmitters with optional code /CS1 are applicable for use in hazardous locations

Certificate: 1053843

- Applicable Standard: C22.2 No.0, No.0.4, No.25, No.30, No.94, No.142, No.157, No.213
- Intrinsically Safe for Class I, Division 1, Groups A, B, C & D. Class II, Division 1, Groups E, F & G and Class III, Division 1 Hazardous Locations.
- Nonincendive for Class I, Division 2, Groups A, B, C & D, Class II, Division 2, Groups F & G, and Class III, Hazardous Locations. (not use Safety Barrier)
- Encl. “Type 4X”
- Temperature Class: T4
- Ambient temperature: –40* to 60°C
* –15°C when /HE is specified.
- Process Temperature: 120°C max.

Note 2. Entity Parameters

- Intrinsically safe ratings are as follows:
 Maximum Input Voltage (Vmax) = 30 V
 Maximum Input Current (Imax) = 165 mA
 Maximum Input Power (Pmax) = 0.9 W
 Maximum Internal Capacitance (Ci) = 22.5nF
 Maximum Internal Inductance (Li) = 730 μH
- * Associated apparatus (CSA certified barriers)
 Maximum output voltage (Voc) ≤ 30 V
 Maximum output current (Isc) ≤ 165 mA
 Maximum output power (Pmax) ≤ 0.9 W

Note 3. Installation

- All wiring shall comply with Canadian Electrical Code Part I and Local Electrical Codes.
- The instrument modification or parts replacement by other than authorized representative of Yokogawa Electric Corporation and Yokogawa Corporation of America is prohibited and will void Canadian Standards Intrinsically safe and nonincendive Certification.

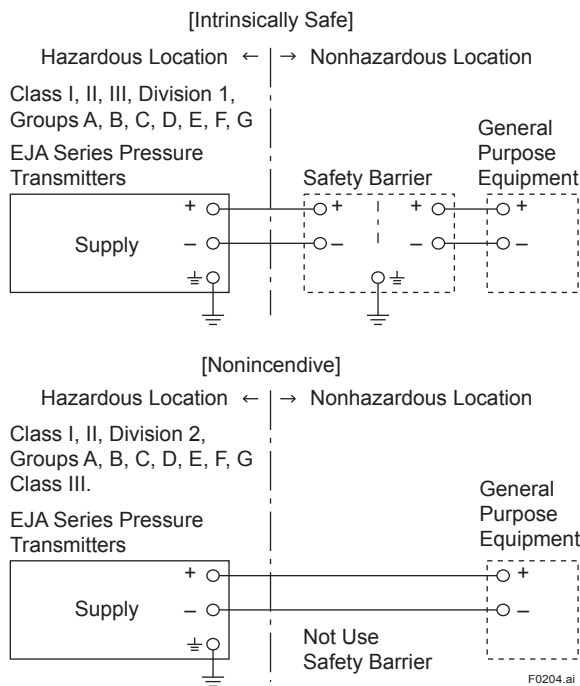

b. CSA Explosionproof Type

Caution for CSA explosionproof type.

Note 1. Model EJA Series differential, gauge, and absolute pressure transmitters with optional code /CF1 are applicable for use in hazardous locations:

Certificate: 1089598

- Applicable Standard: C22.2 No.0, No.0.4, No.25, No.30, No.94, No.142
- Explosionproof for Class I, Division 1, Groups B, C and D.
- Dust-ignitionproof for Class II/III, Division 1, Groups E, F and G.
- Encl "Type 4X"
- Temperature Class: T6, T5, and T4
- Process Temperature: 85°C (T6), 100°C (T5), and 120°C (T4)
- Ambient Temperature: -40* to 80°C
 * -15°C when /HE is specified.
- Supply Voltage: 42 V dc max.
- Output Signal: 4 to 20 mA

Note 2. Wiring

- All wiring shall comply with Canadian Electrical Code Part I and Local Electrical Codes.
- In hazardous location, wiring shall be in conduit as shown in the figure.
CAUTION: SEAL ALL CONDUITS WITHIN 50 cm OF THE ENCLOSURE.
UN SCELLEMENT DOIT ÊTRE INSTALLÉ À MOINS DE 50 cm DU BÂTIER.
- When installed in Division 2, "SEALS NOT REQUIRED."

Note 3. Operation

- Keep the "CAUTION" label attached to the transmitter.
CAUTION: OPEN CIRCUIT BEFORE REMOVING COVER.
OUVRIR LE CIRCUIT AVANT D'NLEVER LE COUVERCLE.
- Take care not to generate mechanical sparking when accessing to the instrument and peripheral devices in a hazardous location.

Note 4. Maintenance and Repair

- The instrument modification or parts replacement by other than authorized representative of Yokogawa Electric Corporation and Yokogawa Corporation of America is prohibited and will void Canadian Standards Explosionproof Certification.

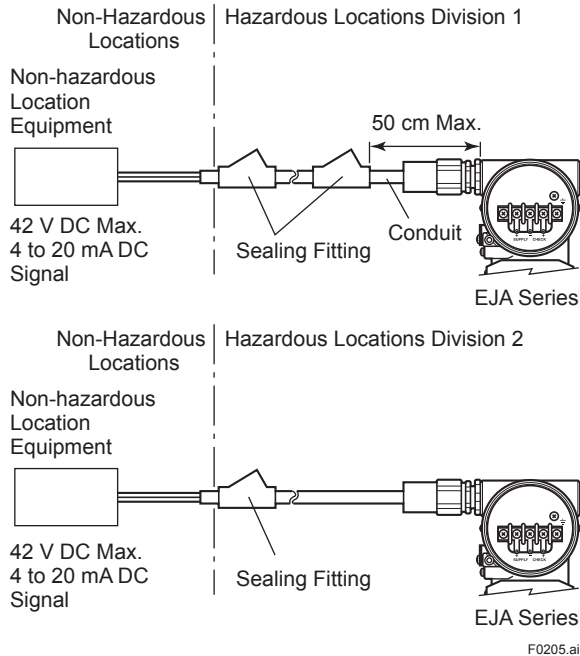

c. CSA Intrinsically Safe Type/CSA Explosionproof Type

Model EJA Series pressure transmitters with optional code /CU1 can be selected the type of protection (CSA Intrinsically Safe or CSA Explosionproof) for use in hazardous locations.

Note 1. For the installation of this transmitter, once a particular type of protection is selected, any other type of protection cannot be used. The installation must be in accordance with the description about the type of protection in this instruction manual.

Note 2. In order to avoid confusion, unnecessary marking is crossed out on the label other than the selected type of protection when the transmitter is installed.

2.9.3 IECEx Certification

Model EJA Series differential, gauge, and absolute pressure transmitters with optional code /SU2 can be selected the type of protection (IECEx Intrinsically Safe/type n or flameproof) for use in hazardous locations.

Note 1. For the installation of this transmitter, once a particular type of protection is selected, any other type of protection cannot be used. The installation must be in accordance with the description about the type of protection in this instruction manual.

Note 2. In order to avoid confusion, unnecessary marking is crossed out on the label other than the selected type of protection when the transmitter is installed.

a. IECEx Intrinsically Safe Type / type n

Caution for IECEx Intrinsically safe and type n.

Note 1. Model EJA Series differential, gauge, and absolute pressure transmitters with optional code /SU2 are applicable for use in hazardous locations.

- No. IECEx KEM 06.0007X
- Applicable Standard: IEC 60079-0:2004, IEC 60079-11:1999, IEC 60079-15:2005, IEC 60079-26:2004
- Type of Protection and Marking Code: Ex ia IIC T4, Ex nL IIC T4
- Ambient Temperature : -40 to 60°C
- Max. Process Temp.: 120°C
- Enclosure: IP67

Note 2. Entity Parameters

- Intrinsically safe ratings are as follows:
 - Maximum Input Voltage (Ui) = 30 V
 - Maximum Input Current (Ii) = 165 mA
 - Maximum Input Power (Pi) = 0.9 W
 - Maximum Internal Capacitance (Ci) = 22.5nF
 - Maximum Internal Inductance (Li) = 730 μH
- Type “n” ratings are as follows:
 - Maximum Input Voltage (Ui) = 30 V
 - Maximum Internal Capacitance (Ci) = 22.5nF
 - Maximum Internal Inductance (Li) = 730 μH
- Installation Requirements
 - $U_o \leq U_i, I_o \leq I_i, P_o \leq P_i,$
 - $C_o \geq C_i + C_{cable}, L_o \geq L_i + L_{cable}$
 - $U_o, I_o, P_o, C_o,$ and L_o are parameters of barrier.

Note 3. Installation

- In any safety barrier used output current must be limited by a resistor 'R' such that $I_o = U_o/R$.
- The safety barrier must be IECEx certified.
- Input voltage of the safety barrier must be less than 250 Vrms/Vdc.
- The instrument modification or parts replacement by other than authorized representative of Yokogawa Electric Corporation will void IECEx Intrinsically safe and type n certification.
- The cable entry devices and blanking elements for type n shall be of a certified type providing a level of ingress protection of at least IP54, suitable for the conditions of use and correctly installed.
- Electrical Connection:
The type of electrical connection is stamped near the electrical connection port according to the following marking.

Screw Size	Marking
ISO M20 × 1.5 female	△ M
ANSI 1/2 NPT female	△ A

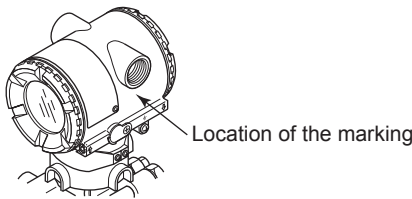

F0206.ai

Note 4. Operation

- **WARNING:**
WHEN AMBIENT TEMPERATURE $\geq 55^\circ\text{C}$,
USE THE HEAT-RESISTING CABLES $\geq 90^\circ\text{C}$.

Note 5. Special Conditions for Safe Use

- **WARNING:**
IN THE CASE WHERE THE ENCLOSURE OF THE PRESSURE TRANSMITTER IS MADE OF ALUMINUM, IF IT IS MOUNTED IN AN AREA WHERE THE USE OF ZONE 0 IS REQUIRED, IT MUST BE INSTALLED SUCH, THAT, EVEN IN THE EVENT OF RARE INCIDENTS, IGNITION SOURCES DUE TO IMPACT AND FRICTION SPARKS ARE EXCLUDED.

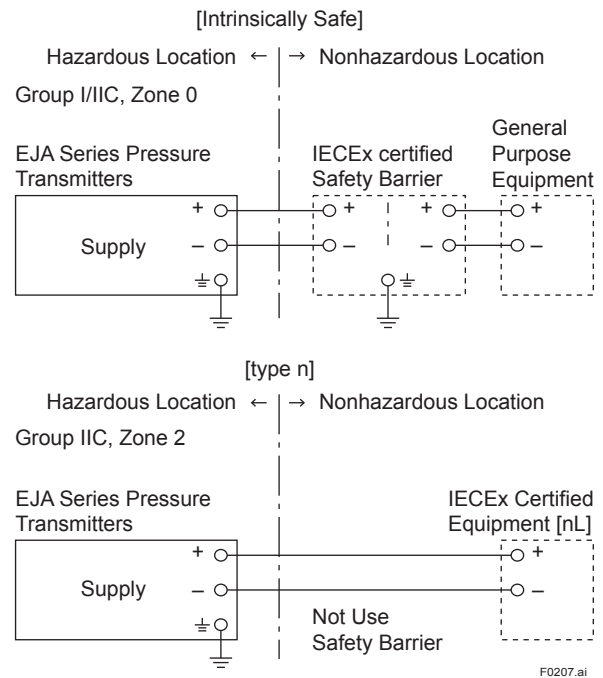

b. IECEx Flameproof Type

Caution for IECEx flameproof type.

Note 1. Model EJA Series differential, gauge, and absolute pressure transmitters with optional code /SU2 are applicable for use in hazardous locations:

- No. IECEx KEM 06.0005
- Applicable Standard: IEC60079-0:2004, IEC60079-1:2003
- Type of Protection and Marking Code: Ex d IIC T6...T4
- Enclosure: IP67
- Maximum Process Temperature: 120°C (T4), 100°C (T5), 85°C (T6)
- Ambient Temperature: -40 to 75°C (T4), -40 to 80°C (T5), -40 to 75°C (T6)
- Supply Voltage: 42 V dc max.
- Output Signal: 4 to 20 mA dc

Note 2. Wiring

- In hazardous locations, the cable entry devices shall be of a certified flameproof type, suitable for the conditions of use and correctly installed.
- Unused apertures shall be closed with suitable flameproof certified blanking elements. (The plug attached is certificated as the flame proof IP67 as a part of this apparatus.)
- In case of ANSI 1/2 NPT plug, ANSI hexagonal wrench should be applied to screw in.

Note 3. Operation

- WARNING:
AFTER DE-ENERGIZING, DELAY 10 MINUTES BEFORE OPENING.
- WARNING:
WHEN AMBIENT TEMPERATURE $\geq 70^{\circ}\text{C}$, USE THE HEAT-RESISTING CABLES $\geq 90^{\circ}\text{C}$.
- Take care not to generate mechanical sparking when accessing to the instrument and peripheral devices in a hazardous location.

Note 4. Maintenance and Repair

- The instrument modification or parts replacement by other than authorized representative of Yokogawa Electric Corporation is prohibited and will void IECEx Certification.

2.9.4 ATEX Certification

(1) Technical Data

a. ATEX Intrinsically Safe Type

Caution for ATEX Intrinsically safe type.

Note 1. Model EJA Series differential, gauge, and absolute pressure transmitters with optional code /KS2 for potentially explosive atmospheres:

- No. KEMA 02ATEX1030 X
- Applicable Standard: EN 50014:1997, EN 50020:1994, EN 50284:1999
- Type of Protection and Marking code: EEx ia IIC T4
- Temperature Class: T4
- Enclosure: IP67
- Process Temperature: 120°C max.
- Ambient Temperature: -40 to 60°C

Note 2. Electrical Data

- In type of explosion protection intrinsic safety EEx ia IIC only for connection to a certified intrinsically safe circuit with following maximum values:
 $U_i = 30\text{ V}$
 $I_i = 165\text{ mA}$
 $P_i = 0.9\text{ W}$
 Effective internal capacitance; $C_i = 22.5\text{ nF}$
 Effective internal inductance; $L_i = 730\text{ }\mu\text{H}$

Note 3. Installation

- All wiring shall comply with local installation requirements. (Refer to the installation diagram)

Note 4. Maintenance and Repair

- The instrument modification or parts replacement by other than authorized representative of Yokogawa Electric Corporation is prohibited and will void KEMA Intrinsically safe Certification.

Note 5. Special Conditions for Safe Use

- In the case where the enclosure of the Pressure Transmitter is made of aluminium, if it is mounted in an area where the use of category 1 G apparatus is required, it must be installed such, that, even in the event of rare incidents, ignition sources due to impact and friction sparks are excluded.

[Installation Diagram]

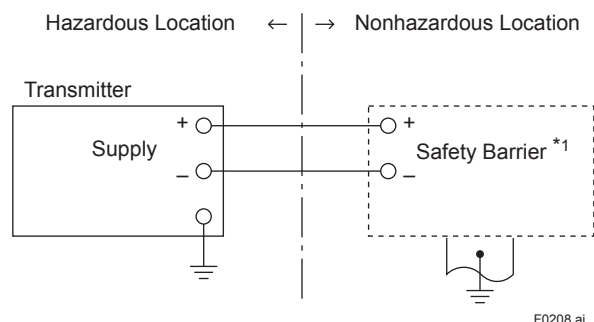

*1: In any safety barriers used the output current must be limited by a resistor "R" such that $I_{\text{maxout}} - U_z/R$.

b. ATEX Flameproof Type

Caution for ATEX flameproof type.

Note 1. Model EJA Series differential, gauge, and absolute pressure transmitters with optional code /KF21 for potentially explosive atmospheres:

- No. KEMA 02ATEX2148
- Applicable Standard: EN 60079-0:2006, EN 60079-1:2004
- Type of Protection and Marking Code: Ex d IIC T6...T4
- Temperature Class: T6, T5, and T4
- Enclosure: IP67
- Maximum Process Temperature: 85°C (T6), 100°C (T5), and 120°C (T4)
- Ambient Temperature: T4 and T6; -40° to 75°C , T5; -40° to 80°C
 -15°C when /HE is specified.

Note 2. Electrical Data

- Supply voltage: 42 V dc max.
- Output signal: 4 to 20 mA

Note 3. Installation

- All wiring shall comply with local installation requirement.
- The cable entry devices shall be of a certified flameproof type, suitable for the conditions of use.

Note 4. Operation

- Keep the “CAUTION” label to the transmitter. CAUTION: AFTER DE-ENERGIZING, DELAY 10 MINUTES BEFORE OPENING. WHEN THE AMBIENT TEMP. ≥ 70°C, USE HEAT-RESISTING CABLES ≥ 90°C.
- Take care not to generate mechanical sparking when accessing to the instrument and peripheral devices in a hazardous location.

Note 5. Maintenance and Repair

- The instrument modification or parts replacement by other than authorized representative of Yokogawa Electric Corporation is prohibited and will void KEMA Flameproof Certification.

(2) Electrical Connection

The type of electrical connection is stamped near the electrical connection port according to the following marking.

Screw Size	Marking
ISO M20 × 1.5 female	△ M
ANSI 1/2 NPT female	△ A

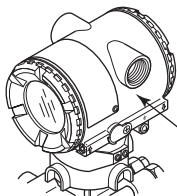

Location of the marking

F0206.ai

(3) Installation



WARNING

- All wiring shall comply with local installation requirement and local electrical code.
- There is no need of the conduit seal for both of Division 1 and Division 2 hazardous locations because this product is sealed at factory.
- In case of ANSI 1/2 NPT plug, ANSI hexagonal wrench should be applied to screw in.

(4) Operation



WARNING

- OPEN CIRCUIT BEFORE REMOVING COVER. INSTALL IN ACCORDANCE WITH THIS USER'S MANUAL
- Take care not to generate mechanical sparking when access to the instrument and peripheral devices in hazardous locations.

(5) Maintenance and Repair



WARNING

The instrument modification or parts replacement by other than authorized Representative of Yokogawa Electric Corporation is prohibited and will void the certification.

(6) Name Plate

- Name plate

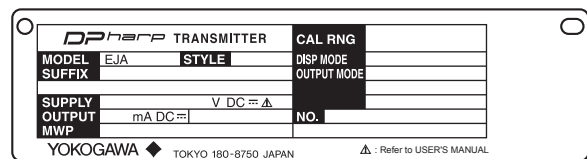

- Tag plate for flameproof type



- Tag plate for intrinsically safe type



F0210.ai

MODEL: Specified model code.
 STYLE: Style code.
 SUFFIX: Specified suffix code.
 SUPPLY: Supply voltage.
 OUTPUT: Output signal.
 MWP: Maximum working pressure.
 CAL RNG: Specified calibration range.
 DISP MODE: Specified display mode.
 OUTPUT MODE: Specified output mode.
 NO.: Serial number and year of production*1.
 TOKYO 180-8750 JAPAN:
 The manufacturer name and the address*2.

*1: The third figure from the last shows the last one figure of the year of production. For example, the production year of the product engraved in "NO." column on the name plate as follows is 2001.

12A819857 132
 ↑
The year 2001

*2: "180-8750" is a zip code which represents the following address.

2-9-32 Nakacho, Musashino-shi, Tokyo Japan

2.9.5 TIIS Certification

a. TIIS Flameproof Type

The model EJA Series pressure transmitter with optional code /JF3, which has obtained certification according to technical criteria for explosion-protected construction of electric machinery and equipment (Standards Notification No. 556 from the Japanese Ministry of Labor) conforming to IEC standards, is designed for hazardous areas where inflammable gases or vapors may be present. (This allows installation in Division 1 and 2 areas) To preserve the safety of flameproof equipment requires great care during mounting, wiring, and piping. Safety requirements also place restrictions on maintenance and repair activities. Users absolutely must read "Installation and Operating Precautions for TIIS Flameproof Equipment" at the end of this manual.



CAUTION

(For TIIS flameproof type without integral indicator)

When the fill fluid near the sensor part moves from within, the instrument outputs a failure signal either high or low of the specific signal. In that case, generate the alarm to identify that the failure signal is output since the event may invalidate the flameproof approval. If the optional integral indicator is equipped, the indicator identifies the alarm on its display. Therefore, no other alarm generation is necessary.

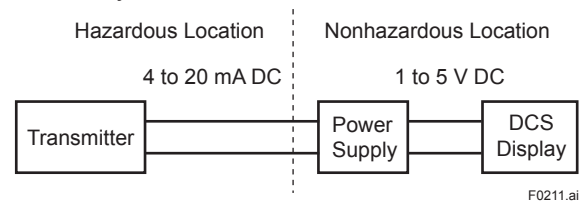

Figure 2.3 Example of using DCS (Distributed Control System)

b. TIIS Intrinsically Safe Type

The model EJA Series pressure transmitter with optional code /JS3, which has obtained certification according to technical criteria for explosionprotected construction of electric machinery and equipment (Standards Notification No.556 from the Japanese Ministry of Labor) conforming to IEC standards, is designed for hazardous areas where explosive or inflammable gases or vapors may be present. (This allows installation in Division 0, 1 and 2 areas)

To preserve the safety of flameproof equipment requires great care during mounting, wiring, and piping. Safety requirements also place restrictions on maintenance and repair activities. Users absolutely must read "Installation and Operating Precautions for TIIS Intrinsically Safe Equipment" at the end of this manual.

CAUTION

For using a safety-barrier with a pressure transmitter, the safety-barrier must be certified as a safety-barrier itself.

A safety-barrier must be used under the following condition.

- (1) Condition of the current and voltage limits
 - Maximum output voltage (U_o) ≤ 28 V
 - Maximum output current (I_o) ≤ 94.3 mA
 - Maximum output power (P_o) ≤ 0.66 W
- (2) Category and Group
 - Category ia
 - Group IIC
- (3) Relations between a maximum allowed inductance and a field wiring inductance, between a maximum allowed capacitance and a field wiring capacitance.

$$L_o \geq L_i + L_w$$

$$C_o \geq C_i + C_w$$

($L_i = 730\mu\text{H}$, $C_i = 11\text{nF}$)

L_o = Maximum external inductance
 L_i = Maximum internal inductance
 L_w = Field wiring inductance
 C_o = Maximum external capacitance
 C_i = Maximum internal capacitance
 C_w = Field wiring capacitance

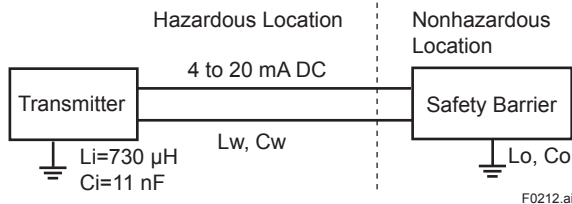

Figure 2.4 Diagram for Connecting Safety Barrier

2.10 EMC Conformity Standards

EN 61326-1 Class A, Table 2 (For use in industrial locations)

EN 61326-2-3

EN 61326-2-5 (for Fieldbus)

CAUTION

This instrument is a Class A product, and it is designed for use in the industrial environment. Please use this instrument in the industrial environment only.

NOTE

YOKOGAWA recommends customer to apply the Metal Conduit Wiring or to use the twisted pair Shield Cable for signal wiring to conform the requirement of EMC Regulation, when customer installs the EJA Series Transmitters to the plant.

2.11 PED (Pressure Equipment Directive)

EJA series of pressure transmitters are categorized as pressure accessories of this directive 97/23/EC, which corresponds to Article 3, Paragraph 3 of PED, denoted as Sound Engineering Practice (SEP).

2.12 Low Voltage Directive

Applicable standard: EN 61010-1

(1) Pollution Degree 2

“Pollution degree” describes the degree to which a solid, liquid, or gas which deteriorates dielectric strength or surface resistivity is adhering. “2” applies to normal indoor atmosphere. Normally, only non-conductive pollution occurs. Occasionally, however, temporary conductivity caused by condensation must be expected.

(2) Installation Category I

“Overvoltage category (Installation category)” describes a number which defines a transient overvoltage condition. It implies the regulation for impulse withstand voltage. “I” applies to electrical equipment which is supplied from the circuit when appropriate transient overvoltage control means (interfaces) are provided.

(3) Altitude of installation site:

Max. 2,000 m above sea level

(4) Indoor/Outdoor use

3. Component Names

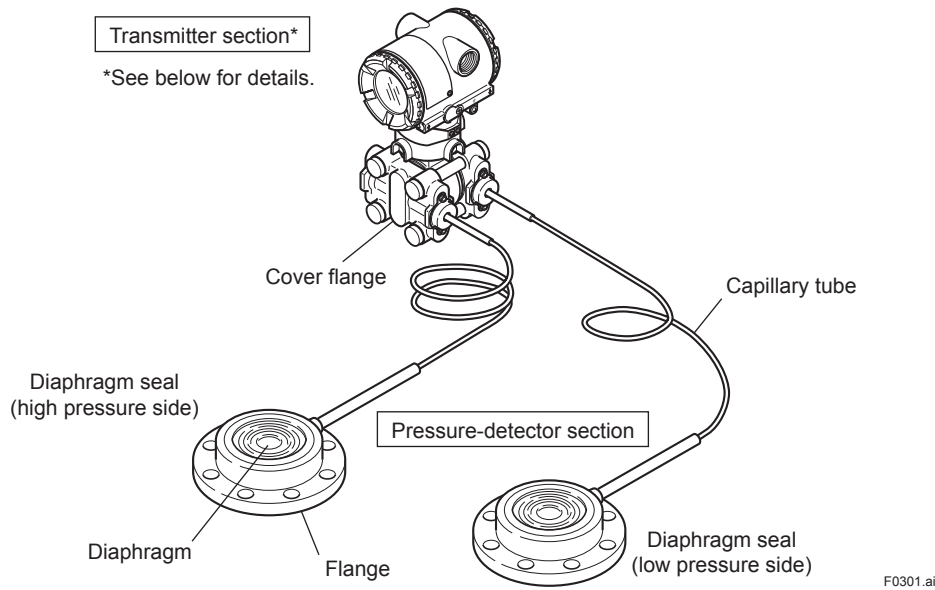
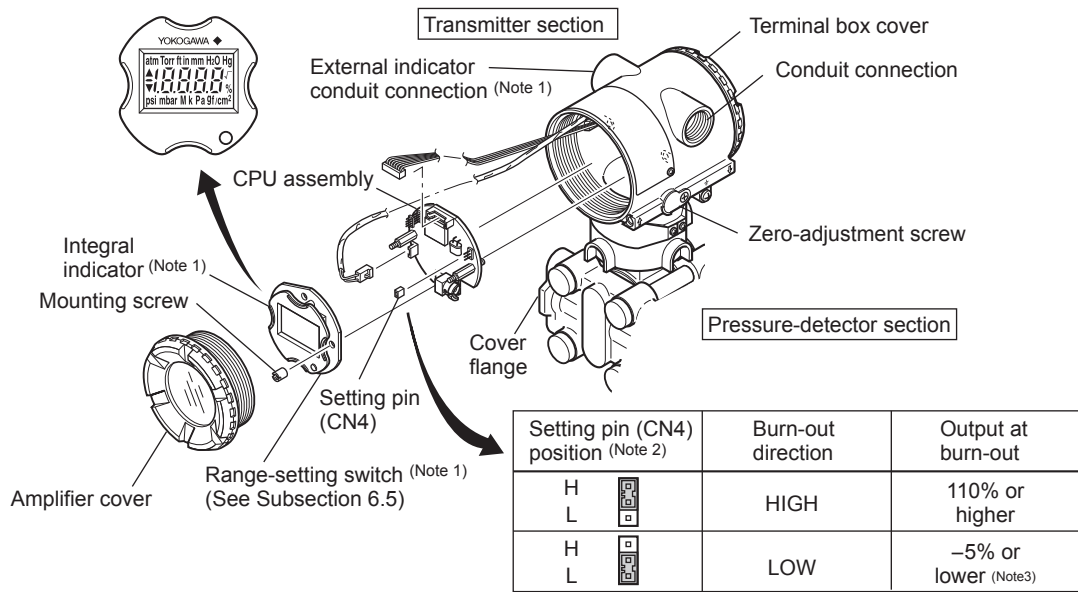

Figure 3.1 Component Names (Model EJA118W External View)



Note 1: Options depend on your order specifications. For details, see Subsection 9.2, "Model and Suffix Codes."
 Note 2: • Insert the pin (CN4) as shown in the above figure into the H or L side. The pin is set to the H side for delivery (unless option code /C1 is otherwise specified in the order).
 • The setting can be confirmed by calling up parameter D52 using the BRAIN TERMINAL. Refer to Subsection. 7.3.3 (11).
 Note 3: If optional code /F1 is specified, output signal is -2.5% or lower.

Display Symbol	Meaning of Display Symbol
$\sqrt{\quad}$	Display mode is "square root." (Display is not lit when "proportional" mode.)
▲	The output signal being zero-adjusted is increasing.
▼	The output signal being zero-adjusted is decreasing.
%, Pa, kPa, MPa, kgf/cm ² , gf/cm ² , mbar, bar, atm, mmHg, mmH ₂ O, inH ₂ O, inHg, ftH ₂ O, psi, Torr	Select one of these sixteen available engineering units for the display.

Figure 3.2 Component Names (Transmitter Section Details)

4. Installation

4.1 Precautions

Before installing the transmitter, read the cautionary notes in Section 2.4, "Selecting the Installation Location." For additional information on the ambient conditions allowed at the installation location, refer to Subsection 9.1 "Standard Specifications."



IMPORTANT

- When welding piping during construction, take care not to allow welding currents to flow through the transmitter.
- Do not step on this instrument after installation.

4.2 Mounting the Diaphragm Seals

Mount the diaphragm seals using the flanges as shown in Figure 4.1. Figure 4.2 shows how to mount the diaphragm seals on a tank. The customer should prepare the mating flange, gasket, bolts and nuts.

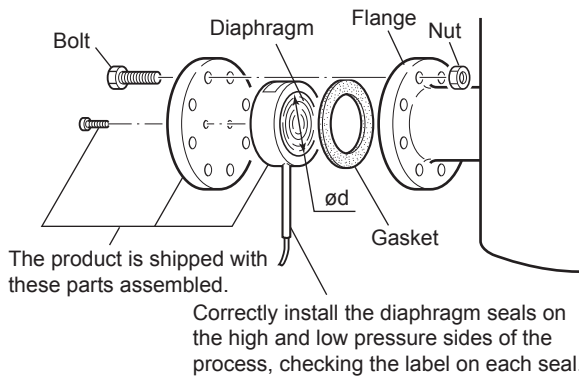

Figure 4.1 Mounting the Diaphragm Seals



IMPORTANT

Please use a gasket which has a bigger inside diameter than that of gasket facing (ød) on diaphragm seal. In case a gasket which has a smaller inside diameter than that of gasket facing is used, it may cause an error as the gasket prevents diaphragm from working correctly. (Refer to Subsection 9.4 'Dimensions')



IMPORTANT

- When measuring the liquid level of the tank, the minimum liquid level (zero point) must be set to a level at least 50 mm above the center of the high pressure side diaphragm seal (see Figure 4.2).
- Correctly install the diaphragm seals on the high and low pressure sides of the process, checking the label on each seal.
- To avoid measuring error due to temperature difference between the two diaphragm seals, capillary tube must be bound together. The capillary tube must be securely fixed to the tank wall to prevent movement by wind or vibration. If the capillary tube are too long, loosely coil the excess and secure using suitable clamps.
- During the diaphragm seal installation, ensure as far as possible that no seal liquid head is applied to the diaphragm seals.
- Exercise care so as not to damage diaphragm surfaces. Since the diaphragm protrudes approx. 1mm from the flange surface, placing the diaphragm seals with their diaphragm surfaces facing downward may damage the diaphragm surfaces.
- Do not sharply bend or twist capillary tube or apply excessive stress to them.



IMPORTANT

Install the sealed diaphragm so that the shank positions downward.

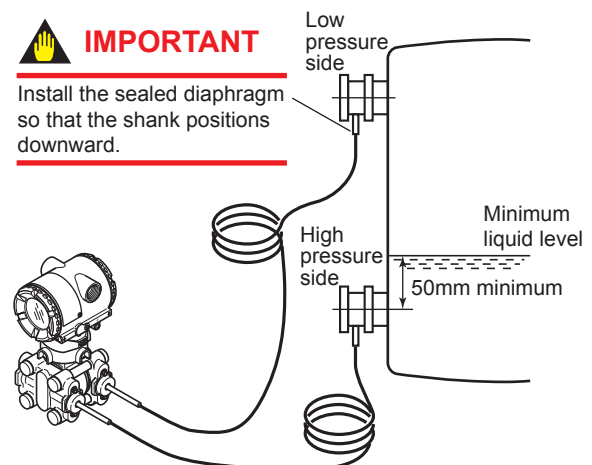

The transmitter should be installed as low as possible below the position where the high pressure side diaphragm seal is installed.

F0402.ai

Figure 4.2 Installing the Diaphragm Seals to a Tank

4.3 Transmitter Mounting

- The transmitter can be mounted on a nominal 50 mm (2-inch) pipe using the mounting bracket supplied, as shown in Figure 4.3. The transmitter can be mounted on either a horizontal or a vertical pipe.
- When mounting the bracket on the transmitter, tighten the (four) bolts that hold the transmitter to a torque of approximately 39 N·m {4 kgf·m}.

Vertical pipe mounting

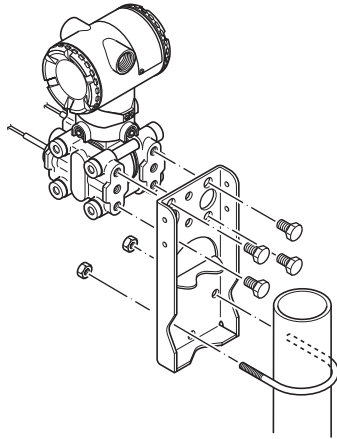

Horizontal pipe mounting

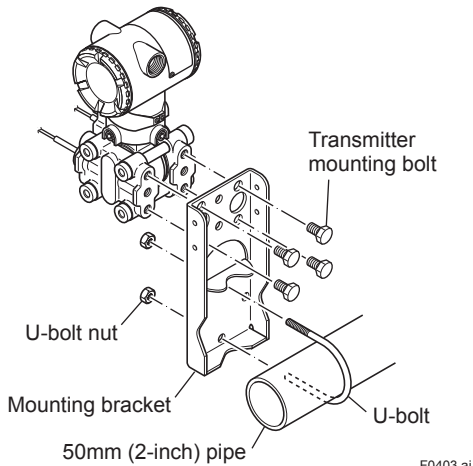

Figure 4.3 Transmitter Mounting



IMPORTANT

Never loosen the four screws securing the cover flange or the screws at the joints between the capillary tube and cover flanges (if the seal liquid leaks, the transmitter cannot be used).



IMPORTANT

The transmitter should be installed at least 600 mm below the high pressure (HP) process connection to ensure a positive head pressure of fill fluid. Pay special attention to vacuum applications. If it can not be installed at least 600 mm below the HP process connection, please use the equation below:

$$h = \frac{(P - P_0) \times dHg}{ds} \times 7.5 \times 10^{-3} \text{ [mm]}$$

- h: Vertical height between the HP process connection and the transmitter (mm)
- h ≤ 0: Install the transmitter at least h (mm) below the HP process connection
- h > 0: Install the transmitter at most h (mm) above the HP process connection

P: Pressure in the tank (Pa abs)

P0: Minimum working pressure limit of the transmitter (Pa abs)

If the ambient temperature range is -10 to 50°C.

3178 (Wetted parts material code S)

3596 (Wetted parts material code T)

6074 (Wetted parts material code H)

4711 (Wetted parts material code U)

ds: Specific gravity of fill fluid (at 25°C), refer to GS 01C22H01-00E.

dHg: Specific gravity of the Mercury 13.6 (at 25°C)

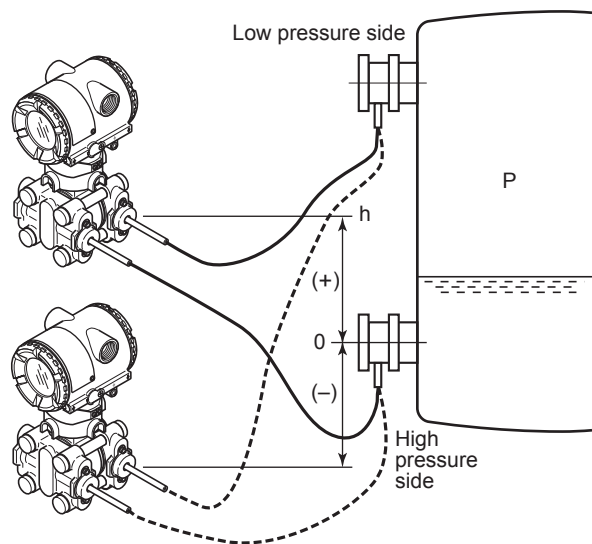

Figure 4.4 Example of Installation to Tank (Caution on Installation)

4.4 Affixing the Teflon Film

The FEP Teflon option includes a teflon film and fluorinated oil.

Before mounting the diaphragm seal to the process flange, affix the teflon film as follows:



IMPORTANT

- Position the diaphragm seal so that the diaphragm is in an upward position.
- Pour the fluorinated oil on the diaphragm and gasket area covering it completely and evenly. Be careful not to scratch the diaphragm or change its shape.
- Affix the teflon film over the diaphragm and gasket area.
- Next, carefully inspect the cover and try to identify any entrapped air between the diaphragm and the teflon film. The air must be removed to ensure accuracy. If air pockets are present, use your fingers to remove the air by starting at the center of the diaphragm and work your way out.
- Place the gasket with the teflon film and affix to the process flange.

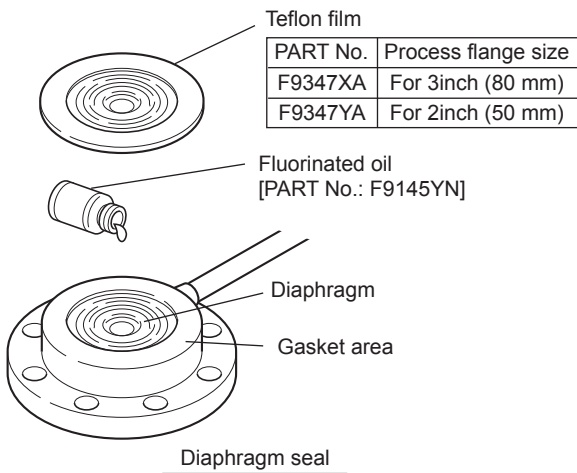

Figure 4.5 Affixing the Teflon Film

4.5 Rotating Transmitter Section

The DPharp transmitter section can be rotated in 90° segments.

- (1) Remove the two Allen screws that fasten the transmitter section and pressure-detector section, using the Allen wrench supplied with the transmitter.

- (2) Rotate the transmitter section slowly in 90° segments.
- (3) Tighten the two Allen screws.



IMPORTANT

Do not rotate the transmitter section more than 180°.

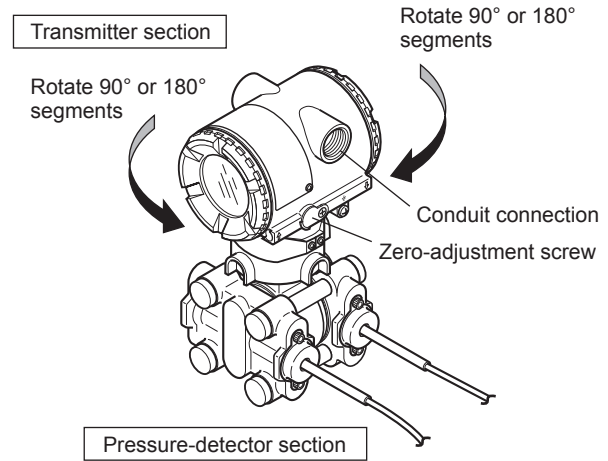

F0406.ai

Figure 4.6 Rotating Transmitter Section

4.6 Changing the Direction of Integral Indicator



IMPORTANT

Always turn OFF power, release pressure and remove a transmitter to non-hazardous area before disassembling and reassembling an indicator.

An integral indicator can be installed in the following three directions. Follow the instructions in section 8.4 for removing and attaching the integral indicator.

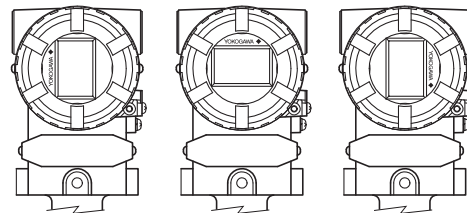

F0407.ai

Figure 4.7 Integral Indicator Direction

5. Wiring

5.1 Wiring Precautions



IMPORTANT

- Lay wiring as far as possible from electrical noise sources such as large capacity transformers, motors, and power supplies.
- Remove electrical connection dust cap before wiring.
- All threaded parts must be treated with waterproofing sealant. (A non-hardening silicone group sealant is recommended.)
- To prevent noise pickup, do not pass signal and power cables through the same ducts.
- Explosion-protected instruments must be wired in accordance with specific requirements (and, in certain countries, legal regulations) in order to preserve the effectiveness of their explosionprotected features.
- The terminal box cover is locked by an Allen head bolt (a shrouding bolt) on CENELEC, IECEx, and TIIS flameproof type transmitters.

When the shrouding bolt is driven clockwise by an Allen wrench, it is going in and cover lock is released, and then the cover can be opened.

See Subsection 8.4 “Disassembly and Reassembly” for details.

Refer to The “Installation and Operating Precautions for TIIS Flameproof Equipment” and “Installation and Operating Precautions for TIIS Intrinsically Safe Equipment” at the end of this manual for correct wiring.

5.2 Selecting the Wiring Materials

- Use stranded leadwires or cables which are the same as or better than 600 V grade PVC insulated wire (JIS C3307) or equivalent.
- Use shielded wires in areas that are susceptible to electrical noise.
- In areas with higher or lower ambient temperatures, use appropriate wires or cables.



CAUTION

If the transmitter is flameproof and the ambient temperature is 50°C or more, use cables having a maximum allowable heat resistance of at least 75°C in consideration of the instrument's generation of heat or the cables' self-heating.

- In environment where oils, solvents, corrosive gases or liquids may be present, use wires or cables that are resistant to such substances.
- It is recommended that crimp-on solderless terminal lugs (for 4 mm screws) with insulating sleeves be used for leadwire ends.

5.3 Connections of External Wiring to Terminal Box

5.3.1 Power Supply Wiring Connection

Connect the power supply wiring to the SUPPLY + and – terminals.

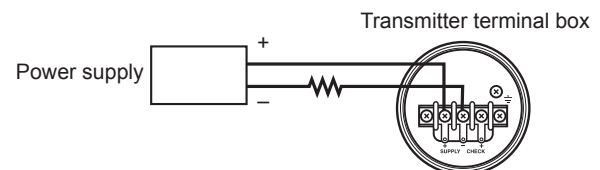

F0501.ai

Figure 5.1 Power Supply Wiring Connection

5.3.2 External Indicator Connection

Connect wiring for external indicators to the CHECK + and – terminals.

(Note) Use a external indicator whose internal resistance is 10Ω or less.

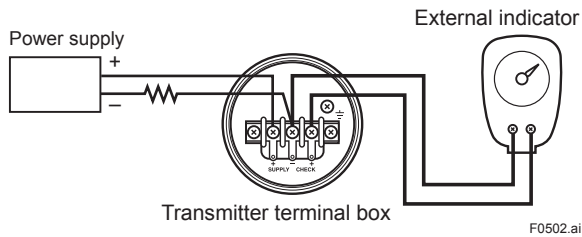

Figure 5.2 External Indicator Connection

5.3.3 BRAIN TERMINAL BT200 Connection

Connect the BT200 to the SUPPLY + and – terminals (Use hooks). The communication line requires a reception resistor of 250 to 600Ω in series.

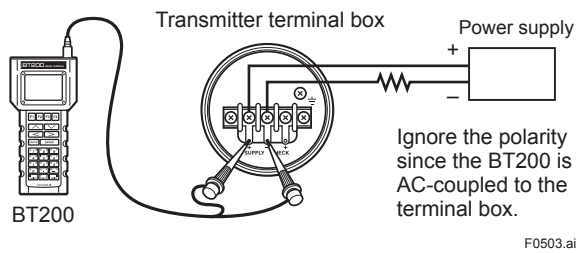

Figure 5.3 BT200 Connection

5.3.4 Check Meter Connection

Connect the check meter to the CHECK + and – terminals (use hooks).

- A 4 to 20 mA DC output signal from the CHECK + and – terminals.

(Note) Use a check meter whose internal resistance is 10Ω or less.

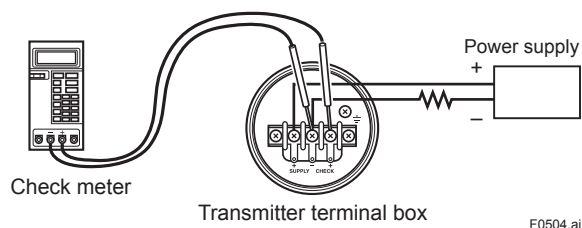

Figure 5.4 Check Meter Connection

5.4 Wiring



For the intrinsically safe equipment and flameproof equipment, wiring materials and wiring work for these equipment including peripherals are strictly restricted. Users absolutely must read “Installation and Operating Precautions for TIIS Intrinsically Safe Equipment” and “Installation and Operating Precautions for TIIS Flameproof Equipment” at the end of this manual prior to the work.

5.4.1 Loop Configuration

Since the DPharp uses a two-wire transmission system, signal wiring is also used as power wiring.

DC power is required for the transmitter loop. The transmitter and distributor are connected as shown below.

For details of the power supply voltage and load resistance, see Section 5.6; for communications line requirements, see Subsection 7.1.2.

(1) General-use Type and Flameproof Type

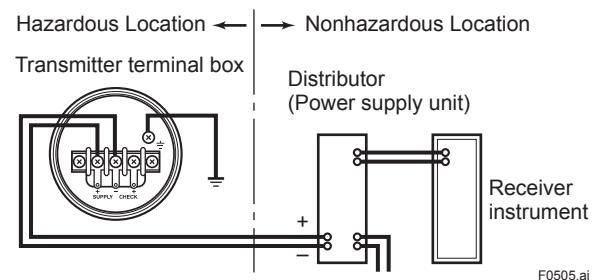

Figure 5.5 Connection between Transmitter and Distributor

(2) Intrinsically Safe Type

For intrinsically safe type, a safety barrier must be included in the loop.

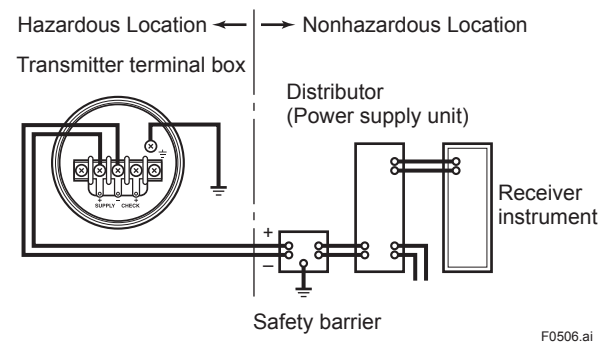

Figure 5.6 Connection between Transmitter and Distributor

5.4.2 Wiring Installation

(1) General-use Type and Intrinsically Safe Type

Make cable wiring using metallic conduit or waterproof glands.

- Apply a non-hardening sealant to the terminal box connection port and to the threads on the flexible metal conduit for waterproofing.

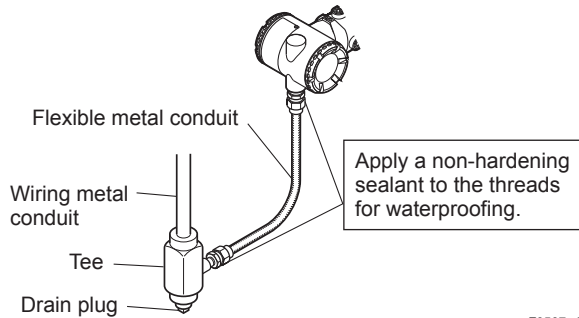

F0507.ai

Figure 5.7 Typical Wiring Using Flexible Metal Conduit

(2) Flameproof Type

Wire cables through a flameproof packing adapter, or using a flameproof metal conduit.

- Wiring cable through flameproof packing adapter for only TIIS flameproof type (see Figure 5.8).
 - Use only flameproof packing adapters approved by Yokogawa.
 - Apply a nonhardening sealant to the terminal box connection port and to the threads on the flameproof packing adapter for waterproofing.

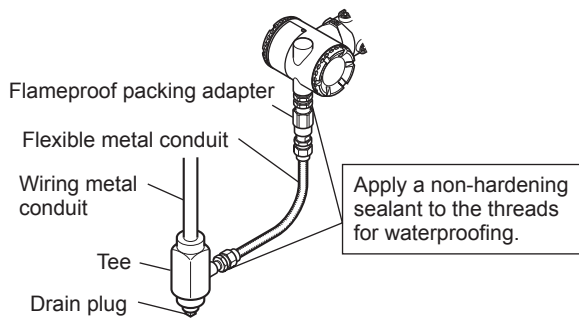

F0508.ai

Figure 5.8 Typical Cable Wiring Using Flameproof Packing Adapter

- Measure the cable outer diameter in two directions to within 1 mm.
- Calculate the average of the two diameters, and use packing with an internal diameter nearest to this value (see Table 5.1).

Table 5.1 Flameproof Packings and Applicable Cable Outer Diameters

Optional Code	Wiring Port Thread Diameter	Applicable Cable OD (mm)	Identifying Mark	Part Number
G11	G 1/2	8 to 10	16 8-10	G9601AM
G12		10.1 to 12	16 10-12	

- Mounting flameproof packing adapter body to conduit connection (see Figure 5.9)
 - 1) Screw the flameproof packing adapter into the terminal box until the O-ring touches the wiring port (at least 6 full turns), and firmly tighten the lock nut.
 - 2) Insert the cable through the union cover, the union coupling, the clamp nut, the clamp ring, the gland, the washer, the rubber packing, and the packing box, in that order.
 - 3) Insert the end of the cable into the terminal box.
 - 4) Tighten the union cover to grip the cable. When tightening the union cover, tighten approximately one turn past the point where the cable will no longer move up and down. Proper tightening is important. If it is too tight, a circuit break in the cable may occur; if not tight enough, the flameproof effectiveness will be compromised.
 - 5) Fasten the cable by tightening the clamp nut.
 - 6) Tighten the lock nut on the union cover.
 - 7) Connect the cable wires to each terminal.

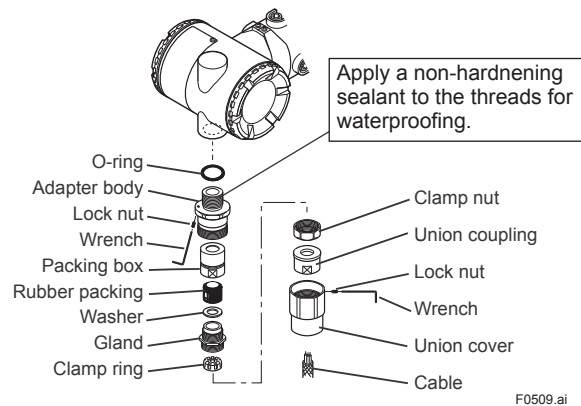

F0509.ai

Figure 5.9 Installing Flameproof Packing Adapter

■ Flameproof metal conduit wiring

- A seal fitting must be installed near the terminal box connection port for a sealed construction.
- Apply a non-hardening sealant to the threads of the terminal box connection port, flexible metal conduit and seal fitting for waterproofing.

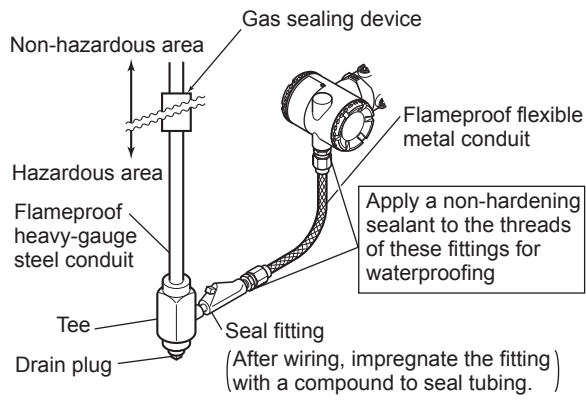

F0510.ai

Figure 5.10 Typical Wiring Using Flameproof Metal Conduit

5.5 Grounding

Grounding is always required for the proper operation of transmitters. Follow the domestic electrical requirements as regulated in each country. For a transmitter with built-in lightning protector, grounding should satisfy Class C requirements (ground resistance of 10Ω or less).

Ground terminals are located on the inside and outside of the terminal box. Either of these terminals may be used.



WARNING

For TIIS flameproof type and intrinsically safe, grounding should satisfy Class D requirements (grounding resistance, 100Ω or less).

Transmitter terminal box

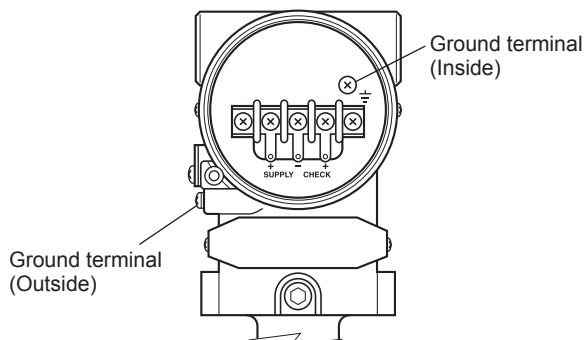

F0511.ai

Figure 5.11 Ground Terminals

5.6 Power Supply Voltage and Load Resistance

When configuring the loop, make sure that the external load resistance is within the range in the figure below.

(Note) In case of an intrinsically safe transmitter, external load resistance includes safety barrier resistance.

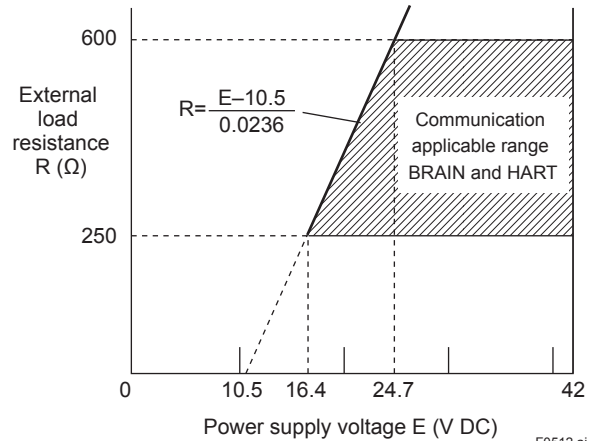

F0512.ai

Figure 5.12 Relationship between Power Supply Voltage and External Load Resistance

6. Operation

6.1 Preparation for Starting Operation

The Model EJA118W, EJA118N and EJA118Y diaphragm sealed differential pressure transmitter measures the flow rates of liquids, gases, and steam, liquid levels, and liquid densities. This section describes the operation procedure for the EJA118W as shown in Figure 6.1 when measuring liquid level in a closed tank.

- (a) Confirm that there is no leak in the connecting part of each diaphragm seal mounting flange.
- (b) Turn ON power and connect the BT200. Open the terminal box cover and connect the BT200 to the SUPPLY + and –terminals.
- (c) Using the BT200, confirm that the transmitter is operating properly. Check parameter values or change the setpoints as necessary. For BT200 operating procedures, see Chapter 7. If the transmitter is equipped with an integral indicator, its indication can be used to confirm that the transmitter is operating properly.

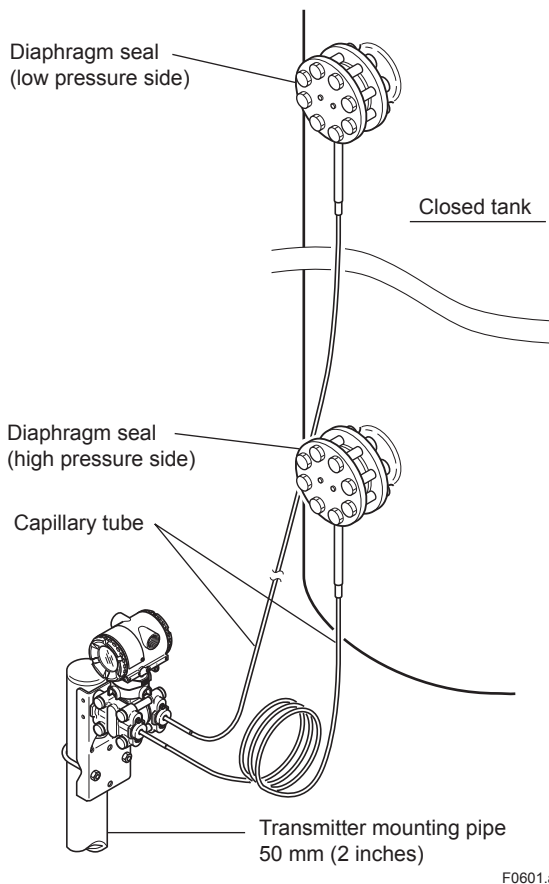

F0601.ai

Figure 6.1 Liquid Level Measurement in a Closed Tank

■ Confirming that Transmitter is Operating Properly

Confirmation using the BT200

- If the wiring system is faulty, 'communication error' appears on the display.
- If the transmitter is faulty, 'SELF CHECK ERROR' appears on the display.

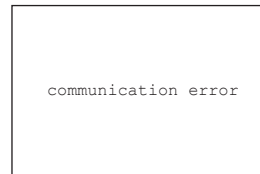

Communication error (Faulty wiring)

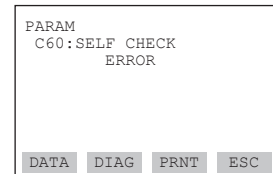

Self-diagnostic error (Faulty transmitter)

F0602.ai

Confirmation using the integral indicator

- If the wiring system is faulty, the display is blank.
- If the transmitter is faulty, an error number will appear on the display according to the nature of the error.

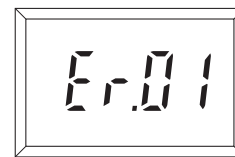

Self-diagnostic error (Faulty transmitter)

F0603.ai



NOTE

If any of the error indications above appears on the display of the integral indicator or BT200, refer to Subsection 7.5.2 for corrective action.

■ Verify and Change Transmitter Parameter Setting and Values

The following parameters are the minimum settings required for operation. The transmitter has been shipped with these parameters. To confirm or change the values, see Subsection 7.3.3.

- Measuring range ... See Subsection 7.3.3 (2)
- Output/integral indicator mode ... See Subsection 7.3.3 (4)
- Operation mode ... See Subsection 7.3.3 (9)

6.2 Zero Point Adjustment

Adjust the zero point after operating preparation is completed.



IMPORTANT

Do not turn off the power to the transmitter immediately after a zero adjustment. Powering off within 30 seconds after a zero adjustment will return the adjustment back to the previous settings.

The zero point adjustment can be made in either way: using the zero-adjustment screw of the transmitter or the BT200 operation.

For output signal checking, display the parameter **A10: OUTPUT (%)** in the BT200.

● BT200

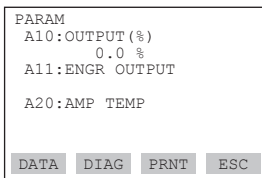

Output signal (%) display

● Zero-adjustment Screw

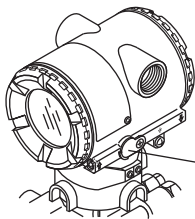

Zero-adjustment screw

F0604.ai

When adjusting the transmitter zero point, the liquid level in a tank does not have to be set to the low limit (0%) of the measuring range. In such case, match the transmitter output signal with the actual measured value using a glass gauge, for example.

6.2.1 When you can obtain Low Range Value from actual measured value of 0% (0 kPa, atmospheric pressure);

■ Using the Transmitter Zero-adjustment Screw

Before adjusting a screw, check that the parameter **J20: EXT ZERO ADJ** displays **ENABLE**. See Subsection 7.3.3 (12) for the setting procedure.

Use a slotted screwdriver to turn the zero-adjustment screw. Turn the screw clockwise to increase the output or counterclockwise to decrease the output. The zero point adjustment can be made with a resolution of 0.01% of the setting range. Since the degree of zero adjustments varies with the screw turning speed, turn the screw slowly for fine adjustment and quickly for coarse adjustment.

■ Using the BT200

Zero point can be adjusted by simple key operation of the BT200.

Select parameter **J10: ZERO ADJ**, and press the ENTER key twice. The zero point will be adjusted automatically to the output signal 0% (4 mA DC). Confirm that the setting value displayed for the parameter is '0.0%' before pressing the ENTER key. See Subsection 7.3.3 (12) for BT200 operating procedures.

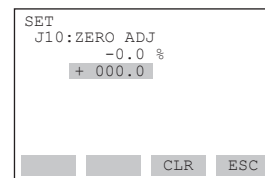

A display when parameter J10 is selected.

Press **ENTER** key twice for 0% output 4 mA DC.

F0605.ai

6.2.2 When you cannot obtain Low Range Value from actual measured value of 0%;

Convert the actual measured value obtained by a glass gauge into %.

[Example]

The measuring range of 0 to 2 m and the actual measured value of 0.8 m.

$$\text{Actual measured value} = \frac{0.8}{2} \times 100 = 40.0\%$$

■ Using the Transmitter Zero-Adjustment Screw

Turn the screw to match the output signal to the actual measured value in %.

■ Using the BT200

Select the parameter **J10: ZERO ADJ**. Change the set point (%) displayed for the parameter to the actual measured value (%), and press the ENTER key twice. See Subsection 7.3.3 (12) for operation details.

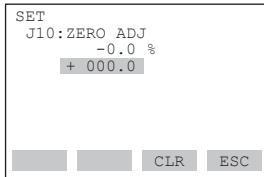

A display at J10

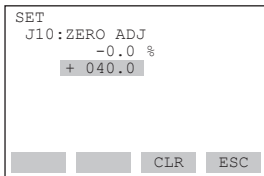

Change setting to the actually measured value (40.0%). Press **ENTER** key twice for 40% output 10.4 mA DC.

F0606.ai

6.3 Starting Operation

After completing the zero point adjustment, use the procedure below to start operation.

- 1) Confirm the operating status. There will be cases in which the output signal exhibits wide fluctuations (hunting) due to periodic variation in the process pressure. In such cases, BT200 operation can dampen the transmitter output signal. Confirm the hunting using a receiving instrument or the integral indicator, and set the optimum damping time constant. See Subsection 7.3.3 (3), "Damping Time Constant Setup."
- 2) After confirming the operating status, perform the following.



IMPORTANT

- Remove the BT200 from the terminal box, and confirm that none of the terminal screws are loosened.
- Close the terminal box cover and the amplifier cover. Screw each cover in tightly until it will not turn further.
- Two covers are required to be locked on the CENELEC, IECEx, and TIIS Flameproof type transmitters. An Allen head bolts (shrouding bolts) are provided under edge of the each cover for locking. When a shrouding bolts are driven counterclockwise by an Allen wrench, it is coming out and locks up a cover. (See page 8-4) After locking, the covers should be confirmed not to be opened.
- Tighten the zero-adjustment cover mounting screw to fix the cover in position.

6.4 Shutting Down Operation

Turn off the power.



NOTE

Whenever shutting down the transmitter for a long period, detach the transmitter (diaphragm seals) from the tank.

6.5 Setting the Range Using the Range-setting Switch

With actual pressure being applied to the transmitter, the range-setting switch (push-button) located on the optional integral indicator plate and the external zero-adjustment screw allow users to change (re-range) the low- and high-limit values for the measurement range (LRV and HRV) without using BT200. However, other changes in the display settings (scale range and engineering unit) for the integral indicator requires BT200.

Follow the procedure below to change the LRV and HRV settings.

[Example]

Rerange LRV to 0 and HRV to 3 MPa.

- 1) Connect the transmitter and apparatus as shown in Figure 8.1 and warm up for at least five minutes.
- 2) Press the range-setting push-button. The integral indicator then displays "LSET."
- 3) Apply a pressure of 0 kPa (atmospheric pressure) to the transmitter. (Note 1)
- 4) Turn the external zero-adjustment screw in the desired direction. The integral indicator displays the output signal in %. (Note 2)
- 5) Adjust the output signal to 0% (1 V DC) by rotating the external zero-adjustment screw. Doing so completes the LRV setting.
- 6) Press the range-setting push-button. The integral indicator then displays "HSET."
- 7) Apply a pressure of 3 MPa to the transmitter. (Note 1)
- 8) Turn the external zero-adjustment screw in the desired direction. The integral indicator displays the output signal in %. (Note 2)
- 9) Adjust the output signal to 100% (5 V DC) by rotating the external zero-adjustment screw. Doing so completes the HRV setting.
- 10) Press the range-setting push-button. The transmitter then switches back to the normal operation mode with the measurement range of 0 to 3 MPa.

Note 1: Wait until the pressure inside the pressure-detector section has stabilized before proceeding to the next step.

Note 2: If the pressure applied to the transmitter exceeds the previous LRV (or HRV), the integral indicator may display error number "Er.07" (In this case, the output signal percent and "Er.07" are displayed alternately every two seconds).

Although "Er.07" is displayed, you may proceed to the next step. However, should any other error number be displayed, take the appropriate measure in reference to Subsection 7.5.2, "Errors and Countermeasures."



IMPORTANT

- Do not turn off the power to the transmitter immediately after completion of the change in the LRV (and/or HRV) setting(s). Note that powering off within thirty seconds after setting will cause a return to the previous settings.
- Changing LRV automatically changes HRV to the following value.

HRV =

$$\text{previous HRV} + (\text{new LRV} - \text{previous LRV})$$

- If the range-setting push-button and external zero-adjustment screw are not touched during a range-change operation, the transmitter automatically switches back to the normal operation mode.

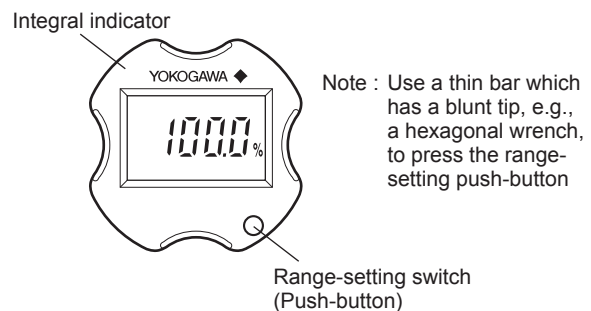

F0607.ai

Figure 6.2 Range-setting Switch

7. BRAIN TERMINAL BT200 Operation

The DPharp is equipped with BRAIN communications capabilities, so that range changes, Tag No. setup, monitoring of self-diagnostic results, and zero point adjustment can be handled by remote control via BT200 BRAIN TERMINAL or CENTUM CS console. This section describes procedures for setting parameters using the BT200. For details concerning the BT200, see IM 01C00A11-01E, "BT200 User's Manual."

7.1 BT200 Operation Precautions

7.1.1 Connecting the BT200

Connection to the transmitter with the BT200 can be made by either connecting to the BT200 connection hooks in the transmitter terminal box or by connecting to a relaying terminal board.

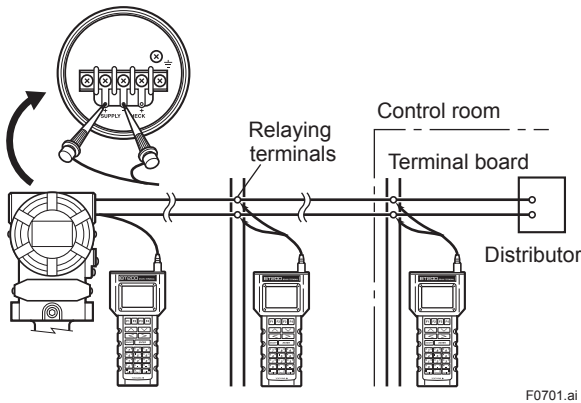

Figure 7.1 Connecting the BT200

• Note for Connecting the BT200



IMPORTANT

- Analog output may change temporally in connecting with BRAIN terminal due to an initial current flowed to it. To prevent communication signal affecting the upper system, it is recommended to install a low-pass filter (approximately 0.1s).
- Communication signal is superimposed on analog output signal. It is recommended to set a low-pass filter (approximately 0.1s) to the receiver in order to reduce the output effect from communication signal. Before online-communication, confirm that communication signal does not give effect on the upper system.

7.1.2 Conditions of Communication Line

• Communication Line Requirements

[Protocol specification] Yokogawa original protocol

[Modulation] Burst modulation

0: 2400Hz

1: Signal without carrier

[Baud rate] 1200bps

[Communication signal]

host to device: +/- 0.5V (load resistance 250Ω)

device to host: +/- 2mA

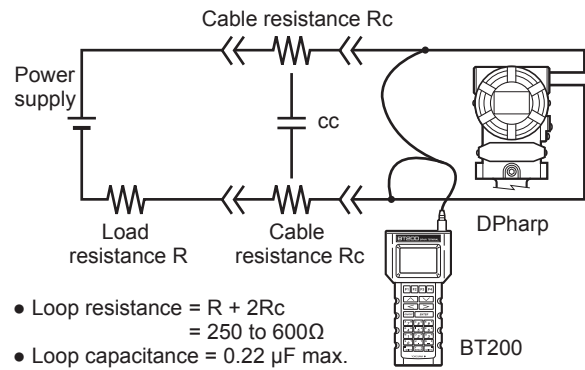

- Loop resistance = $R + 2R_c$
= 250 to 600Ω
- Loop capacitance = 0.22 μF max.

Figure 7.2 Conditions of Communication Line

7.2 BT200 Operating Procedures

7.2.1 Key Layout and Screen Display

Figure 7.3 shows the arrangement of the operating keys on the BT200 keypad, and Figure 7.4 shows the BT200 screen component.

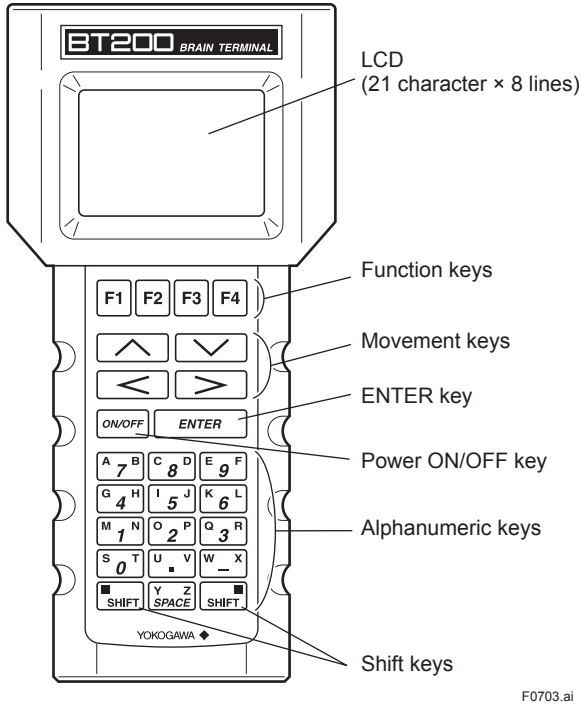

Figure 7.3 BT200 Key Layout

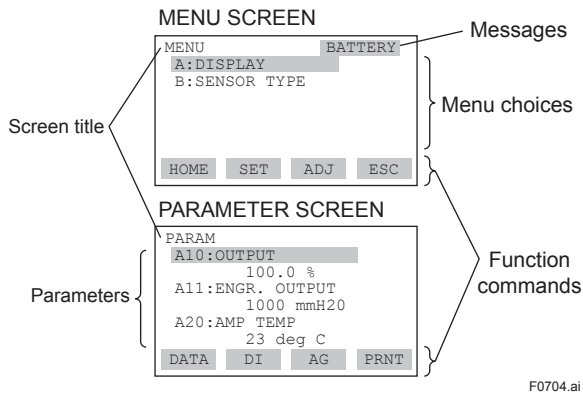
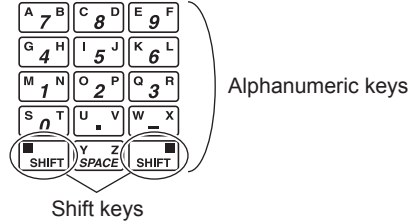

Figure 7.4 BT200 Screen Component

7.2.2 Operating Key Functions

(1) Alphanumeric Keys and Shift Keys

You can use the alphanumeric keys in conjunction with the shift keys to enter symbols, as well as alphanumeric keys.



a. Entering Digits, Symbols, and Spaces

Simply press the alphanumeric keys.

Entry	Key-in Sequence
-4	[W - X] [G 4 H]
0.3	[S 0 T] [U . V] [Q 3 R]
1 _ -9	[M 1 N] [Y SPACE Z] [W - X] [E 9 F]

F0706.ai

b. Entering Letters (A through Z)

Press an alphanumeric key following a shift key to enter the letter shown on that side which the shift key represents. You must press the shift key before entering each letter.

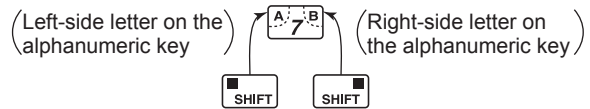

Entry	Key-in Sequence
W	[SHIFT] [W - X]
IC	[SHIFT] [I 5 J] [SHIFT] [C 8 D]
J. B	[SHIFT] [I 5 J] [U . V] [SHIFT] [A 7 B]

F0707.ai

Use the function key [F2] CAPS to select between uppercase and lowercase (for letters only). The case toggles between uppercase and lowercase each time you press [F2] CAPS.

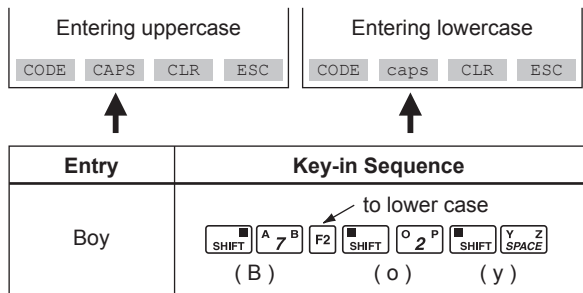

F0708.ai

Use the function key [F1] **CODE** to enter symbols.
 The following symbols will appear in sequence, one at a time, at the cursor each time you press [F1]
 CODE:

/ . - , + *) (' & % \$ # " !

To enter characters next to these symbols, press [>] to move the cursor.

Entry	Key-in Sequence
/m	

F0709.ai

(2) Function Keys

The functions of the function keys depend on the function commands on display.

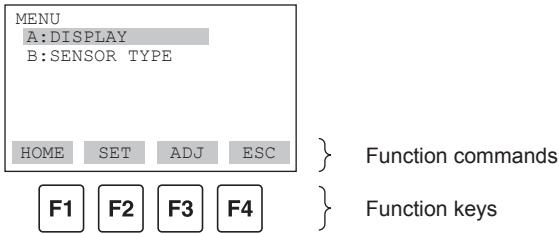

F0710.ai

Function Command List

Command	Function
ADJ	Displays the ADJ menu
CAPS/caps	Selects uppercase or lowercase
CODE	Selects symbols
CLR	Erases input data or deletes all data
DATA	Updates parameter data
DEL	Deletes one character
DIAG	Calls the self-check panel
ESC	Returns to the most recent display
HOME	Displays the menu panel
NO	Quits setup and returns to the previous display
OK	Proceeds to the next panel
PARM	Enters the parameter number setup mode
SET	Displays the SET menu
SLOT	Returns to the slot selection panel
UTIL	Calls the utility panel
*COPY	Prints out parameters on display
*FEED	Paper feed
*LIST	Lists all parameters in the menu
*PON/ POFF	Automatic printout mode on or off
*PRNT	Changes to the print mode
*GO	Starts printing
*STOP	Cancels printing

* Available on BT200-P00 (with printer).

7.2.3 Calling Up Menu Addresses Using the Operating Keys

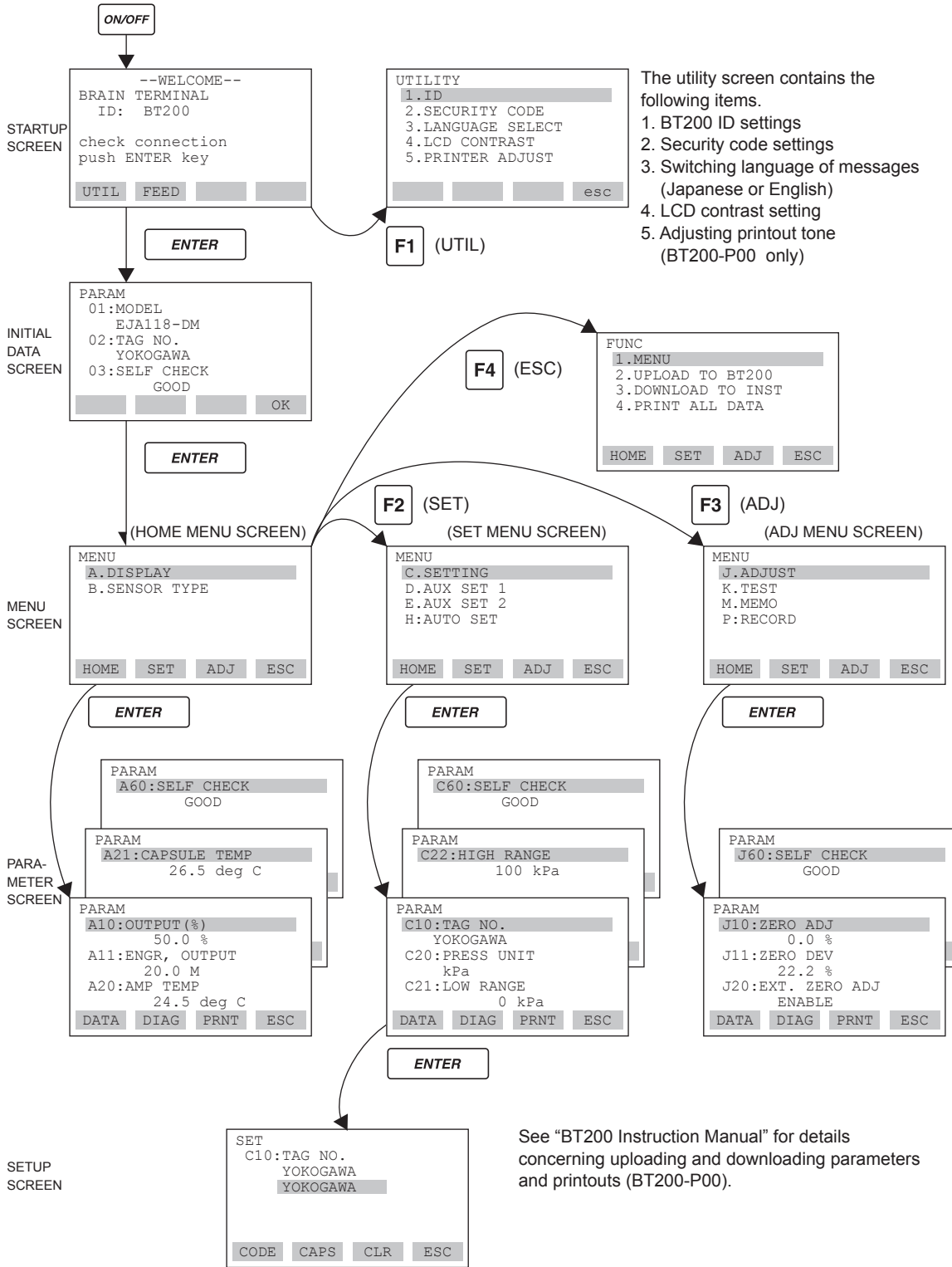

The utility screen contains the following items.

1. BT200 ID settings
2. Security code settings
3. Switching language of messages (Japanese or English)
4. LCD contrast setting
5. Adjusting printout tone (BT200-P00 only)

See "BT200 Instruction Manual" for details concerning uploading and downloading parameters and printouts (BT200-P00).

F0711.ai

7.3 Setting Parameters Using the BT200

7.3.1 Parameter Summary

Instruments to which applicable:

F: Differential pressure transmitters EJA110, EJA120, EJA118W, EJA118N, EJA118Y, and EJA115

P: Pressure transmitters EJA310, EJA430, EJA438W, and EJA438N

L: Liquid level transmitters EJA210 and EJA220

No.	Item	Description	Rewritability	Remarks	Default Value	Applicability		
						F	P	L
01	MODEL	Model+capsule type	–			○	○	○
02	TAG NO.	Tag number	–	16 alphanumerics		○	○	○
03	SELF CHECK	Self-diagnostic result	–	GOOD/ERROR		○	○	○
A	DISPLAY	Measured data display	–	Menu name		○	○	○
A10	OUTPUT (%)	Output (in %)	–	–5 to 110%*3		○	○	○
A11	ENGR. OUTPUT	Output (in engineering units)	–	–19999 to 19999		○	○	○
A20	AMP TEMP	Amplifier temperature	–	Unit specified in D30		○	○	○
A21	CAPSULE TEMP	Capsule temperature	–	Unit specified in D30		○	○	○
A30	STATIC PRESS	Static pressure	–	Unit specified in D31*1		○	–	○
A40	INPUT	Input (indicated as the value after zeroing)	–	–32000 to 32000		○	○	○
A60	SELF CHECK	Self-diagnostic messages	–	GOOD/ERROR, CAP MODULE FAULT, AMP MODULE FAULT, OUT OF RANGE, OUT OF SP RANGE*1, OVER TEMP (CAP), OVER TEMP (AMP), OVER OUTPUT, OVER DISPLAY, ILLEGAL LRV, ILLEGAL HRV, ILLEGAL SPAN, and ZERO ADJ OVER		○	○	○
B	SENSOR TYPE	Sensor type	–	Menu name		○	○	○
B10	MODEL	Model+span	–	16 uppercase alphanumerics		○	○	○
B11	STYLE NO.	Style number	–			○	○	○
B20	LRL	Lower range-limit	–	–32000 to 32000		○	○	○
B21	URL	Upper range-limit	–	–32000 to 32000		○	○	○
B30	MIN SPAN	Minimum span	–	–32000 to 32000		○	○	○
B40	MAX STAT.P.	Maximum static pressure*6	–			○	–	○
B60	SELF CHECK	Self-diagnostic messages	–	Same as A60		○	○	○
C	SETTING	Setting data	–	Menu name		○	○	○
C10	TAG NO.	Tag number	○	16 alphanumerics	As specified when ordered.	○	○	○
C20	PRESS UNIT	Measurement range units	○	Selected from mmH ₂ O, mmAq, mmWG, mmHg, Torr, Pa, hPa, kPa, MPa, mbar, bar, gf/cm ² , kgf/cm ² , inH ₂ O, inHg, ftH ₂ O, psi, or atm	As specified when ordered.	○	○	○
C21	LOW RANGE	Measurement range, lower range value	○	–32000 to 32000 (but within measurement range)	As specified when ordered.	○	○	○
C22	HIGH RANGE	Measurement range, higher range value	○	–32000 to 32000 (but within measurement range)	As specified when ordered.	○	○	○
C30	AMP DAMPING	Damping time constant	○	Selected from 0.2*2, 0.5, 1.0, 2.0, 4.0, 8.0, 16.0, 32.0, or 64.0 sec.	2.0 s	○	○	○
C40	OUTPUT MODE	Output mode and integral indicator mode	○	Selected from OUT:LIN; DSP:LIN; OUT:LIN; DSP:SQR; OUT:SQR; DSP:SQR	As specified when ordered. If not specified, OUT:LIN; DSP:LIN.	○	–	–
C60	SELF CHECK	Self-diagnostic messages	–	Same as A60		○	○	○

No.	Item	Description	Rewritability	Remarks	Default Value	Applicability		
						F	P	L
D	AUX SET 1	Auxiliary setting data 1	–	Menu name		○	○	○
D10	LOW CUT	Low cut	○	0.0 to 20.0%	10.0%	○	○	○
D11	LOW CUT MODE	Low cut mode	○	LINEAR/ZERO	LINEAR	○	○	○
D15	OUT LIMIT(L)	Lower output range-limit	○	–5.0 to 110.0%	–5.0%*7	○	○	○
D16	OUT LIMIT(H)	Upper output range-limit	○	–5.0 to 110.0%	110.0%	○	○	○
D20	DISP SELECT	Display selection	○	NORMAL %/USER SET, USER & %/INP PRES, PRES & %	As specified when ordered.	○	○	○
D21	DISP UNIT	Engineering unit for display	○	8 uppercase alphanumerics		○	○	○
D22	DISP LRV	Engineering range, lower range value	○	–19999 to 19999	As specified when ordered.	○	○	○
D23	DISP HRV	Engineering range, higher range value	○	–19999 to 19999	As specified when ordered.	○	○	○
D30	TEMP UNIT	Temperature setting units	○	deg C/deg F	deg C	○	○	○
D31	STAT. P. UNIT	Static pressure setting units	○	Selected from mmH ₂ O, mmAq, mmWG, mmHg, Torr, Pa, hPa, kPa, MPa, mbar, bar, gf/cm ² , kgf/cm ² , inH ₂ O, inHg, ftH ₂ O, psi, or atm	As specified when ordered. If not specified, MPa.	○	–	○
D40	REV OUTPUT	Output reversal	○	NORMAL/REVERSE	If not specified, NORMAL.	○	○	○
D45	H/L SWAP	Impulse piping accessing direction	○	NORMAL/REVERSE*4	NORMAL	○	–	–
D52	BURN OUT	CPU error	–	HIGH/LOW, –5 to 110%*3	HIGH	○	○	○
D53	ERROR OUT	Hardware error	○	HOLD/HIGH/LOW, –5 to 110%*3	HIGH	○	○	○
D60	SELF CHECK	Self-diagnostic messages	–	Same as A60		○	○	○
E	AUX SET 2	Auxiliary setting data 2	–	Menu name		○	○	○
E10	DFS MODE	DFS mode	○	OFF/ON*5	ON	○	○	–
E14	TEMP SELECT	Reference temperature sensor	○	AMP. TEMP/CAP. TEMP*5	CAP. TEMP	○	○	–
E15	TEMP ZERO	Zero shift compensation setup	○	±10.00*5	0.00	○	○	–
E30	BI DIRE MODE	Bidirectional mode	○	OFF/ON	OFF	○	–	–
E50	AUTO RECOVER	Auto-recover from sensor error	○	OFF/ON	ON	○	○	○
E60	SELF CHECK	Self-diagnostic messages	–	Same as A60		○	○	○
H	AUTO SET	Automatic setup	–	Menu name		○	○	○
H10	AUTO LRV	Automatic measurement range lower range value setup	○	–32000 to 32000	Displays the same data as C21.	○	○	○
H11	AUTO HRV	Automatic measurement range higher range value setup	○	–32000 to 32000	Displays the same data as C22.	○	○	○
H60	SELF CHECK	Self-diagnostic messages	–	Same as A60		○	○	○
J	ADJUST	Adjustment data	–	Menu name		○	○	○
J10	ZERO ADJ	Automatic zero adjustment	○	–5 to 110.0%*3		○	○	○
J11	ZERO DEV.	Manual zero adjustment	○			○	○	○
J15	SPAN ADJ	Manual span adjustment	○	–10.00 to 10.00%	0.00%	○	○	○
J20	EXT. ZERO ADJ	External zero-adjustment screw permission	○	ENABLE/INHIBIT		○	○	○
J30	AOUTPUT 4mA	4mA adjustment	○	–10.00 to 10.00%	0.00%	○	○	○
J31	OUTPUT 20mA	20mA adjustment	○	–10.00 to 10.00%	0.00%	○	○	○
J60	ASELF CHECK	Self-diagnostic messages	–	Same as A60		○	○	○
K	TEST	Tests	–	Menu name		○	○	○
K10	OUTPUT in %	Test output % setting	○	–5 to 110.0%*3 Displays 'ACTIVE' while executing		○	○	○
K60	SELF CHECK	Self-diagnostic messages	–	Same as A60		○	○	○

No.	Item	Description	Rewrita- bility	Remarks	Default Value	Applica- bility		
						F	P	L
M	MEMO	Memo	–	Menu name		○	○	○
M10	MEMO 1	Memo	○	8 uppercase alphanumerics		○	○	○
M20	MEMO 2	Memo	○	8 uppercase alphanumerics		○	○	○
M30	MEMO 3	Memo	○	8 uppercase alphanumerics		○	○	○
M40	MEMO 4	Memo	○	8 uppercase alphanumerics		○	○	○
M50	MEMO 5	Memo	○	8 uppercase alphanumerics		○	○	○
M60	SELF CHECK	Self-diagnostic messages	–	Same as A60		○	○	○
P	RECORD	History of the errors	–			○	○	○
P10	ERROR REC 1	Last error	○	Display the error		○	○	○
P11	ERROR REC 2	One time before	○	Display the error		○	○	○
P12	ERROR REC 3	Two time before	○	Display the error		○	○	○
P13	ERROR REC 4	Three time before	○	Display the error		○	○	○
P60	SELF CHECK	Self-diagnostic messages	–	Same as A60		○	○	○

*1: In case of Model EJA120A, static pressure cannot be measured. The display is always 0 MPa, but this is not a measured value.

*2: When Optional code /F1 is specified, substitute the value with 0.1.

*3: When Optional code /F1 is specified, substitute the value –5 with –2.5.

*4: Not applicable for Model EJA115.

*5: Applicable only for Model EJA118W, EJA118N, EJA118Y, EJA438W, and EJA438N.

*6: See MWP(max. working pressure) on the nameplate. B40 shows an approximate value of maximum pressure for the capsule.

*7: Unless otherwise specified by order. When optional code /F1 is specified, substitute the value –5 with –2.5.

7.3.2 Parameter Usage and Selection

Before describing the procedure for setting parameters, we present the following table showing how the parameters are used and in what case.



IMPORTANT

If the transmitter is turned off within 30 seconds after parameters have been set, the set data will not be stored and the terminal returns to previous settings.

Table 8.1 Parameter Usage and Selection

Setup Item	Description
Tag No. setup P. 7-9	Sets the Tag No. (using 16 alphanumeric characters). Note: Up to 8 alphanumerics (upper case letters) can be used in the BT100.
Calibration range setup P. 7-9	Sets the calibration range for 4 to 20 mA DC. Sets three data items: range unit, input value at 4 mA DC (LRV), and input value at 20 mA DC (HRV). Note: LRV and HRV can be specified with range value specifications up to 5 digits (excluding any decimal point) within the range of –32000 to 32000.
Damping time constant setup P. 7-10	Adjusts the output response speed for 4 to 20 mA DC. Can be set in 9 increments from 0.2 to 64 s.
Output and integral indicator display mode setup P. 7-11	Sets modes for output signal and integral indicator to “Linear mode” (proportional to input differential pressure) or to “Square root mode” (proportional to flow).
Output signal low cut mode setup P. 7-11	Used mainly to stabilize output near 0% if output signal is the square root mode. Two modes are available: forcing output to 0% for input below a specific value, or changing to proportional output for input below a specific value.
Change the output limits P. 7-11	Change the range of normal output.

Setup Item	Description
Integral indicator scale range and unit setup P. 7-12	Sets the following 5 types of integral indicator scale ranges and units: % scale indicator, user set scale indicator, alternate indication of user set scale and % scale, input pressure display, alternate indication of input pressure and % scale When using the user set scale, 4 types of data can be set: user set scale setting, unit (BT200 only), display value at 4 mA DC (LRV), and display value at 20 mA DC (HRV). Note: LRV and HRV can be specified with range value specifications up to 5 digits (excluding any decimal point) within the range of -19999 to 19999.
Unit setup for displayed temperature P. 7-13	Sets a unit for temperatures displayed on the BT200.
Unit setup for displayed static pressure P. 7-14	Sets a unit for static pressure displayed on the BT200.
Operation mode (normal/reverse signal) setup P. 7-14	Reverses the direction for 4 to 20 mA DC output relative to input. Reverse mode is used for applications in which safety requires that output be driven toward 20 mA if input is lost.
Impulse line connection orientation (higher pressure on right/left side) setup P. 7-14	Used where installation conditions make it imperative to connect high pressure side impulse line to low pressure side of transmitter. Reversal of orientation should be dealt with by reversing impulse line wherever possible. Use this function only where there is no alternative.
Output status display/setup when a CPU failure P. 7-14	Displays the status of 4 to 20 mA DC output when a CPU failure. The parameter of the standard unit is fixed to the high limit value.
Output status setup when a hardware error occurs P. 7-15	Sets the status of the 4 to 20 mA DC output when an abnormal status is detected with the capsule or the amplifier as the result of self-diagnosis. One of the following statuses; last held, high limit, and low limit values, can be selected.
Bi-directional flow measurement P. 7-15	Used to measure bi-directional flows. Output at zero flow is 12 mA DC, with output range equally divided between forward and reverse flow. Can be used with square root mode.
Range change (while applying actual inputs) P. 7-16	Range for 4 to 20 mA DC signal is set with actual input applied. Sets 20 mA DC output precisely with respect to user's reference instrument output. Note that DPharp is calibrated with high accuracy before shipment, so span should be set using the normal range setup.
Zero point adjustment P. 7-17	Adjusts zero point. This can be done either using the external zero-adjustment screw on the transmitter or using the BT200.
Span adjustment P. 7-18	Adjust the characterization curve. All the transmitters are calibrated at factory and this adjustment is normally not necessary for most cases. Use for specific purposes.
Test output (fixed current output) setup P. 7-19	Used for loop checks. Output can be set freely from -5% to 110% in 1% steps.
Ambient temperature zero shift compensation P. 7-19	Allows user to compensate the zero shift by ambient temperature effect on capillary tubes.
User memo fields P. 7-20	Allows user to enter up to 5 items of any desired text in up to 8 uppercase alphanumeric characters per item.

7.3.3 Setting Parameters

Set or change the parameters as necessary. After completing these, do not fail to use the “DIAG” key to confirm that “GOOD” is displayed for the self-diagnostic result at **_60: SELF CHECK**.

(1) Tag No. Setup (C10: TAG NO)

Use the procedure below to change the Tag No. Up to 16 alphanumeric characters can be entered.

- Example: Set a Tag No. to FIC-1a

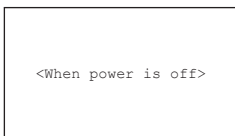

Press the **ON/OFF** key to turn on the BT200.



Connect DPharp and BT200 using a communication cable and press the **ENTER** key.

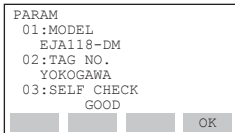

Displays the name of connected DPharp model, TAG NO. and diagnostics information. Press the **F4** (OK) key after confirmation.

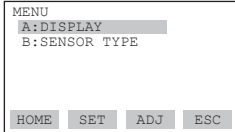

Press the **F2** (SET) key to display the SET menu panel.

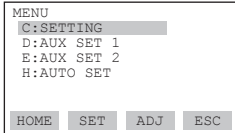

Select C: SETTING and press the **ENTER** key.

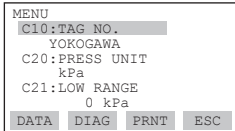

Select C10: TAG NO. and press the **ENTER** key.

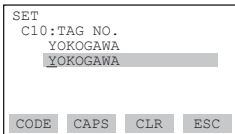

Set the new TAG NO. (FIC-1a).

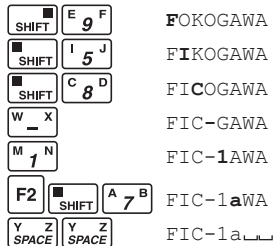

F0712-1.ai

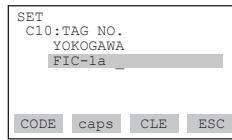

Set TAG NO. and press the **ENTER** key.

(When you have made an entry mistake, return the cursor **<** using the key, then reenter.)

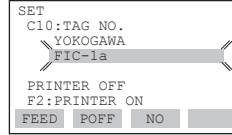

This is the panel for confirming set data. The set data items flash. When all items have been confirmed, press the **ENTER** again. (To go back to the setting panel, press the **F3** (NO) key.

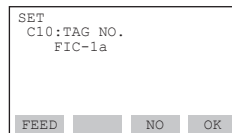

The DPharp TAG NO. was overwritten.

Press the **F4** (OK) key to return to the parameter panel. Press the **F3** (NO) key to return to the setting panel.

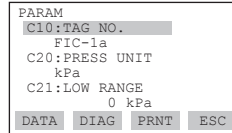

F0712-2.ai

(2) Calibration Range Setup

a. Setting Calibration Range Unit (C20: PRESS UNIT)

The unit is set at the factory before shipment if specified at the time of order. Follow the procedure below to change the unit.

- Example: Change the unit from mmH₂O to kPa.

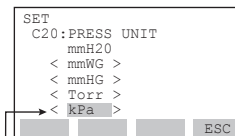

Use the **↑** or **↓** key to select “kPa.”

Press the **ENTER** key twice to enter the setting.

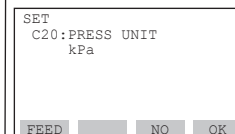

Press the **F4** (OK) key.

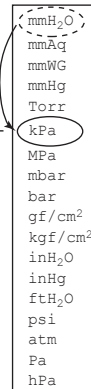

F0713.ai

b. Setting Calibration Range Lower Range Value and Higher Range Value (C21: LOW RANGE, C22: HIGH RANGE)

These range values are set as specified in the order before the instrument is shipped. Follow the procedure below to change the range.

- The measurement span is determined by the high and low range limit values. In this instrument, changing the low range value also automatically changes the high range value, keeping the span constant.

- Example 1: With present settings of 0 to 30 kPa, set the lower range value to 0.5 kPa.

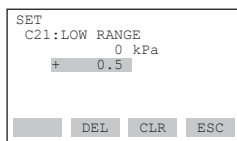

Set **0.5**.
Press the **ENTER** key twice to enter the setting.

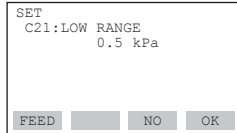

Press the **F4** (OK) key.

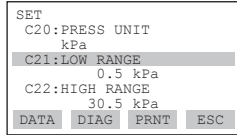

The higher range value is changed while the span remains constant.

(Span = Higher range value – Lower range value)

F0714.ai

- Note, however, that changing the higher range value does not cause the lower range value to change. Thus, changing the higher range value also changes the span.
- Calibration range can be specified with range value specifications up to 5 digits (excluding any decimal point) for low or high range limits within the range of -32000 to 32000.

- Example 2: With present settings of 0 to 30 kPa, set the Higher range value to 10 kPa.

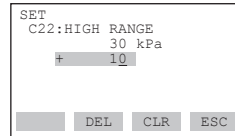

Set **10**.
Press the **ENTER** key twice to enter the setting.

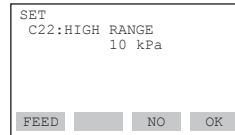

Press the **F4** (OK) key.

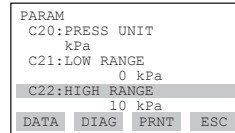

The low range value is not changed, so the span changes.

F0715.ai

(3) Damping Time Constant Setup (C30: AMP DAMPING)

When the instrument is shipped, the damping time constant is set at 2.0 seconds. Follow the procedure below to change the time constant.

- Example: Change from 2.0 sec to 4.0 sec.

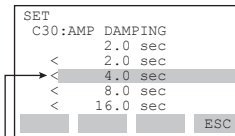

Use the **▲** or **▼** key to select **4.0 sec**.
Press the **ENTER** key twice to enter the setting.

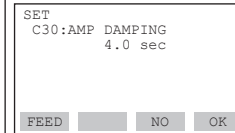

Press the **F4** (OK) key.

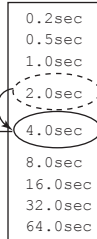

F0716.ai

Note: The damping time constant set here is the damping time constant for the amplifier assembly. The damping time constant for the entire transmitter is the sum of the values for the amplifier assembly and for the capsule assembly. For the capsule assembly damping time constant (fixed), see the "General Specifications" found at the end of this manual. (See Chapter 9.)

When optional code /F1 is specified, the minimum value for setting becomes 0.1 seconds.

**(4) Output Mode and Integral Indicator Display Mode Setup
(C40: OUTPUT MODE)**

The mode setting for the output signal and the integral indicator coordinate as shown in the table below.

BT200 Display	Output Mode	Integral Indicator Display Mode
OUT: LIN DSP: LIN	Linear	Linear
OUT: LIN DSP: SQR	Linear	Square root
OUT: SQR DSP: SQR	Square root	Square root



This mode is set as specified in the order when the instrument is shipped. Follow the procedure below to change the mode.

If the instrument is equipped with an integral indicator and the display mode is “square root”, “√” is displayed on the integral indicator.

For details, see Chapter 3.

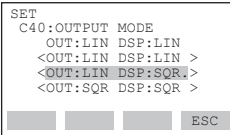
• Example: Set output mode to **Linear** and display mode to **Square root**.



Use the  or  key to select “OUT: LIN, DSP: SQR.”

Press the  key twice to enter the setting.

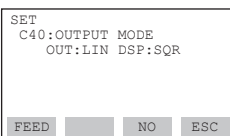

Press the  (OK) key.

F0717.ai

**(5) Output Signal Low Cut Mode Setup
(D10: LOW CUT, D11: LOW CUT MODE)**

Low cut mode can be used to stabilize the output signal near the zero point. The low cut point can be set in a range from 0 to 20% of output. (Hysteresis of cut point: ±1%)

Either “**LINEAR**” or “**ZERO**” can be selected as the low cut mode.

- Low cut mode “**LINEAR**”
- Low cut mode “**ZERO**”

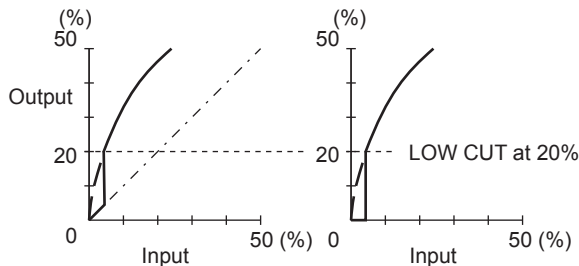

- Example: Change the low cut setting range from 10% to 20%, and the low cut mode from **LINEAR** to **ZERO**.

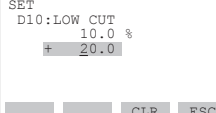

Set “20.”



Press the  key twice to enter the setting.

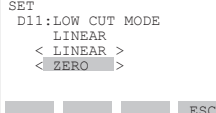

Press the  (OK) key.

Next, the [D11: LOW CUT MODE] setting panel is displayed.



Use the  or  key to select “ZERO.”

Press the  key twice to enter the setting.

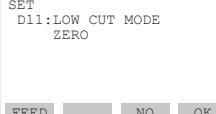

Press the  (OK) key.

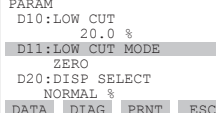

F0719.ai

**(6) Change Output Limits
(D15: OUT LIMIT(L), D16: OUT LIMIT(H))**



The range of normal output is preset at factory from -5.0 to 110.0% unless otherwise specified, and the output is limited with these upper and lower values. This output range can be changed, for example, to meet the requirements of NAMUR, etc. within the settable range. Set the lower limit with **D15:OUT LIMIT(L)** and upper limit with **D16:OUT LIMIT(H)**.

Settable range: -5.0 to 110.0 (%)

Lower limit < Upper limit

(7) Integral Indicator Scale Setup

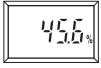
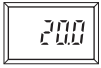
The following 5 displays are available for integral indicators.

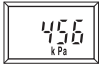
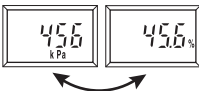
D20: DISP SELECT and Display	Description and Related parameters
<p>NORMAL %</p> 	<p>Indicates -5 to 110% range depending on the Measurement range (C21, C22).</p> <p>A10:OUTPUT (%) 45.6 %</p>
<p>USER SET</p> 	<p>Indicates values depending on the Engineering range (D22, D23).(Note 1) Units set using Engineering unit (D21) are not indicated.</p> <p>A11:ENGR.OUTPUT 20.0 M</p>
<p>USER & %</p> 	<p>Indicates user set and % alternately in 3 second intervals.</p> <p>A10:OUTPUT (%) 45.6 % A11:ENGR. OUTPUT 20.0 M</p>
<p>INP PRES</p> 	<p>Indicates input pressure.(Note 2) Indication limits -19999 to 19999.</p> <p>A40:INPUT 456 kPa</p>
<p>PRES & %</p> 	<p>Indicates input pressure and % alternately in 3 second intervals.</p> <p>A10:OUTPUT (%) 45.6 % A40:INPUT 456 kPa</p>

F0720.ai

Note 1: Scale range can be specified with range limit specifications up to 5 digits (excluding any decimal point) for low or high range limits within the range of -19999 to 19999. The range with decimals is available to the third decimal place.

Note 2: It indicates the value after zeroing.

See (a.) through (c.) for each setting procedure.

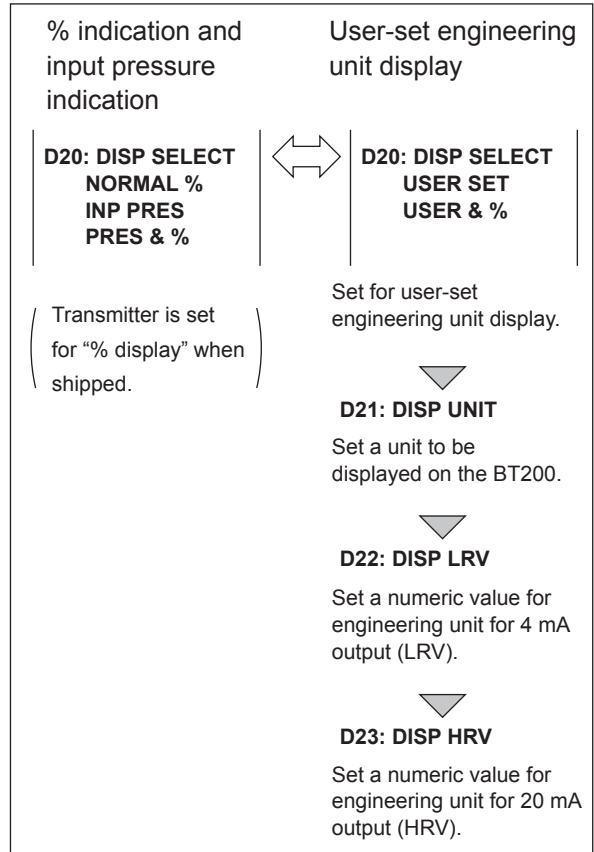

F0721.ai

a. Display Selection (D20: DISP SELECT)

Follow the instructions given to the below to change the range of integral indication scales.

When **USER SET** is selected, the user set values of integral indication and **A11: ENGR. OUTPUT** parameter are indicated.

• Example: Set the integral indicator scale to engineering units display.

```
SET
D20:DISP SELECT
NORMAL %
<NORMAL %>
<USER SET>
<USER & %>
<INP PRES>
```

Use the or key to select "USER SET."

Press the key twice to enter the setting.

```
SET
D20:DISP SELECT
USER SET
```

Press the (OK) key.

(The "%" disappears from the integral indicator display.)

F0722.ai

b. Setting User-set Engineering Unit (D21: DISP UNIT)

This parameter allows entry of the engineering units to be displayed on the BT200. When the instrument is shipped, this is set as specified in the order.

Follow the procedure below to change this setting.

This parameter need not be set for % display.

• Example: Set an engineering unit **M**.

```
SET
D21:DISP UNIT
M
```

Set "M."

Press the key twice to enter the setting.

```
SET
D21:DISP UNIT
M
```

Press the (OK) key.

F0723.ai

c. Lower and Higher Range Value Setup in Engineering Unit (D22: DISP LRV, D23: DISP HRV)

These parameter items are used to set the lower and higher range values for the engineering unit display.

When the instrument is shipped, these are set as specified in the order. Follow the procedure below to change these settings. Note that these parameters need not be set for % display.

• Example: Set lower range value (LRV) to **-50** and higher range value (HRV) to **50**.

```
Setting LRV
SET
D22:DISP LRV
0M
-50
```

Set "-50."

Press the key twice to enter the setting.

```
Setting HRV
SET
D23:DISP HRV
100M
50
```

Set "50."

Press the key twice to enter the setting.

```
SET
D23:DISP HRV
50M
```

Press the (OK) key.

```
PARAM
D21:DISP UNIT
M
D22:DISP LRV
50M
D23:DISP HRV
50M
```

F0724.ai

(8) Unit Setup for Displayed Temperature (D30: TEMP UNIT)

When the instrument is shipped, the temperature units are set to **degC**. Follow the procedure below to change this setting. Note that changing the unit here changes the unit for **A20: AMP TEMP** (amplifier temperature) and **A21: CAPSULE TEMP** (capsule temperature).

• Example: Change the unit for the temperature display.

```
SET
D30:TEMP UNIT
deg C
<deg C >
<deg F >
```

Use the or key to select "deg F."

Press the key twice to enter the setting.

F0725.ai

(9) Unit Setup for Displayed Static Pressure (D31: STAT.P.UNIT)



Follow the procedure below to change the static pressure units.

Changing this parameter changes the unit for the **A30: STATIC PRESS** (static pressure) display.

• Example: Change the static pressure unit from kgf/cm² to MPa.

```

SET
D31:STAT.P.UNIT
kgf/cm^2
< MPa >
< mbar >
< bar >
< gf/cm^2 >
ESC
    
```

Use the  or  key to select "MPa."

Press the  key twice to enter the setting.

```

mmH2O
mmAq
mmWG
mmHg
Torr
kPa
MPa
mbar
bar
gf/cm^2
kgf/cm^2
inH2O
inHg
ftH2O
psi
atm
Pa
hPa
    
```

F0726.ai



(10) Operation Mode Setup (D40: REV OUTPUT)

This parameter allows the direction of the 4 to 20 mA output to be reversed with respect to input. Follow the procedure below to make this change.

• Example: Change 4 to 20 mA output to 20 to 4 mA output.

```

SET
D40:REV OUTPUT
NORMAL
< NORMAL >
< REVERSE >
ESC
    
```

Use the  or  key to select REVERSE.

Press the  key twice to enter the setting.

F0727.ai



(11) Impulse Line Connection Orientation Setup (D45: H/L SWAP)

This parameter allows the impulse line connections to be reversed at the transmitter. Follow the figure below to make this change.

• Example: Change the impulse line connection from high pressure on right to high pressure on left.

```

SET
D45:H/L SWAP
NORMAL
< NORMAL >
< REVERSE >
ESC
    
```

Use the  or  key to select REVERSE.

Press the  key twice to enter the setting.

F0728.ai

(12) Output Status Display/Setup when a CPU Failure (D52: BURN OUT)

This parameter displays the status of 4 to 20 mA DC output if a CPU failure occurs. In case of a failure, communication is disabled.

Setting of HIGH or LOW is enabled. This is done with the pin (CN4) on the CPU assembly. See Chapter 3 for details.

Standard specifications

The parameter is set to HIGH. If a failure, the transmitter outputs the signal of 110% or higher. The parameter **D53: ERROR OUT** is set to HIGH from the factory.

Optional code/C1

The parameter is set to LOW. If a failure, output which is -5%*1 or lower is generated. The parameter **D53: ERROR OUT** is set to LOW from the factory.

*1: When optional code /F1 is specified, substitute the value with -5 with -2.5.

• Example: Standard specifications

```

D52: BURN OUT
HIGH
    
```

pin (CN4) position: H

• Example: Optional code/C1

```

D52: BURN OUT
LOW
    
```

pin (CN4) position: L

F0729.ai

(13) Output Status Setup when a Hardware Error Occurs (D53: ERROR OUT)

This parameter allows the setting of the output status when a hardware error occurs. The following three selections are available.

- (a) HOLD; Outputs the last value held before the error occurred.
- (b) HIGH; Outputs an output of 110% when an error has occurred.
- (c) LOW; Outputs an output of -5%*1 when an error has occurred.

Note: A hardware error means CAP MODULE FAULT of Er.01 or AMP MODULE FAULT of Er. 02 which are shown in 7.5.2 "Errors and Countermeasures.")

*1: When optional code /F1 is specified, substitute the value with -5 with -2.5.

• Example: Set the output status to LOW when a hardware error occurs.

```

SET
D53:ERROR OUT
  HIGH
  HIGH>
  < LOW>
  < HOLD>
  ESC

```

Use the or key to select "LOW."

Press the key twice to enter the setting.

F0730.ai

(14) Bi-directional Flow Measurement Setup (E30: BI DIRE MODE)

- (a) This parameter enables selection of 50% output at an input of 0 kPa. Procedure is shown in the figure below.
- (b) Combining this with **C40: OUTPUT MODE** provides a square root output computed independently for 0% to 50% output and for 50% to 100% output.

• Example: If measurement range is 0 to 10 kPa (LRV=0 kPa, HRV=10 kPa)

```

SET
E30:BI DIRE MODE
  OFF
  < OFF >
  < ON >
  ESC

```

Use the or key to select "ON."

Press the key twice to enter the setting.

The measurement range changes to -10 to 0 to 10 kPa (output 0% to 50% to 100%).

Note that "C21: LOW RANGE" and "C22: HIGH RANGE" are not changed.

F0731.ai

• Output mode "LINEAR"

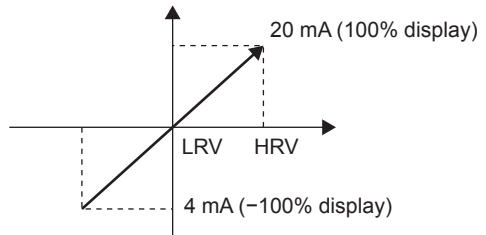

• Output mode "SQUARE ROOT"

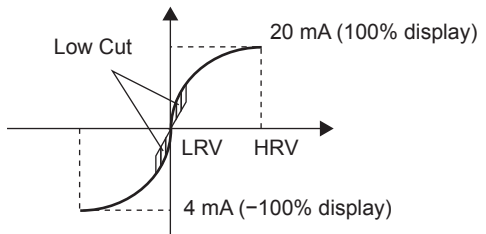

F0732.ai

(15) Range Change while Applying Actual Inputs
(H10: AUTO LRV, H11: AUTO HRV)

This feature allows the lower and higher range values to be set up automatically with the actual input applied. If the lower and higher range values are set, **C21: LOW RANGE** and **C22: HIGH RANGE** are changed at this same time.

Follow the procedure in the figure below. The measurement span is determined by the higher and lower range values. Changing the lower range value results in the higher range value changing auto-matically, keeping the span constant.

- Example 1: When changing the lower range value to 0.5 kPa for the present setting of 0 to 30 kPa, take the following action with input pressure of 0.5 kPa applied.

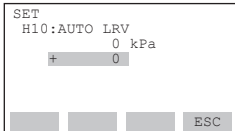

Press the **ENTER** key twice.
The lower range value is changed to 0.5 kPa.

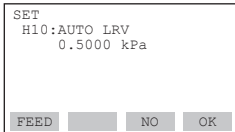

Press the **F4** (OK) key.

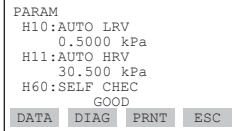

The higher range value is changed keeping the span constant.
Parameters **C21** and **C22** are changed at the same time.

F0733.ai

Note that changing the higher range value does not cause the lower range value to change but does change the span.

- Example 2: When the higher range value is to be changed to 10 kPa with the present setting of 0 to 30 kPa, take the following action with an input pressure of 10 kPa applied.

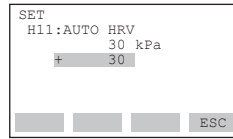

Press the **ENTER** key twice.
The higher range value is changed to 10 kPa.

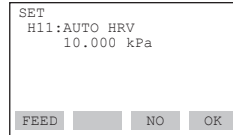

Press the **F4** (OK) key.

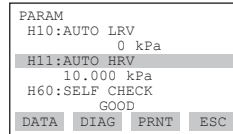

The lower range value is not changed, so the span changes.
Parameter **C22** is changed at the same time.

F0734.ai

(16) Zero Point Adjustment
(J10: ZERO ADJ, J11: ZERO DEV, J20: EXT ZERO ADJ)

The DPharp supports several adjustment methods.

Select the method best suited for the conditions of your application.

Note that output signal can be checked by displaying parameter **A10:OUTPUT (%)** on the BT200.

Adjustment Method	Description
Using the BT200	Set the present input to 0%. Adjust for 0% output at input level of 0%.
	Adjust output to the reference value obtained using other means. If the input level cannot easily be made 0% (because of tank level, etc.), adjust output to the reference value obtained using other means, such as a sight glass.
Using the external zero-adjustment screw	Adjust zero point using the zero-adjustment screw on the transmitter. This permits zero adjustment without using the BT200. Accurately adjust the output current to 4 mA DC or other target output value using an ammeter that accurately reads output currents.

(a) Follow the procedure below when setting the present output to 0% (4 mA).

A10:OUTPUT (%)
0.5 %

Output is 0.5%.

SET
J10:ZERO ADJ
0.0 %
+ 000.0

Press the ENTER key twice.

SET
J10:ZERO ADJ
0.0 %

Zero adjustment is completed.
Press the F4 (OK) key.

A10:OUTPUT (%)
0.0 %

Output is 0%.

F0735.ai

(b) In tank level measurement, if the actual level cannot be brought to zero for zero adjustment, then the output can be adjusted to correspond to the actual level obtained using another measuring instrument such as a glass gauge.

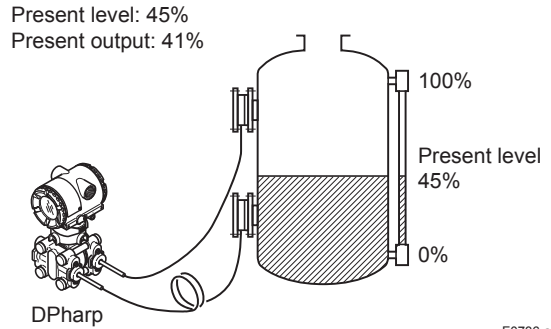

(b)-1 Follow the procedure below to use **J10: ZERO ADJ.**

A10:OUTPUT (%)
41.0 %

Present output is 41.0%.

SET
J10:ZERO ADJ
0.0 %
+ 040.0

Enter the present actual level, 40%.
Press the ENTER key twice.

A10:OUTPUT (%)
40.0 %

The output is changed to 40%.

F0737.ai

(b)-2 Follow the procedure below to use **J11: ZERO DEV.**

A10:OUTPUT (%)
41.0 %

Present output is 41.0%.
Output error = 45.0 – 41.0 = 4.0%.

SET
J11:ZERO DEV.
2.50 %
0

Since “J11: ZERO DEV.” contains the previous correction, obtain the correction value by adding 4.0% to it. (2.50% + 4.0% = 6.50%)

SET
J11:ZERO DEV.
2.50 %
6.50

Set the correction value, 6.50.
Press the ENTER key twice.

A10:OUTPUT (%)
45.0 %

The output is changed to 45%.

F0738.ai

When the zero point is adjusted, the displayed value of A40 is as follows.

[Example]

When the zero point is shifted by 20 kPa for the actual pressure, the parameter of A40 indicates 50 kPa.

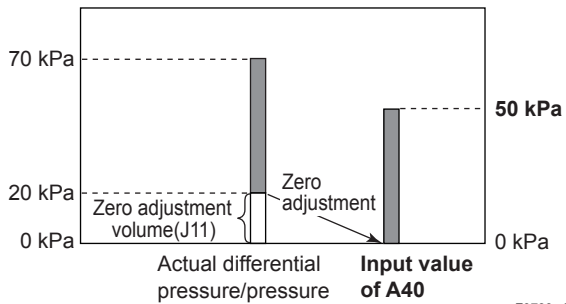

F0739.ai

(c) Zero Point Adjustment Using the External Zero Adjustment Screw

- Enabling/inhibiting of zero point adjustment using the external zero-adjustment screw on the transmitter (J20: EXT ZERO ADJ)

Follow the procedure below to enable or inhibit zero point adjustment from the zero-adjustment screw on the transmitter.

This is set to “ENABLE” when the instrument is shipped.

• Example: Inhibiting zero adjustment by the external zero-adjustment screw

```

SET
J20:EXIT ZERO ADJ
ENABLE
< ENABLE >
< INHIBIT >
                    
```

Use the or key to select “INHIBIT.”

Press the key twice to enter the setting.

F0740.ai

- Zero point adjustment using external zero-adjustment screw on the transmitter

Turn the zero-adjustment screw on the outside of the transmitter case using a slotted screwdriver. Turn the screw to the right to increase the zero point or to the left to decrease the zero output; the zero adjusts in increments of 0.01% of the range setting. Note that the amount of adjustment to the zero point changes according to the speed at which the screw is turned. To make fine adjustments, turn the screw slowly; to make coarse adjustments, turn the screw quickly.

Note: When a zero point adjustment has been made, do not turn off the transmitter less than 30 seconds after adjustment.

(17) Span Adjustment

Each DPharp EJA series transmitter is factory characterized according to the specification. Mounting position effects or zero shifts caused by static pressure are typically compensated by a zero adjustment.

A span adjustment is a function to correct the slope error from a zero point in characterizing 100% point (HRV). This function can be used when span drifts may be caused or characterization to the specific pressure standard is required.

Therefore, the zero point adjustment should always be performed before the upper point adjustment in order to maintain the pitch between zero and 100% points within the calibration range.

You can manually perform the trimming procedure by using J15: SPAN ADJ.

- Span adjustment value
The span adjustment value is calculated as follows.

$$\text{Span adjustment value (\%)} = \frac{P_1 - A40}{P_1} \times 100$$

P_1 : Actual differential pressure/pressure value

A40: Input (indicated as the value after zeroing)

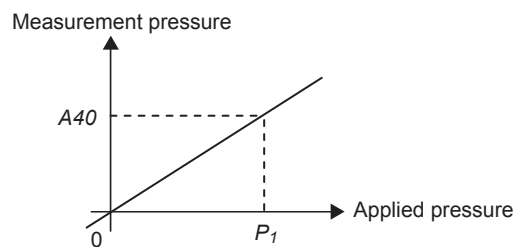

F0741.ai

- Example: For the range of 0 to 30 kPa.
A40: INPUT = 30.15 kPa
J15: SPAN ADJ = 0.15 %

Suppose that a standard pressure of 30 kPa is applied and the value of the parameter of A40:INPUT is 30.15 kPa. Firstly, obtain the slope error for the span as follows;

$$\begin{aligned} \text{Span adjustment value (\%)} &= \frac{P_1 - A40}{P_1} \times 100 \\ &= \frac{30.00 - 30.15}{30.00} \times 100 = -0.5 (\%) \end{aligned}$$

Add -0.5% to 0.15% of the current value to calculate the accumulated span adjustment value.

$$0.15 + (-0.50) = -0.35$$

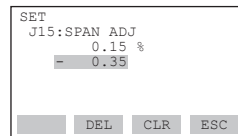

Set **-0.35**.
Press the **ENTER** key twice.

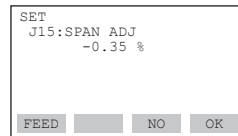

Press the **F4** (OK) key.

Note: Enter 0.00 to J15: SPAN ADJ to reset the span adjustment to the initial value at the shipment.

F0742.ai

(18) Test Output Setup (K10: OUTPUT X%)

This feature can be used to output a fixed current from 3.2 mA (-5%) to 21.6 mA (110%) for loop checks.

- Example: Output 12 mA (50%) fixed current.

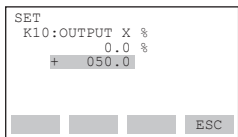

Set "50.0%."
Press the **ENTER** key twice to output a fixed current at 50%.

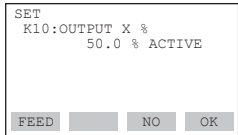

"Active" is displayed while this is being executed.
Press the **F4** (OK) key to cancel the fixed current output.

F0743.ai

Note: When optional code /F1 is specified, output range is from 3.6mA(-2.5%) to 21.6mA(110%).



IMPORTANT

- Test output is held for approximately 10 minutes, and then released automatically after the time has elapsed. Even if the BT200 power supply is turned off or the communication cable is disconnected during test output, it is held for approximately 10 minutes.
- Press the [F4] (OK) key to release test output immediately.

(19) Ambient Temperature Zero Shift Compensation

This function is used to compensate the zero shift by the ambient temperature effect on the capillary tubes.

- (1) DFS Mode Setup (E10: DFS MODE) When using the function, set the DFS MODE to "ON" to enable or "OFF" to disable. To set to "ON", follow the procedure at right.

- Set the DFS mode to "ON".

Use the **▲** or **▼** key to select "ON".
Press the **ENTER** key twice to enter the setting.
Press the **F4** (OK) key.

F0744.ai

- (2) Reference Temperature Sensor Setup (E14: TEMP SELECT) "CAP.TEMP" is selected for use. Follow the procedure at right.

- Set the TEMP SELECT to "CAP.TEMP".

Use the **▲** or **▼** key to select "CAP.TEMP".
Press the **ENTER** key twice to enter the setting.
Press the **F4** (OK) key.

F0745.ai

- (3) Zero Shift Compensation Setup (E15:TEMP ZERO) Obtain the compensation value of K from the equation(1) below. Then enter the value to execute. The value can be rounded off to two decimal places.

$$K = - \frac{h \times B}{\text{Span}} \times 100 \text{ ----- (1)}$$

where,

h: Distance from high side of diaphragm seal to low side of diaphragm seal(m).

B: Constant value of fill fluid (see Table A. below)

span:|HRV-LRV|

Example:When h=+3m,fill fluid code A, and span=15kPa,

$$K = - \frac{(+3) \times 0.00745}{15} \times 100 = -0.15$$

- Enter the value of K obtained from the equation(1)

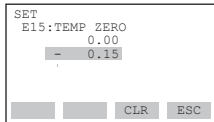

Enter “-0.15.”
Press the **ENTER** key twice to enter the setting.
Press the **F4** (OK) key.

F0746.ai

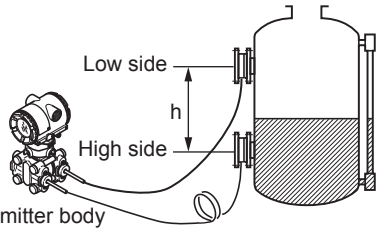

F0747.ai

- Note 1: The function is engaged in a built-in temperature sensor in the transmitter body. The temperature deviation between the transmitter body and capillaries should be minimized to achieve optimal performance of the function.
- Note2: When the span changes, reenter the newly obtained value of K to E15:TEMP ZERO.

Table A. Constant value[B] of fill Fluid

	Fill fluid code	A, C	B	D	E
Constant value [B]	mmH ₂ O	0.76	0.87	1.45	0.75
	kgf/cm ²	0.000076	0.000087	0.000145	0.000075
	KPa	0.00745	0.00853	0.01422	0.00736
	mBar	0.07453	0.08532	0.14220	0.07355
	atm	0.000074	0.000084	0.000140	0.000073
	inH ₂ O	0.02992	0.03425	0.05709	0.02953
	psi	0.00108	0.00124	0.00206	0.00167
	mmHg	0.05592	0.06401	0.10669	0.05518

Note: select the constant value of[B] from the actual unit used shown in the table.

(20) User Memo Fields (M: MEMO)

This feature provides 5 user memo fields, each holding up to 8 alphanumeric characters. Up to 5 items such as inspection date, inspector, and other information can be saved in these fields.

- Example: Save an inspection date of January 30, 1995.

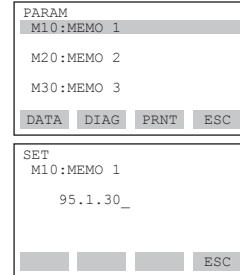

Set “95.1.30” in the order of year, month, and day.
Press the **ENTER** key twice to enter the setting.

F0748.ai

7.4 Displaying Data Using the BT200

7.4.1 Displaying Measured Data

The BT200 can be used to display measured data.

The measured data is updated automatically every 7 seconds. In addition, the display can be updated to the present data value at any time by pressing the [F1] (DATA) key. For parameters associated with the display of measured data, see Subsection 7.3.1, "Parameter Summary."

• Example: Display output.

Display "A10: OUTPUT (%)."

Data is updated automatically at 7-second intervals.

F0749.ai

7.4.2 Display Transmitter Model and Specifications

The BT200 can be used to display the model and specifications of the transmitter.

• Example: View transmitter model name.

Press **ENTER**.

For the associated parameters, see Subsection 7.3.1, Parameter Summary.

F0750.ai

7.5 Self-Diagnostics

7.5.1 Checking for Problems

(1) Identifying Problems with BT200

The following four areas can be checked.

- Whether connections are good.
- Whether BT200 was properly operated.
- Whether settings were properly entered.
- History of the errors.

See examples below.

• Example 1: Connection errors

Press the **ON/OFF** key.

When the panel shown on the left appears, press the **ENTER** key.

Since communications will be unsuccessful if there is a problem in the connection to the BT200, the display at the left will appear.

Recheck the connection.

Press the **F4** (OK) key.

F0751.ai

• Example 2: Setting entry errors

The initial data panel shows the result of current transmitter diagnostics.

Press the **F2** (DIAG) key in the parameter panel to go to the diagnostics panel (C60: SELF CHECK).

An error message is displayed when an error occurs in the diagnostics panel.

F0752.ai

• Example 3: Checking the history of the errors

```
MENU
J:ADJUST
K:TEST
M:MEMO
P:RECORD
HOME SET ADJ ESC
```

Connect the BT200 to the transmitter, and call item "P."

```
PARAM
P10:ERROR REC 1
      ERROR
P11:ERROR REC 2
      ERROR
P12:ERROR REC 3
      GOOD
DATA DIAG PRNT ESC
```

- P10: "ERROR REC 1" displays the last error.
- P11: "ERROR REC 2" displays the error one time before the last error occurred.
- P12: "ERROR REC 3" displays the error two times before the last error occurred.
- P13: "ERROR REC 4" displays the error three times before the last error occurred.

The history of up to four errors can be stored. When the 5th error has occurred, it is stored in "P10". The error stored in "P13" will be deleted, and then, the error in "P12" will be copied to "P13". In this sequence, the history of the most previously occurred error will be removed from memory.

"GOOD" will be displayed if there was no previous error.

```
SET
P10:ERROR REC 1
      ERROR
      < ERROR >
      < ILLEGAL LRV >
      < ILLEGAL HRV >
ESC
```

Select P10: ERROR REC1 and press the **ENTER** key to display the error message.

<(a) SETUP PANEL>

For the details of the messages listed below, see Table 7.2 Error Message Summary.

CAP MODULE FAULT	OVER TEMP (CAP)	ILLEGAL LRV
AMP MODULE FAULT	OVER TEMP (AMP)	ILLEGAL HRV
OUT OF RANGE	OVER OUTPUT	ILLEGAL SPAN
OUT OF SP RANGE	OVER DISPLAY	ZERO ADJ OVER

Note 1: Press the **ENTER** key twice in the setting panel (panel 1) to clear all error message (P10 to P13) information.

Note 2: After two hours from when an error occurs, the error message of that error will be recorded. Therefore, if you switch off the transmitter within two hours from when the error occurs, there is no history of that error stored in the transmitter, and this function is meaningless.

F0753.ai

(2) Checking with Integral Indicator



NOTE

If an error is detected in the self-diagnostic, an error number is displayed on the integral indicator. If there is more than one error, the error number changes at two-second intervals. See Table 7.2 regarding the error numbers.



F0754.ai

Figure 7.5 Identifying Problems Using the Integral Indicator

7.5.2 Errors and Countermeasures

The table below shows a summary of error messages.

Table 7.2 Error Message Summary

Integral Indicator Display	BT200 Display	Cause	Output Operation during Error	Countermeasure
None	GOOD			
---	ERROR			
Er.01	CAP MODULE FAULT	Capsule problem.*1	Outputs the signal (Hold, High, or Low) set with parameter D53.	Replace the capsule when error keeps appearing even after restart.*2
Er.02	AMP MODULE FAULT	Amplifier problem.	Outputs the signal (Hold, High, or Low) set with parameter D53.	Replace amplifier.
Er.03	OUT OF RANGE	Input is outside measurement range limit of capsule.	Outputs high range limit value or low range limit value.	Check input.
Er.04	OUT OF SP RANGE	Static pressure exceeds specified range.*3	Displays present output.	Check line pressure (static pressure).
Er.05	OVER TEMP (CAP)	Capsule temperature is outside range (-50 to 130°C).	Displays present output.	Use heat insulation or make lagging to keep temperature within range.
Er.06	OVER TEMP (AMP)	Amplifier temperature is outside range (-50 to 95°C).	Displays present output.	Use heat insulation or make lagging to keep temperature within range.
Er.07	OVER OUTPUT	Output is outside high or low range limit value.	Outputs high or low range limit value.	Check input and range setting, and change them as needed.
Er.08	OVER DISPLAY	Displayed value is outside high or low range limit value.	Displays high or low range limit value.	Check input and display conditions and modify them as needed.
Er.09	ILLEGAL LRV	LRV is outside setting range.	Holds output immediately before error occurrence.	Check LRV and modify as needed.
Er.10	ILLEGAL HRV	HRV is outside setting range.	Holds output immediately before error occurrence.	Check HRV and modify as needed.
Er.11	ILLEGAL SPAN	SPAN is outside setting range.	Holds output immediately before error occurrence.	Check SPAN and change as needed.
Er.12	ZERO ADJ OVER	Zero adjustment is too large.	Displays present output.	Readjust zero point

*1: This error code appears at a capsule problem or when an illegal overpressure is applied to the pressure sensor.

*2: If the normal pressure is regained, the Er.01 will disappear according to the setting of the parameter of E50: AUTO RECOVER. When the E50: AUTO RECOVER is set to ON (default setting), the Er.01 will disappear automatically. When the E50: AUTO RECOVER is set to OFF, restart the transmitter to cancel Er.01. If no error code appears then, perform necessary adjustment such as zero-adjustment to continue the operation. If the error code still exists, replace the capsule assembly.

*3: For Model EJA120A, static pressure cannot be measured. The display is always 0 MPa, but this is not a measured value.

8. Maintenance

8.1 Overview



WARNING

Since the accumulated process fluid may be toxic or otherwise harmful, take appropriate care to avoid contact with the body, or inhalation of vapors during draining condensate or venting gas in transmitter pressure-detector section even after dismantling the instrument from process line for maintenance.

Maintenance of the transmitter is easy due to its modular construction. This chapter describes the procedures for calibration, adjustment, and the disassembly and reassembly procedures required for component replacement.

Since the transmitters are precision instruments, carefully and thoroughly read the following sections for proper handling during maintenance.



IMPORTANT

- As a rule, maintenance of this transmitter should be implemented in a maintenance service shop where the necessary tools are provided.
- The CPU assembly contains sensitive parts that may be damaged by static electricity. Exercise care so as not to directly touch the electronic parts or circuit patterns on the board, for example, by preventing static electrification by using grounded wrist straps when handling the assembly. Also take precautions such as placing a removed CPU assembly into a bag with an antistatic coating.

8.2 Calibration Instruments Selection

Table 8.1 shows the instruments required for calibration. Select instruments that will enable the transmitter to be calibrated or adjusted to the required accuracy.

The calibration instruments should be handled carefully so as to maintain the specified accuracy.

8.3 Calibration

Use the procedure below to check instrument operation and accuracy during periodic maintenance or troubleshooting.

- 1) Connect the instruments as shown in Figure 8.1 and warm up the instruments for at least five minutes.



IMPORTANT

- To adjust the transmitter for highest accuracy, make adjustments with the power supply voltage and load resistance including leadwire resistances set close to the conditions under which the transmitter is installed.
- If the measurement range 0% point is 0 kPa or shifted in the positive direction (suppressed zero), the reference pressure (suppressed zero) should be applied on the high pressure side, as shown in the figure (low pressure side open to atmosphere). If the measurement range 0% point is shifted in the negative direction (elevated zero), the reference pressure should be applied on the low pressure side.
- Do not perform the calibration procedure until the transmitter is at room temperature.

- 2) Apply reference pressures of 0%, 50%, and 100% of the measurement range to the transmitter. Calculate the errors (differences between digital voltmeter readings and reference pressures) as the pressure is increased from 0% to 100% and is decreased from 100% to 0%, and confirm that the errors are within the required accuracy.

Note: When the output mode is set to SQRT, apply reference pressures of 0, 6.25, 25, 56.25 and 100%, instead.

Table 8.1 Instruments Required for Calibration

Name	Yokogawa-recommended Instrument	Remarks
Power supply	Model SDBT or SDBS distributor	4 to 20 mA DC signal
Load resistor	Model 2792 standard resistor [250 Ω ±0.005%, 3 W] Load adjustment resistor [100 Ω ±1%, 1 W]	
Voltmeter	Model 2501 A digital multimeter Accuracy (10V DC range): ±(0.002% of rdg + 1 dgt)	
Digital manometer	Model MT220 precision digital manometer 1) For 10 kPa class Accuracy: ± (0.015% of rdg + 0.015% of F.S.) ··· for 0 to 10 kPa ± (0.2% of rdg + 0.1% of F.S.) ····· for -10 to 0 kPa 2) For 130 kPa class Accuracy: ± 0.02% of rdg ··········· for 25 to 130 kPa ± 5 digits ··········· for 0 to 25 kPa ± (0.2% of rdg + 0.1% of F.S.) ····· for -80 to 0 kPa 3) For 700 kPa class Accuracy: ± (0.02% of rdg + 3 digits) ········· for 100 to 700 kPa ± 5 digits ··········· for 0 to 100 kPa ± (0.2% of rdg + 0.1% of F.S.) ····· for -80 to 0 kPa 4) For 3000 kPa class Accuracy: ± (0.02% of rdg + 10 digits) ······· for 0 to 3000 kPa ± (0.2% of rdg + 0.1% of F.S.) ····· for -80 to 0 kPa 5) For 130 kPa abs class Accuracy: ± (0.03% of rdg + 6 digits) ······· for 0 to 130 kPa abs	Select a manometer having a pressure range close to that of the transmitter.
Pressure generator	Model 7674 pneumatic pressure standard for 200 kPa {2 kgf/cm ² }, 25 kPa {2500 mmH ₂ O} Accuracy: ± 0.05% of F.S.	Requires air pressure supply.
	Dead weight gauge tester 25 kPa {2500 mmH ₂ O} Accuracy: ±0.03% of setting	Select a pressure generator having a pressure range close to that of the transmitter.
Pressure source	Model 6919 pressure regulator (pressure pump) Pressure range: 0 to 133 kPa {1000 mmHg}	Prepare the vacuum pump for negative pressure ranges.

Note: The above table contains the instruments capable of performing calibration to the 0.2% level. Since special maintenance and management procedures involving traceability of each instrument to higher-level standards are required for calibration to the 0.1% level, there are difficulties in calibration to this level in the field. For calibration to the 0.1% level, contact Yokogawa representatives from which the instrument was purchased or the nearest Yokogawa office.

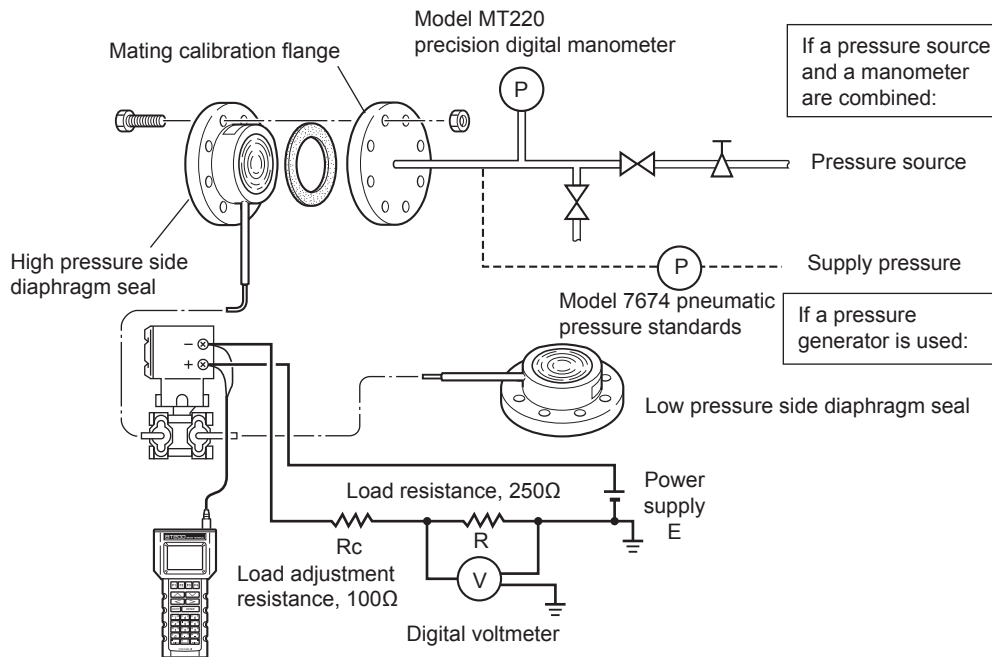

Figure 8.1 Instrument Connections

F0801.ai

8.4 Disassembly and Reassembly

This section describes procedures for disassembly and reassembly for maintenance and component replacement.

Always turn OFF power and shut off and release pressures before disassembly. Use proper tools for all operations. Table 8.2 shows the tools required.

Table 8.2 Tools for Disassembly and Reassembly

Tool	Quantity	Remarks
Phillips screwdriver	1	JIS B4633, No. 2
Slotted screwdriver	1	
Allen wrenches	2	JIS B4648 One each, nominal 3 and 5 mm Allen wrenches
Wrench	1	Width across flats, 17 mm
Torque wrench	1	
Adjustable wrench	1	
Socket wrench	1	Width across flats, 16 mm
Socket driver	1	Width across flats, 5.5 mm
Tweezers	1	

CAUTION

Precautions for CENELEC, IECEx and TlIS Flameproof Type Transmitters

- Flameproof type transmitters must be, as a rule, removed to a non-hazardous area for maintenance and be disassembled and reassembled to the original state.
- Two covers are locked by each of an Allen head bolt (shrouding bolt) on the flameproof type transmitters. When a shrouding bolt is driven clockwise by an Allen wrench, it is going in and cover lock is released, and then a cover can be opened.
When a cover is closed it should be locked by a shrouding bolt without fail. Tighten the shrouding bolt to a torque of 0.7 N·m.

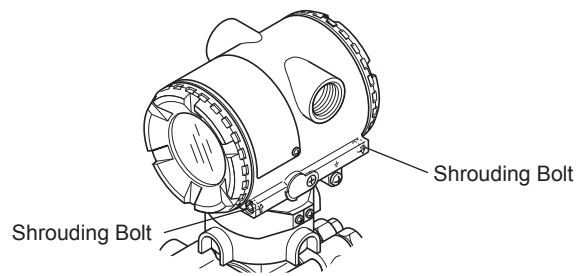

F0802.ai

Figure 8.2 Shrouding Bolts

8.4.1 Replacing the Integral Indicator

This subsection describes the procedure for replacing an integral indicator. (See Figure 8.4)

CAUTION

Precautions for TlIS Flameproof Type Transmitters

Users are prohibited by law from modifying the construction of a flameproof type transmitter. Thus the user is prohibited from using a flameproof type transmitter with its integral indicator removed, or from adding an integral indicator to a transmitter. If such modification is absolutely required, contact Yokogawa.

■ Removing the Integral Indicator

- Remove the cover.
- Supporting the integral indicator by hand, loosen its two mounting screws.
- Dismount the LCD board assembly from the CPU assembly.
When doing this, carefully pull the LCD board assembly straight forward so as not to damage the connector between it and the CPU assembly.

■ **Attaching the Integral Indicator**

Integral indicator can be installed in the following three directions.

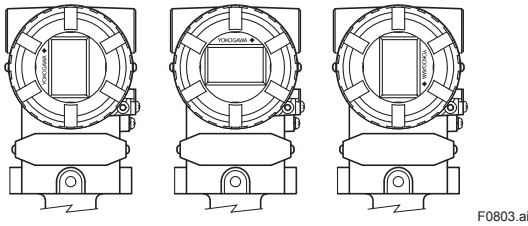

Figure 8.3 Installation Direction of Indicator

- 1) Align both the LCD board assembly and CPU assembly connectors and engage them.
- 2) Insert and tighten the two mounting screws.
- 3) Replace the cover.

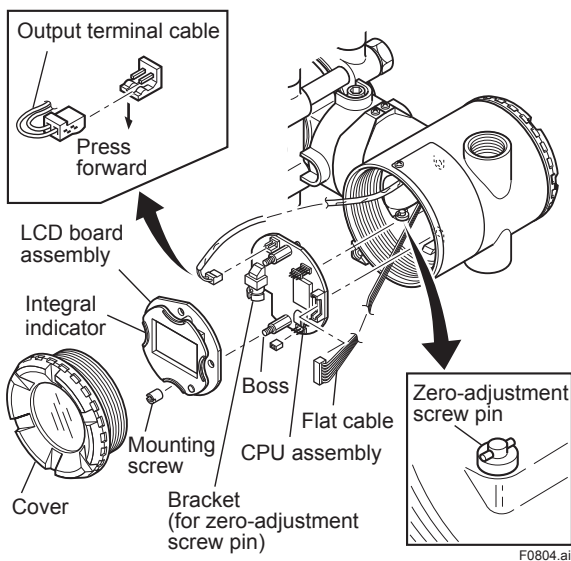

Figure 8.4 Removing and Attaching LCD Board Assembly and CPU Assembly

8.4.2 Replacing the CPU Assembly

This subsection describes the procedure for replacing the CPU assembly. (See Figure 8.4)

■ **Removing the CPU Assembly**

- 1) Remove the cover. If an integral indicator is mounted, refer to Subsection 8.4.1 and remove the indicator.
- 2) Turn the zero-adjustment screw to the position (where the screw head slot is horizontal) shown in Figure 8.4.

- 3) Disconnect the output terminal cable (cable with brown connector at the end). When doing this, lightly press the side of the CPU assembly connector and pull the cable connector to disengage.
- 4) Use a socket driver (width across flats, 5.5mm) to loosen the two bosses.
- 5) Carefully pull the CPU assembly straight forward to remove it.
- 6) Disconnect the flat cable (cable with black connector at the end) that connects the CPU assembly and the capsule.

 **NOTE**

Be careful not to apply excessive force to the CPU assembly when removing it.

■ **Mounting the CPU Assembly**

- 1) Connect the flat cable (with black connector) between the CPU assembly and the capsule.
- 2) Connect the output terminal cable (with brown connector).

 **NOTE**

Make certain that the cables are free of pinching between the case and the CPU assembly edge.

- 3) Align and engage the zero-adjustment screw pin with the groove on the bracket on the CPU assembly. Then insert the CPU board assembly straight onto the post in the amplifier case.
- 4) Tighten the two bosses. If the transmitter is equipped with an integral indicator, refer to Subsection 8.4.1 to mount the indicator.

 **NOTE**

Confirm that the zero-adjustment screw pin is placed properly in the groove on the bracket prior to tightening the two bosses. If it is not, the zero-adjustment mechanism will be damaged.

- 5) Replace the cover.

8.5 Troubleshooting

If any abnormality appears in the measured values, use the troubleshooting flow chart below to isolate and remedy the problem. Since some problems have complex causes, these flow charts may not identify all. If you have difficulty isolating or correcting a problem, contact Yokogawa service personnel.

8.5.1 Basic Troubleshooting

First determine whether the process variable is actually abnormal or a problem exists in the measurement system.

If the problem is in the measurement system, isolate the problem and decide what corrective action to take.

This transmitter is equipped with a self-diagnostic function which will be useful in troubleshooting; see Section 7.5 for information on using this function.

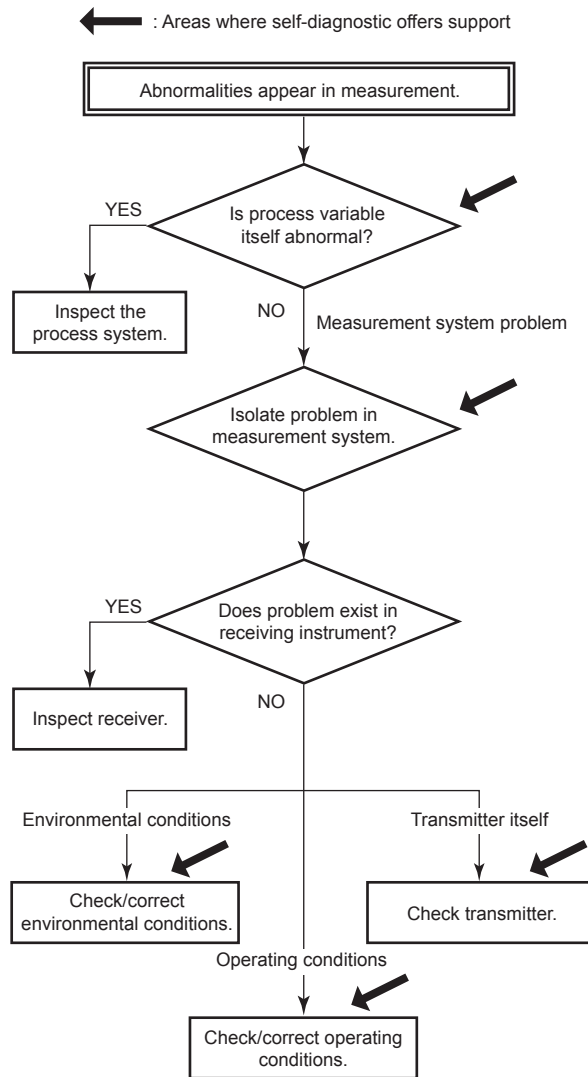

F0805.ai

Figure 8.5 Basic Flow and Self-Diagnostics

8.5.2 Troubleshooting Flow Charts

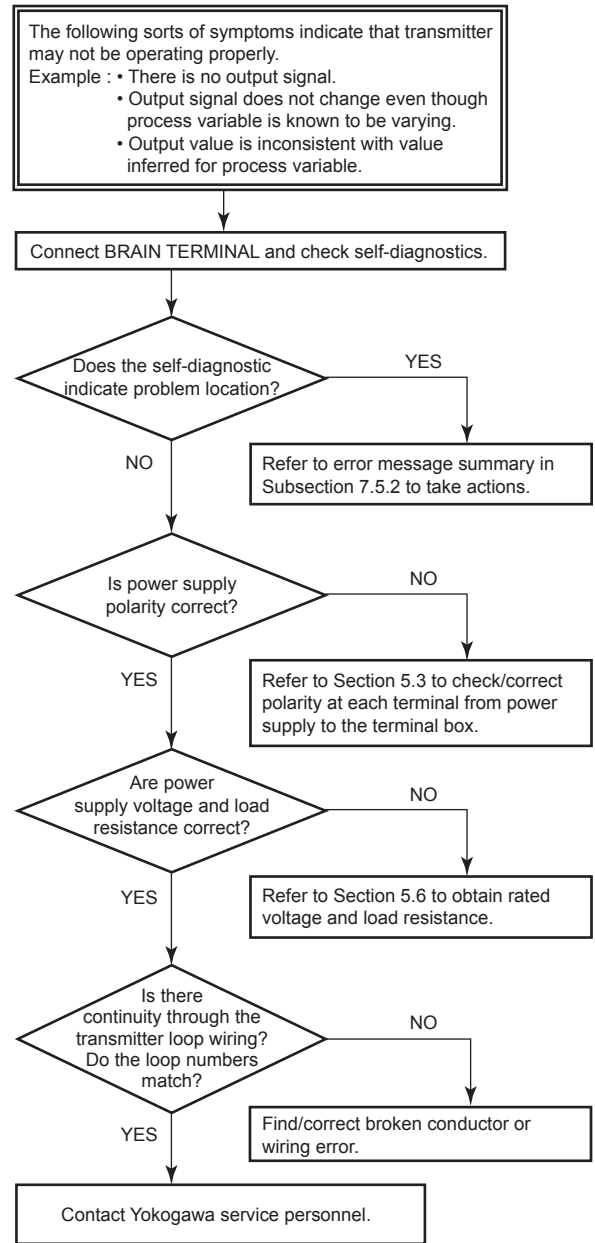

F0806.ai

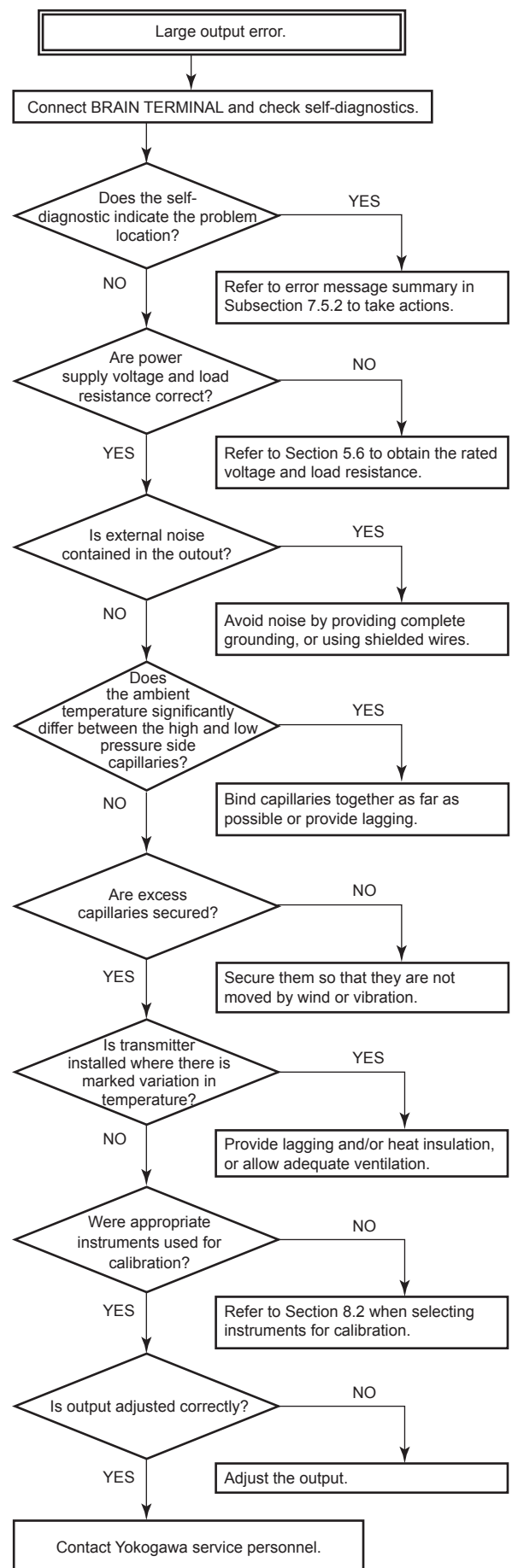
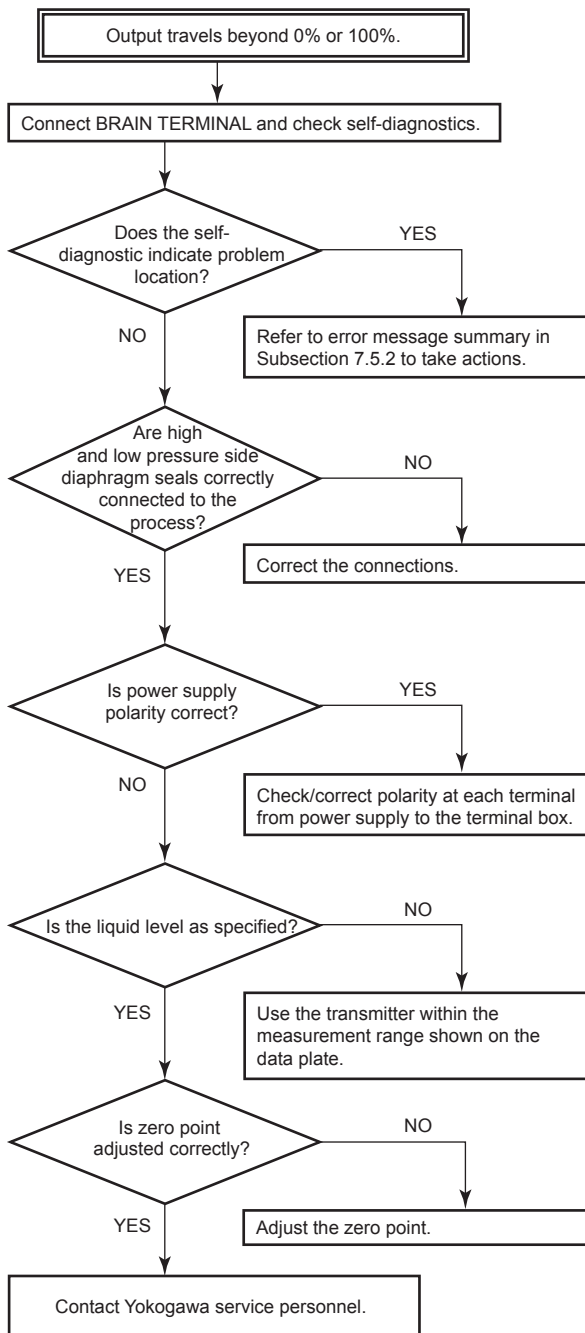

9. General Specifications

9.1 Standard Specifications

Refer to IM 01C22T02-01E for FOUNDATION Fieldbus communication type and IM 01C22T03-00E for PROFIBUS PA communication type marked with “◇”.

● Performance Specifications

See General Specifications sheet, GS 01C22H01-00E.

● Functional Specifications

Span & Range Limits

Measurement Span and Range		kPa	inH ₂ O (/D1)	mbar (/D3)	mmH ₂ O (/D4)
M	Span	2.5 to 100	10 to 400	25 to 1000	250 to 10000
	Range	-100 to 100	-400 to 400	-1000 to 1000	-10000 to 10000
H	Span	25 to 500	100 to 2000	250 to 5000	0.25 to 5 kgf/cm ²
	Range	-500 to 500	-2000 to 2000	-5000 to 5000	-5 to 5 kgf/cm ²

Measurement range is within the flange rating.

Zero Adjustment Limits:

Zero can be fully elevated or suppressed, within the Lower and Upper Range Limits of the capsule.

External Zero Adjustment “◇”:

External zero is continuously adjustable with 0.01% incremental resolution of span. Span may be adjusted locally using the digital indicator with range switch.

Output “◇”:

Two wire 4 to 20 mA DC output with digital communications, linear or square root programmable. BRAIN or HART FSK protocol are superimposed on the 4 to 20 mA signal.

Failure Alarm:

Output status at CPU failure and hardware error;

Up-scale:

110%, 21.6 mA DC or more(standard)

Down-scale:

-5%, 3.2 mA DC or less or -2.5%, 3.6 mA DC or less(Optional code /F1)

Note: Applicable for Output signal code D and E

Damping Time Constant (1st order):

The sum of the amplifier and capsule damping time constant must be used for the overall time constant. Amp damping time constant is adjustable from 0.2 to 64 seconds.

Capsule (Silicone Oil)	M	H
Time Constant (approx. sec)	0.5	0.5

When the capillary length 5 m and Fill fluid code A.

Ambient Temperature Limits:

* Safety approval codes may affect limits.

-40 to 60°C (-40 to 140°F)

-30 to 60°C (-22 to 140°F) with LCD Display

Note: The ambient temperature limits must be within the fill fluid operating temperature range, see Table 9.1.

Process Temperature Limits:

* Safety approval codes may affect limits.

See Table 9.1.

Working Pressure Range:

2.7 kPa {20 mmHg abs} to flange rating pressure.

For atmospheric pressure or below, see Figure 9.1.

● Installation

Supply & Load Requirements “◇”:

* Safety approvals can affect electrical requirements.

See Section 5.6, ‘Power Supply Voltage and Load Resistance.’

Supply Voltage “◇”:

10.5 to 42 V DC for general use and flameproof type

10.5 to 32 V DC for lightning protector (Optional code /A)

10.5 to 30 V DC for intrinsically safe, Type n, nonincendive, or non-sparking type

10.5 to 28 V DC for TIIS intrinsically safe type

EMC Conformity Standards:

EN 61326-1 Class A, Table 2 (For use in industrial locations)

EN 61326-2-3

EN 61326-2-5 (for Fieldbus)

Immunity influence during the test

Differential pressure/pressure: Output shift is specified within ±1% of 1/10 Max span.

Communication Requirements “◇”:**BRAIN****Communication Distance;**

Up to 2 km (1.25 miles) when using CEV polyethylene-insulated PVC-sheathed cables.

Communication distance varies depending on type of cable used.

Load Capacitance;

0.22 µF or less (see note)

Load Inductance;

3.3 mH or less (see note)

Input Impedance of communicating device;

10 kΩ or more at 2.4 kHz.

Note: For general-use and Flameproof type. For Intrinsically safe type, please refer to 'Optional Specifications.'

HART**Communication Distance;**

Up to 1.5 km (1 mile) when using multiple twisted pair cables. Communication distance varies depending on type of cable used.

Use the following formula to determine cable length for specific applications:

$$L = \frac{65 \times 10^6}{(R \times C)} - \frac{(C_f + 10,000)}{C}$$

Where:

L = length in meters or feet

R = resistance in Ω (including barrier resistance)

C = cable capacitance in pF/m or pF/ft

C_f = maximum shunt capacitance of receiving devices in pF/m or pF/ft

● Physical Specifications**Wetted Parts Materials:****Diaphragm and other wetted parts;**

See 'Model and Suffix Codes'

Non-wetted Parts Materials:**Capillary tube;**

SUS316

Protection tube;

SUS304, PVC-sheathed [Max. operating temperature: 100°C (212°F)]

Fill Fluid;

See Table 9.1.

Housing;

Low copper cast-aluminum alloy with polyurethane paint (Munsell 0.6GY3.1/2.0)

Degrees of Protection;

IP67, NEMA4X

Cover O-rings;

Buna-N, Fluoro-rubber (option)

Data plate and tag;

SUS304 or SUS316(option)

Weight:

21.7 kg (47.8 lb): Model EJA118W, 3-inch ANSI Class 150 flange, without mounting bracket.
Add 1.4 kg (3.1 lb) for JIS SCS14A stainless steel amplifier housing.

Connections:

Refer to the 'Model and Suffix Codes' to specify the process and electrical connection type.

Table 9.1 Process Temperature and Ambient Temperature

	Silicone Oil			Fluorinated Oil	Ethylene Glycol
	Fill Fluid Code 'A'	Fill Fluid Code 'B'	Fill Fluid Code 'C'	Fill Fluid Code 'D'	Fill Fluid Code 'E'
Process Temperature*1	-10 to 250°C (14 to 482°F)	-30 to 180°C (-22 to 356°F)	10 to 300°C (50 to 572°F)	-20 to 120°C (-4 to 248°F)	-50 to 100°C (-58 to 212°F)
Ambient temperature*2	-10 to 60°C (14 to 140°F)	-15 to 60°C (5 to 140°F)	10 to 60°C (50 to 140°F)	-10 to 60°C (-14 to 140°F)	-40 to 60°C (-40 to 140°F)
Working pressure	See Figure 9.1			51 kPa abs or more {380 mmHg abs}	Vacuum pressure not allowed
Specific gravity*3	1.07	0.94	1.09	1.90 to 1.92	1.09

- *1: See Figure 9.1 'Working Pressure and Process Temperature.'
- *2: This ambient temperature is the transmitter ambient temperature.
- *3: Approximate values at a temperature of 25°C(77°F)
- *4: The differential pressure transmitter should be installed at least 600 mm below the high pressure(HP) process connection. However, this value(600 mm) may be affected by ambient temperature, operating pressure, fill fluid or material of the wetted diaphragm. Contact YOKOGAWA when the transmitter can not be installed at least 600 mm below the HP process connection.

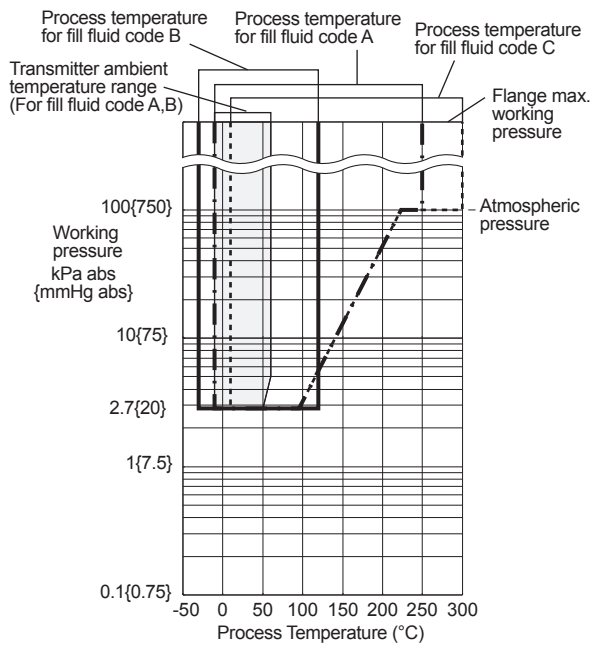

Figure 9.1 Working Pressure and Process Temperature

< Settings When Shipped > “◇”

Tag Number	As specified in order *1
Output Mode	'Linear' unless otherwise specified in order
Display Mode	'Linear' unless otherwise specified in order
Operation Mode	'Normal' unless otherwise specified in order
Damping Time Constant	'2 sec.'
Calibration Range Lower Range Value	As specified in order
Calibration Range Higher Range Value	As specified in order
Calibration Range Units	Selected from mmH2O, mmAq, mmWG, mmHg, Pa, hPa, kPa, MPa, mbar, bar, gf/cm ² , kgf/cm ² , inH2O, inHg, ftH2O, or psi. (Only one unit can be specified)

- *1: If Tag No. is no more than 16 alphanumeric characters (including - and .), it will be written into the tag plate and amplifier memory settings.

9.2 Model and Suffix Codes

● Model EJA118W

Model	Suffix Codes	Description
EJA118W	Diaphragm sealed differential pressure transmitter (Flush diaphragm type)
Output Signal	-D	4 to 20 mA DC with digital communication (BRAIN protocol)
	-E	4 to 20 mA DC with digital communication (HART protocol, see IM 01C22T01-01E)
	-F	Digital communication (FOUNDATION Fieldbus protocol, see IM 01C22T02-01E)
	-G	Digital communication (PROFIBUS PA protocol, see IM 01C22T03-00E)
Measurement span (capsule)	M	2.5 to 100 kPa {250 to 10000 mmH ₂ O}
	H	25 to 500 kPa {0.25 to 5 kgf / cm ² }
Wetted parts material	S	[Diaphragm] JIS SUS316L [Others] JIS SUS316L
	H	Hastelloy C-276 Hastelloy C-276
	T	Tantalum Tantalum *1
	U	Titanium Titanium
Process flange rating	J1	JIS 10K
	J2	JIS 20K
	J4	JIS 40K
	A1	ANSI class 150
	A2	ANSI class 300
	A4	ANSI class 600
	P1	JPI class 150
	P2	JPI class 300
	P4	JPI class 600
	D2	DIN PN10/16
	D4	DIN PN25/40
	D5	DIN PN64
Process flange size / material	D	3-inch (80 mm) / JIS S25C
	E	3-inch (80 mm) / JIS SUS304
	F	3-inch (80 mm) / JIS SUS316
	A	2-inch (50 mm) / JIS S25C
	B	2-inch (50 mm) / JIS SUS304
C	2-inch (50 mm) / JIS SUS316	
Cover flange bolts material	A	JIS SCM435
	B	JIS SUS630
Fill fluid	-A	For general use (silicone oil) [Process temp.] -10 to 250°C [Ambient temp.] -10 to 60°C
	-B	For general use (silicone oil) -30 to 180°C -15 to 60°C
	-C	For high temperature use (silicone oil) 10 to 300°C 10 to 60°C
	-D	For oil-prohibited use (fluorinated oil) -20 to 120°C -10 to 60°C
	-E	For low temperature use (ethylene glycol) -50 to 100°C -40 to 60°C
—	A	Always A
Capillary length (m)	<input type="checkbox"/> <input type="checkbox"/>	Specify capillary length from 1 to 10 m in <input type="checkbox"/> <input type="checkbox"/> . (Example for 2 m: 02)
Installation	-9	Horizontal impulse piping type, left side high pressure
Electrical connection	0	G1/2 female, one electrical connection
	2	1/2 NPT female, two electrical connections without blind plug
	3	PG 13.5 female, two electrical connections without blind plug
	4	M20 female, two electrical connections without blind plug
	5	G1/2 female, two electrical connections and a blind plug
	7	1/2 NPT female, two electrical connections and a blind plug
	8	PG 13.5 female, two electrical connections and a blind plug
	9	M20 female, two electrical connections and a blind plug
Integral indicator	A	G1/2 female, two electrical connections and a SUS316 blind plug
	C	1/2 NPT female, two electrical connections and a SUS316 blind plug
	D	M20 female, two electrical connections and a SUS316 blind plug
	D	Digital indicator
Mounting bracket	E	Digital indicator with the range setting switch
	N	(None)
	A ...	JIS SECC 2-inch pipe mounting (flat type)
Optional codes	B ...	JIS SUS304 2-inch pipe mounting (flat type)
	J ...	JIS SUS316 2-inch pipe mounting (flat type)
	N ...	(None)
Optional codes	/ <input type="checkbox"/>	Optional specification

Example: EJA118W-DMSA1A-AA02-92NA/

*1: In case of wetted parts material code T (Tantalum), maximum process temperature limits is 200°C.

● Model EJA118N

Model	Suffix Codes	Description
EJA118N	Diaphragm sealed differential pressure transmitter (Extended diaphragm type)
Output Signal	-D	4 to 20 mA DC with digital communication (BRAIN protocol)
	-E	4 to 20 mA DC with digital communication (HART protocol, see IM 01C22T01-01E)
	-F	Digital communication (FOUNDATION Fieldbus protocol, see IM 01C22T02-01E)
	-G	Digital communication (PROFIBUS PA protocol, see IM 01C22T03-00E)
Measurement span (capsule)	M	2.5 to 100 kPa {250 to 10000 mmH ₂ O}
	H	25 to 500 kPa {0.25 to 5 kgf / cm ² }
Wetted parts material	S	[Diaphragm] [Pipe] [Others] JIS SUS316L JIS SUS316 JIS SUS316
Process flange rating	J1	JIS 10K
	J2	JIS 20K
	A1	ANSI class 150
	A2	ANSI class 300
	P1	JPI class 150
	P2	JPI class 300
	D2	DIN PN10/16
D4	DIN PN25/40	
Diaphragm extension length (X ₂)	2	X ₂ = 50 mm
	4	X ₂ = 100 mm
	6	X ₂ = 150 mm
Process flange size / material	G	4-inch (100 mm) / JIS S25C
	H	4-inch (100 mm) / JIS SUS304
	J	4-inch (100 mm) / JIS SUS316
	D	3-inch (80 mm) / JIS S25C
	E	3-inch (80 mm) / JIS SUS304
	F	3-inch (80 mm) / JIS SUS316
Cover flange bolts material	A	JIS SCM435
	B	JIS SUS630
Fill fluid	-A	For general use (silicone oil) [Process temp.] [Ambient temp.] -10 to 250°C -10 to 60°C
	-B	For general use (silicone oil) -30 to 180°C -15 to 60°C
	-C	For high temperature use (silicone oil) 10 to 300°C 10 to 60°C
	-D	For oil-prohibited use (fluorinated oil) -20 to 120°C -10 to 60°C
	-E	For low temperature use (ethylene glycol) -50 to 100°C -40 to 60°C
	—	B
Capillary length (m)	□□	Specify capillary length from 1 to 10 m in □□. (Example for 2 m: 02)
Installation	-9	Horizontal impulse piping type, left side high pressure
Electrical connection	0	G1/2 female, one electrical connection
	2	1/2 NPT female, two electrical connections without blind plug
	3	PG 13.5 female, two electrical connections without blind plug
	4	M20 female, two electrical connections without blind plug
	5	G1/2 female, two electrical connections and a blind plug
	7	1/2 NPT female, two electrical connections and a blind plug
	8	PG 13.5 female, two electrical connections and a blind plug
	9	M20 female, two electrical connections and a blind plug
	A	G1/2 female, two electrical connections and a SUS316 blind plug
	C	1/2 NPT female, two electrical connections and a SUS316 blind plug
D	M20 female, two electrical connections and a SUS316 blind plug	
Integral indicator	D	Digital indicator
	E	Digital indicator with the range setting switch
	N	(None)
Mounting bracket	A	JIS SECC 2-inch pipe mounting (flat type)
	B	JIS SUS304 2-inch pipe mounting (flat type)
	J	JIS SUS316 2-inch pipe mounting (flat type)
	N	(None)
Optional codes	/ □	Optional specification

Example: EJA118N-DMSA12GA-AB02-92NA/□

● Model EJA118Y

Model	Suffix Codes	Description
EJA118Y	Diaphragm sealed differential pressure transmitter (Combination of extended diaphragm and flush diaphragm type)
Output Signal	-D -E -F -G	4 to 20 mA DC with digital communication (BRAIN protocol) 4 to 20 mA DC with digital communication (HART protocol, see IM 01C22T01-01E) Digital communication (FOUNDATION Fieldbus protocol, see IM 01C22T02-01E) Digital communication (PROFIBUS PA protocol, see IM 01C22T03-00E)
Measurement span (capsule)	M H	2.5 to 100 kPa {250 to 10000 mmH ₂ O} 25 to 500 kPa {0.25 to 5 kgf / cm ² }
High pressure side wetted (extended diaphragm type) parts material *1	S.....	[Diaphragm] [Pipe] [Others] JIS SUS316L JIS SUS316 JIS SUS316
Process flange rating	J1 J2 A1 A2 P1 P2 D2 D4	JIS 10K JIS 20K ANSI class 150 ANSI class 300 JPI class 150 JPI class 300 DIN PN10/16 DIN PN25/40
Diaphragm extension length (X ₂)	2 4 6	X ₂ = 50 mm X ₂ = 100 mm X ₂ = 150 mm
Process flange size / material	P Q R	High pressure side 4-inch (100 mm) / JIS S25C Low pressure side 3-inch (80 mm) / JIS S25C High pressure side 4-inch (100 mm) / JIS SUS304 Low pressure side 3-inch (80 mm) / JIS SUS304 High pressure side 4-inch (100 mm) / JIS SUS316 Low pressure side 3-inch (80 mm) / JIS SUS316
Cover flange bolts material	A B	JIS SCM435 JIS SUS630
Fill fluid	-A -B -C -D -E	[Process temp.] [Ambient temp.] For general use (silicone oil) -10 to 250°C -10 to 60°C For general use (silicone oil) -30 to 180°C -15 to 60°C For high temperature use (silicone oil) 10 to 300°C 10 to 60°C For oil-prohibited use (fluorinated oil) -20 to 120°C -10 to 60°C For low temperature use (ethylene glycol) -50 to 100°C -40 to 60°C
—	C.....	Always C
Capillary length (m)	□□.....	Specify capillary length from 1 to 10 m in □□. (Example for 2 m: 02)
Installation	-9	Horizontal impulse piping type, left side high pressure
Electrical connection	0 2 3 4 5 7 8 9 A C D	G1/2 female, one electrical connection 1/2 NPT female, two electrical connections without blind plug PG 13.5 female, two electrical connections without blind plug M20 female, two electrical connections without blind plug G1/2 female, two electrical connections and a blind plug 1/2 NPT female, two electrical connections and a blind plug PG 13.5 female, two electrical connections and a blind plug M20 female, two electrical connections and a blind plug G1/2 female, two electrical connections and a SUS316 blind plug 1/2 NPT female, two electrical connections and a SUS316 blind plug M20 female, two electrical connections and a SUS316 blind plug
Integral indicator	D..... E..... N.....	Digital indicator Digital indicator with the range setting switch (None)
Mounting bracket	A... B... J... N...	JIS SECC 2-inch pipe mounting (flat type) JIS SUS304 2-inch pipe mounting (flat type) JIS SUS316 2-inch pipe mounting (flat type) (None)
Optional codes	/ □	Optional specification

Example: EJA118Y-DMSA12PA-AC02-92NA/□

*1: Low pressure side (Flush diaphragm) wetted parts material: Diaphragm and others; SUS316L.

9.3 Optional Specifications

For FOUNDATION Fieldbus explosion protected type, see IM 01C22T02-01E.

For PROFIBUS PA explosion protected type, see IM 01C22T03-00E.

Item	Description	Code
Factory Mutual (FM)	FM Explosionproof Approval *1 Explosionproof for Class I, Division 1, Groups B, C and D Dust-ignitionproof for Class II/III, Division 1, Groups E, F and G Hazardous (classified) locations, indoors and outdoors (NEMA 4X) Division 2, 'SEALS NOT REQUIRED', Temp. Class: T6 Amb. Temp.: -40 to 60°C (-40 to 140°F)	FF1
	FM Intrinsically safe Approval *1 Intrinsically Safe for Class I, Division 1, Groups A, B, C & D, Class II, Division 1, Groups E, F & G and Class III, Division 1 Hazardous Locations. Nonincendive for Class I, Division 2, Groups A, B, C & D, Class II, Division 2, Groups E, F & G, and Class III, Division 1 Hazardous Locations. Enclosure: "NEMA 4X", Temp. Class: T4, Amb. Temp.: -40 to 60°C (-40 to 140°F) Intrinsically Safe Apparatus Parameters [Groups A, B, C, D, E, F and G] Vmax=30 V, Imax=165 mA, Pmax=0.9 W, Ci=22.5 nF, Li=730 µH [Groups C, D, E, F and G] Vmax=30 V, Imax=225 mA, Pmax=0.9 W, Ci=22.5 nF, Li=730 µH	FS1
	Combined FF1 and FS1 *1	FU1
ATEX	ATEX Flameproof Approval *2 Certificate: KEMA 02ATEX2148 II 2G Exd IIC T4, T5, T6 Amb. Temp.: T5; -40 to 80°C (-40 to 176°F), T4 and T6; -40 to 75°C (-40 to 167°F) Max. process Temp.: T4; 120°C (248°F), T5; 100°C (212°F), T6; 85°C (185°F)	KF21
	ATEX Intrinsically safe Approval *2 Certificate: KEMA 02ATEX1030X II 1G EEx ia IIC T4, Amb. Temp.: -40 to 60°C (-40 to 140°F) Ui=30 V, Ii=165 mA, Pi=0.9 W, Ci=22.5 nF, Li=730 µH	KS2
Canadian Standards Association (CSA)	CSA Explosionproof Approval *1 Certificate: 1089598 Explosionproof for Class I, Division 1, Groups B, C and D Dustignitionproof for Class II/III, Division 1, Groups E, F and G Division2 'SEALS NOT REQUIRED', Temp. Class: T4, T5, T6 Encl Type 4x Max. Process Temp.: T4; 120°C (248°F), T5; 100°C (212°F), T6; 85°C (185°F) Amb. Temp.: -40 to 80°C (-40 to 176°F) Process Sealing Certification Dual Seal Certified by CSA to the requirement of ANSI/ISA 12.27.01 No additional sealing required. Primary seal failure annunciation : at the zero adjustment screw	CF1
	CSA Intrinsically safe Approval *1 Certificate: 1053843 Intrinsically Safe for Class I, Groups A, B, C and D Class II and III, Groups E, F and G Nonincendive for Class I, Division 2, Groups A, B, C and D Class II, Division 2, Groups F and G and Class III (not use Safety Barrier) Encl Type 4x, Temp. Class: T4, Amb. Temp.: -40 to 60°C (-40 to 140°F) Vmax=30 V, Imax=165 mA, Pmax=0.9 W, Ci=22.5 nF, Li=730 µH Process Sealing Certification Dual Seal Certified by CSA to the requirement of ANSI/ISA 12.27.01 No additional sealing required. Primary seal failure annunciation : at the zero adjustment screw	CS1
	Combined CF1 and CS1 *1	CU1

Item	Description	Code
IECEX Scheme	IECEx Intrinsically safe, type n and Flameproof Approval *3 Intrinsically safe and type n Certificate: IECEx KEM 06.0007X Ex ia IIC T4, Ex nL IIC T4 Enclosure: IP67 Amb. Temp.: -40 to 60°C (-40 to 140°F), Max. Process Temp.: 120°C (248°F) Electrical Parameters: [Ex ia] Ui=30 V, li=165 mA, Pi=0.9 W, Ci=22.5 nF, Li=730 µH [Ex nL] Ui=30 V, Ci=22.5 nF, Li=730 µH Flameproof Certificate: IECEx KEM 06.0005 Ex d IIC T6...T4 Enclosure: IP67 Max.Process Temp.: T4;120°C (248°F), T5;100°C (212°F), T6; 85°C (185°F) Amb.Temp.: -40 to 75°C (-40 to 167°F) for T4, -40 to 80°C (-40 to 176°F) for T5, -40 to 75°C (-40 to 167°F) for T6	SU2
TIIS certification	TIIS Flameproof Approval, Ex do IIC T4X Certificate: C15296 (Without integral indicator) C15297 (With integral indicator) Amb. Temp.: -20 to 60°C, Process Temp.: -20 to 120°C	JF3
	TIIS Intrinsically safe Approval, Ex ia IIC T4 Certificate: C14632 Amb. Temp.: -20 to 60°C, Process Temp.: -20 to 120°C	JS3
Attached flameproof packing adapter	Electrical connection: G1/2 female	1 pc.
	Applicable cable: O. D. 8 to 12 mm	2 pcs.

- *1: Applicable for Electrical connection code 2 and 7 (1/2 NPT female).
- *2: Applicable for Electrical connection code 2, 4, 7 and 9 (1/2 NPT and M20 female).
- *3: Applicable for Electrical connection code 2, 4 and 7 (1/2 NPT and M20 female).

Item		Description	Code	
Painting	Color change	Amplifier cover only	P□	
		Amplifier cover and terminal cover, Munsell 7.5 R4/14	PR	
	Coating change	Epoxy resin-baked coating	X1	
316 SST exterior parts		Exterior parts on the amplifier housing (name plates, tag plates, zero-adjustment screw, stopper screw) will become 316 or 316L SST.	HC	
Fluoro-rubber O-ring		All O-rings of amplifier housing. Lower limit of ambient temperature : -15°C (5°F)	HE	
Lightning protector		Transmitter power supply voltg: 10.5 to 32 V DC (9 to 32 V DC for FOUNDATION Fieldbus and PROFIBUS PA communication type.) Allowable current: Max. 6000 A (1×40 μs), Repeating 1000 A (1×40 μs) 100 times	A	
Oil-prohibited use		Degrease cleansing treatment	K1	
Oil-prohibited use with dehydrating treatment		Degrease cleansing and dehydrating treatment	K5	
Calibration units	P calibration (psi unit)		(See Table for Span and Range Limits.) D1	
	bar calibration (bar unit)			D3
	M calibration (kgf/cm ² unit)			D4
Sealing treatment to JIS SUS630 nuts		Sealant (liquid silicone rubber) is coated on surfaces of SUS630 nuts used for cover flange mounting.	Y	
No serration		No serration work on the flange gasket surface (for ANSI flange only)	Q	
Teflon film		With FEP film and fluorinated oil Working range: 20 to 150°C, 0 to 2 MPa {0 to 20 kgf/cm ² } (Not usable under vacuum)	T	
Operating temperature correction		Adjusting range: 80°C to maximum process temperature according to the specified fill fluid code	R	
Capillary without PVC sheaths		When ambient temperature exceeds 100°C, or use of PVC is prohibited	V	
Fast response *2		Update time: 0.125 sec or less, see GS for response time	F1	
Failure alarm down-scale *1		Output status at CPU failure and hardware error is -5%, 3.2 mA or less.	C1	
NAMUR NE43 compliant *1	Output signal limits: 3.8 mA to 20.5 mA	Failure alarm down-scale: output status at CPU failure and hardware error is -5%, 3.2 mA or less.	C2	
		Failure alarm up-scale: output status at CPU failure and hardware error is 110%, 21.6 mA or more.	C3	
Data configuration at factory		Description into "Descriptor" parameter of HART protocol	CA	
Stainless steel amplifier housing		Amplifier housing material: JIS SCS14A stainless steel (equivalent to SUS316 cast stainless steel or ASTM CF-8M)	E1	
Gold-plate		Gold-plated diaphragm	A1	
Stainless steel tag plate		SUS304 tag plate wired onto transmitter	N4	
Mill Certificate	Process flange, Block (For model EJA118W)		M05	
	Process flange, Block, Pipe, Base (For model EJA118N)		M06	
	High pressure side: Process flange, Block, Pipe, Base (For model EJA118Y) Low pressure side: Process flange, Block		M07	
Pressure test/Leak test Certificate	(Flange rating)	(Test pressure)	Nitrogen(N ₂) Gas Retention time: 10 minutes	
	JIS 10K	2 MPa {20 kgf/cm ² }		T31
	JIS 20K	5 MPa {50 kgf/cm ² }		T32
	JIS 40K	10 MPa {100 kgf/cm ² }		T33
	ANSI/JPI Class 150	3 MPa {29.8 kgf/cm ² }		T36
	ANSI/JPI Class 300	7.7 MPa {77 kgf/cm ² }		T37
	ANSI/JPI Class 300	7 MPa {70 kgf/cm ² }		T38
ANSI/JPI Class 600	14 MPa {140 kgf/cm ² }	T39		

*1: Applicable for Output signal code D and E. The hardware error indicates faulty amplifier or capsule. When combining with Optional code F1, output status for down-scale is -2.5%, 3.6 mA DC or less.

*2: Applicable for Output signal code D and E. Write protection switch is attached for Output code E.

9.4 Dimensions

● Model EJA118W [Style: S2]

Unit: mm (approx.inch)

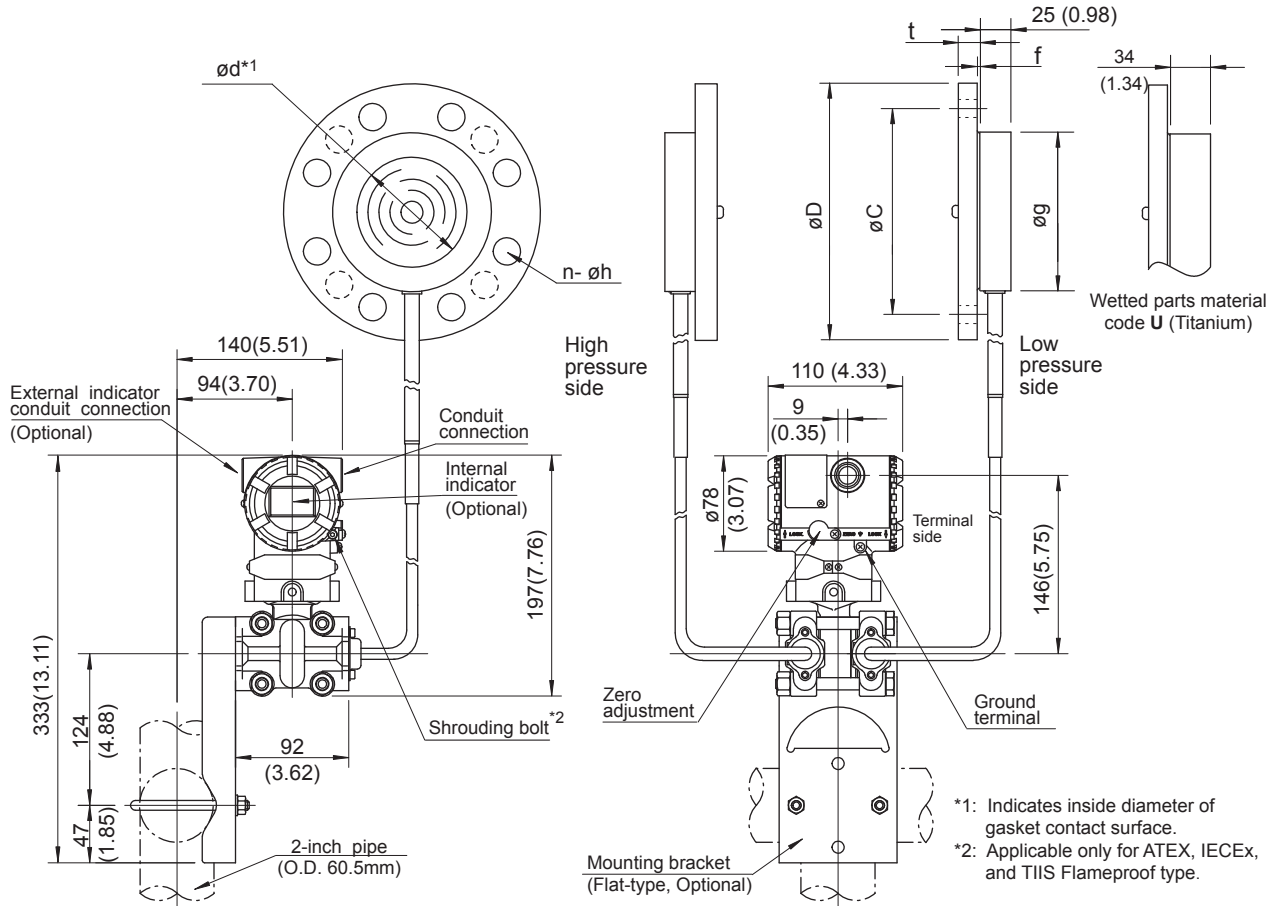

F0902.ai

Process flange size: 3-inch (80 mm)

Flange Rating	ϕD	ϕC	ϕg	ϕd	t	f^*	n	ϕh
JIS 10K	185(7.28)	150(5.91)	130(5.12)	90(3.54)	18(0.71)	0	8	19(0.75)
JIS 20K	200(7.87)	160(6.30)	130(5.12)	90(3.54)	22(0.87)	0	8	23(0.91)
JIS 40K	210(8.27)	170(6.69)	130(5.12)	90(3.54)	32(1.26)	0	8	23(0.91)
ANSI Class 150	190.5(7.50)	152.4(6)	130(5.12)	90(3.54)	23.9(0.94)	1.6(0.06)	4	19.1(0.75)
ANSI Class 300	209.6(8.25)	168.1(6.62)	130(5.12)	90(3.54)	28.5(1.12)	1.6(0.06)	8	22.4(0.88)
ANSI Class 600	209.6(8.25)	168.1(6.62)	130(5.12)	90(3.54)	38.2(1.50)	6.4(0.25)	8	22.4(0.88)
JPI Class 150	190(7.48)	152.4(6)	130(5.12)	90(3.54)	24(0.94)	1.6(0.06)	4	19(0.75)
JPI Class 300	210(8.27)	168.1(6.62)	130(5.12)	90(3.54)	28.5(1.12)	1.6(0.06)	8	22(0.87)
JPI Class 600	210(8.27)	168.1(6.62)	130(5.12)	90(3.54)	38.4(1.51)	6.4(0.25)	8	22(0.87)
DIN PN 10/16	200(7.78)	160(6.30)	130(5.12)	90(3.54)	20(0.79)	0	8	18(0.71)
DIN PN 25/40	200(7.78)	160(6.30)	130(5.12)	90(3.54)	24(0.94)	0	8	18(0.71)
DIN PN 64	215(8.46)	170(6.69)	130(5.12)	90(3.54)	28(1.10)	0	8	22(0.87)

Process flange size: 2-inch (50 mm)

Flange Rating	ϕD	ϕC	ϕg	ϕd	t	f^*	n	ϕh
JIS 10K	155(6.10)	120(4.72)	100(3.94)	61(2.40)	16(0.63)	0	4	19(0.75)
JIS 20K	155(6.10)	120(4.72)	100(3.94)	61(2.40)	18(0.71)	0	8	19(0.75)
JIS 40K	165(6.50)	130(5.12)	100(3.94)	61(2.40)	26(1.02)	0	8	19(0.75)
ANSI Class 150	152.4(6.00)	120.7(4.75)	100(3.94)	61(2.40)	19.1(0.75)	1.6(0.06)	4	19.1(0.75)
ANSI Class 300	165.1(6.50)	127.0(5.00)	100(3.94)	61(2.40)	22.4(0.88)	1.6(0.06)	8	19.1(0.75)
ANSI Class 600	165.1(6.50)	127.0(5.00)	100(3.94)	61(2.40)	31.8(1.25)	6.4(0.25)	8	19.1(0.75)
JPI Class 150	152(6.10)	120.6(4.75)	100(3.94)	61(2.40)	19.5(0.77)	1.6(0.06)	4	19(0.75)
JPI Class 300	165(6.50)	127.0(5.00)	100(3.94)	61(2.40)	22.5(0.89)	1.6(0.06)	8	19(0.75)
JPI Class 600	165(6.50)	127.0(5.00)	100(3.94)	61(2.40)	31.9(1.26)	6.4(0.25)	8	19(0.75)
DIN PN 10/16	165(6.50)	125(4.92)	100(3.94)	61(2.40)	18(0.71)	0	4	18(0.71)
DIN PN 25/40	165(6.50)	125(4.92)	100(3.94)	61(2.40)	20(0.78)	0	4	18(0.71)
DIN PN 64	180(7.09)	135(5.31)	100(3.94)	61(2.40)	26(1.02)	0	4	22(0.87)

* In case where process flange material is JIS S25C, value of f is 0.

● Model EJA118N [Style: S2]

Unit: mm (approx.inch)

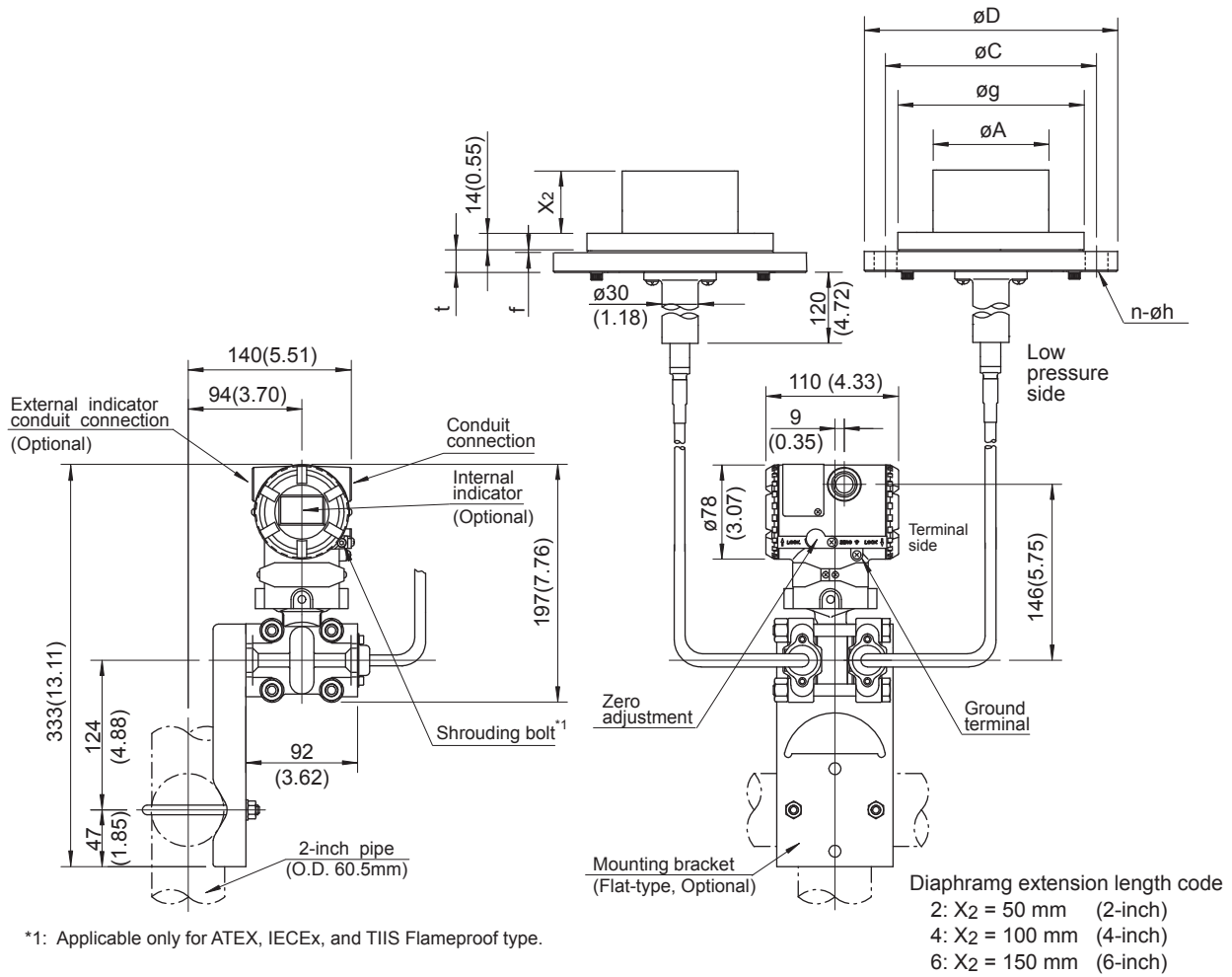

F0903.ai

Process flange size: 4-inch (100 mm)

Flange Rating	ØD	ØC	Øg	ØA	t	f*	n	Øh
JIS 10K	210(8.72)	175(6.89)	155(6.10)	96(3.78)	18(0.71)	0	8	19(0.75)
JIS 20K	225(8.86)	185(7.28)	155(6.10)	96(3.78)	24(0.94)	0	8	23(0.91)
ANSI Class 150	228.6(9.00)	190.5(7.50)	155(6.10)	96(3.78)	23.9(0.94)	1.6(0.06)	8	19.1(0.75)
ANSI Class 300	254(10.00)	200.2(7.88)	155(6.10)	96(3.78)	31.8(1.25)	1.6(0.06)	8	22.4(0.88)
JPI Class 150	229(9.02)	190.5(7.50)	155(6.10)	96(3.78)	24(0.94)	1.6(0.06)	8	19(0.75)
JPI Class 300	254(10.00)	200.2(7.88)	155(6.10)	96(3.78)	32(1.26)	1.6(0.06)	8	22(0.87)
DIN PN 10/16	220(8.66)	180(7.09)	155(6.10)	96(3.78)	20(0.79)	0	8	18(0.71)
DIN PN 25/40	235(9.25)	190(7.48)	155(6.10)	96(3.78)	24(0.94)	0	8	22(0.87)

Process flange size: 3-inch (80 mm)

Flange Rating	ØD	ØC	Øg	ØA	t	f*	n	Øh
JIS 10K	185(7.28)	150(5.91)	130(5.12)	71(2.80)	18(0.71)	0	8	19(0.75)
JIS 20K	200(7.87)	160(6.30)	130(5.12)	71(2.80)	22(0.87)	0	8	23(0.91)
ANSI Class 150	190.5(7.50)	152.4(6)	130(5.12)	71(2.80)	23.9(0.94)	1.6(0.06)	4	19.1(0.75)
ANSI Class 300	209.6(8.25)	168.1(6.62)	130(5.12)	71(2.80)	28.5(1.12)	1.6(0.06)	8	22.4(0.88)
JPI Class 150	190(7.48)	152.4(6)	130(5.12)	71(2.80)	24(0.94)	1.6(0.06)	4	19(0.75)
JPI Class 300	210(8.27)	168.1(6.62)	130(5.12)	71(2.80)	28.5(1.12)	1.6(0.06)	8	22(0.87)
DIN PN 10/16	200(7.78)	160(6.30)	130(5.12)	71(2.80)	20(0.79)	0	8	18(0.71)
DIN PN 25/40	200(7.78)	160(6.30)	130(5.12)	71(2.80)	24(0.94)	0	8	18(0.71)

* In case where process flange material is JIS S25C, value of f is 0.

● Model EJA118Y [Style: S2]

Unit: mm (approx.inch)

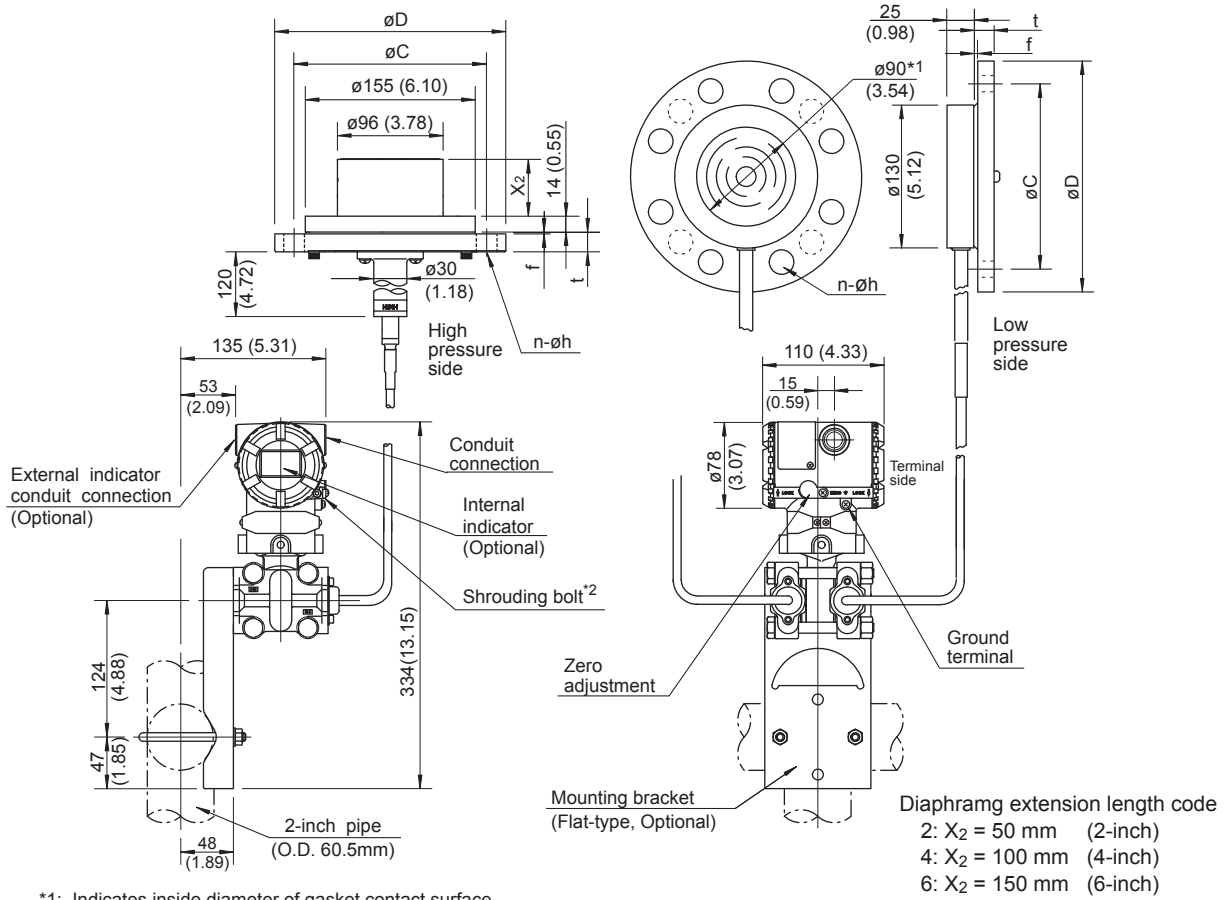

*1: Indicates inside diameter of gasket contact surface.
 *2: Applicable only for ATEX, IECEx, and TIIS Flameproof type.

F0904.ai

High pressure side Process flange size: 4-inch (100 mm)

Flange Rating	ØD	ØC	t	f*	n	Øh
JIS 10K	210(8.72)	175(6.89)	18(0.71)	0	8	19(0.75)
JIS 20K	225(8.86)	185(7.28)	24(0.94)	0	8	23(0.91)
ANSI Class 150	228.6(9.00)	190.5(7.50)	23.9(0.94)	1.6(0.06)	8	19.1(0.75)
ANSI Class 300	254(10.00)	200.2(7.88)	31.8(1.25)	1.6(0.06)	8	22.4(0.88)
JPI Class 150	229(9.02)	190.5(7.50)	24(0.94)	1.6(0.06)	8	19(0.75)
JPI Class 300	254(10.00)	200.2(7.88)	32(1.26)	1.6(0.06)	8	22(0.87)
DIN PN 10/16	220(8.66)	180(7.09)	20(0.79)	0	8	18(0.71)
DIN PN 25/40	235(9.25)	190(7.48)	24(0.94)	0	8	22(0.87)

Low pressure side Process flange size: 3-inch (80 mm)

Flange Rating	ØD	ØC	t	f*	n	Øh
JIS 10K	185(7.28)	150(5.91)	18(0.71)	0	8	19(0.75)
JIS 20K	200(7.87)	160(6.30)	22(0.87)	0	8	23(0.91)
ANSI Class 150	190.5(7.50)	152.4(6)	23.9(0.94)	1.6(0.06)	4	19.1(0.75)
ANSI Class 300	209.6(8.25)	168.1(6.62)	28.5(1.12)	1.6(0.06)	8	22.4(0.88)
JPI Class 150	190(7.48)	152.4(6)	24(0.94)	1.6(0.06)	4	19(0.75)
JPI Class 300	210(8.27)	168.1(6.62)	28.5(1.12)	1.6(0.06)	8	22(0.87)
DIN PN 10/16	200(7.78)	160(6.30)	20(0.79)	0	8	18(0.71)
DIN PN 25/40	200(7.78)	160(6.30)	24(0.94)	0	8	18(0.71)

* In case where process flange material is JIS S25C, value of f is 0.

Installation and Operating Precautions for TIIS Intrinsically Safe Equipment

Apparatus Certified Under Technical Criteria (IEC-compatible Standards) and from “RECOMMENDED PRACTICES for Explosion-Protected Electrical Installations in General Industries,” published in 1979

1. General

The following describes precautions on electrical apparatus of intrinsically safe construction (hereinafter referred to as intrinsically safe apparatus).

Following the Labor Safety and Health Laws of Japan, an intrinsically safe apparatus must undergo type tests in order to be certified by the Technical Institute of Industrial Safety, Inc. These tests are required to satisfy either the technical criteria for electrical machinery and equipment in compliance with explosionproof standards involving inflammable gases or vapors and for machinery and equipment having explosionproof performance (standards notification no. 556 from the Japanese Ministry of Labor) (hereinafter referred to as technical criteria), in conformity with IEC Standards, or the “Recommended Practice for Explosion-Protected Electrical Installations in General Industries,” published in 1979. Such a certified apparatus can be used in hazardous locations where inflammable gases or vapors may be present.

Certified apparatus includes a certification label and an equipment nameplate with the specifications necessary for explosion requirements as well as precautions on explosion protection. Please confirm these precautionary items and use them to meet specification requirements.

For electrical wiring and maintenance servicing, please refer to “Internal Wiring Rules” in the Electrical Installation Technical Standards as well as “USER’S GUIDELINES for Electrical Installations for Explosive Gas Atmospheres in General Industry,” published in 1994.

To meet intrinsically safe requirements, equipment that can be termed an “intrinsically safe apparatus” must:

- (1) be certified by the Technical Institute of Industrial Safety, Inc. in accordance with the Labor Safety and Health Laws of Japan and have the appropriate mark of certification labeled on its case, and
- (2) be used in compliance with the specifications marked on its certification label, equipment nameplate and precautionary information furnished.

Note: Intrinsically safe apparatus satisfy their performance under specific conditions. They are not always absolutely safe under every operational and environmental condition. In other words, they are not safe products involved with factors such as chemical reactions, geographical changes or the like other than affected by electric energy from the equipment itself.

2. Electrical Apparatus of Intrinsic Safety Type of Explosion-Protected Construction

The intrinsic safety type of explosion-protected construction is a method of protection applicable to a circuit or part of a circuit in which, under prescribed test conditions, no spark or thermal effect, whether produced normally or accidentally, is capable of causing a prescribed explosive gas to ignite. In other words, electrical apparatus of this construction is intended to suppress electrical energy thereby preventing ignition of a given explosive gas atmosphere even though spark or high thermal effect occurs in the electric circuitry.

Intrinsically safe electrical apparatus generally comprise intrinsically safe apparatus installed in a hazardous location and a safety barrier (associated apparatus), installed in a non-hazardous location, aimed at preventing electrical energy from flowing into the electric circuitry of intrinsically safe apparatus.

However, battery-operated, portable intrinsically safe apparatus or the like may be used alone.

3. Terminology

- (1) Intrinsically safe apparatus: Electrical apparatus in which all the circuits are intrinsically safe circuits.
- (2) Associated apparatus: Electrical apparatus in which there are both intrinsically safe circuits and non-intrinsically safe circuits that can affect the safety of intrinsically safe circuits.
- (3) Safety barrier: A specific type of associated apparatus, which consists mainly of safety barrier elements, and serves to limit the flow of excessive electrical energy, which is capable of causing ignition of a given explosive gas or vapour of a non-intrinsically safe circuit into concerned intrinsically safe circuits.
- (4) Apparatus of category “ia”: Intrinsically safe electrical apparatus and associated apparatus which are incapable of causing ignition of a given explosive gas or vapour with the appropriate safety factors such as:
 - when up to two countable faults are applied and, in addition,
 - when non-countable faults produce an onerous condition.
- (5) Apparatus of category “ib”: Intrinsically safe electrical apparatus and associated apparatus which are incapable of causing ignition of a given explosive gas or vapour, with the appropriate safety factors such as:
 - when up to one countable fault is applied and, in addition,
 - when non-countable faults produce an onerous condition.
- (6) Safety rating: A rating to be designated to intrinsically safe apparatus as well as associated apparatus and is the maximum rating allowable for maintaining intrinsic safety of concerned intrinsically safe circuits.

4. Caution on Combining Intrinsically Safe Apparatus and Safety Barriers

- (1) A combination of certified intrinsically safe apparatus and safety barriers needs to satisfy combination requirements. If intrinsically safe apparatus specify safety barriers for combination, safety barriers other than specified cannot be used (see Note 1 for more details).
- (2) Certified intrinsically safe systems specify specific safety barriers in combination with intrinsically safe apparatus. So safety barriers other than specified cannot be used (see Note 2 for more details).
- (3) Other than limitations of combining intrinsically safe apparatus and safety barriers as given in (1) and (2) above, two or more pieces of apparatus certified under different standards cannot be combined with each other (see Note 3 for more details). In addition, bear in mind that classifications of explosion protection such as “IIA,” “IIB” and “IIC” and category “ia” and “ib” limit a combination of intrinsically safe apparatus and safety barriers.

For more details, see the “Type Certificate Guide for Explosion-Protected Construction for Electrical Machinery and Equipment,” issued by the Japanese Ministry of Labour, the Research Institute of Industrial Safety.

Note 1: Testing Apparatus

Intrinsically safe apparatus and safety barriers are assessed individually to ensure that their safety requirements are satisfied. Tested and certified intrinsically safe apparatus and safety barriers incorporate individual certification numbers.

A combination of intrinsically safe apparatus and safety barriers involves the following two limitations:

- (1) A safety barrier which meets the combination requirements by referring to its safety rating and combination parameters shall be selected.
- (2) For pressure transmitters, pH transmitters, temperature detectors and the like, safety barriers that can be combined are already specified. Other safety barriers cannot be used.

Note 2: Testing Intrinsically Safe System

An assembly (as a system) in which intrinsically safe apparatus and safety barriers are combined is assessed to ensure that its safety requirements are satisfied. A tested and certified system incorporates a certification number (intrinsically safe apparatus and safety barriers have the same certification number).

Note 3: Impossible Combinations of Apparatus Certified Under Different Standards

Intrinsically safe apparatus certified under technical criteria and safety barriers certified under the "Recommended Practice for Explosion-Protected Electrical Installations in General Industries" (1979) and vice versa cannot be combined even if their combination requirements are satisfied.

5. Installation of Intrinsically Safe Apparatus and Safety Barriers

(1) Classification of installation location

Intrinsically safe apparatus may be installed, depending upon applicable gases, in a hazardous area in Zone 0, 1 or 2 (Note 4 below), where the specified gases are present. However, note that apparatus certified under Technical Criteria, in category "ib" shall be installed only in Zone 1 or 2. Safety barriers (associated apparatus) that are combined with these intrinsically safe apparatus shall be installed only in a non-hazardous area. In cases where safety barriers are installed in a hazardous area, they shall be enclosed, for example, in a flameproof enclosure.

Note 4: Hazardous areas are classified in zones based upon the frequency of the appearance and the duration of an explosive gas atmosphere as follows:

- Zone 0: An area in which an explosive gas atmosphere is present continuously or is present for long periods.
- Zone 1: An area in which an explosive gas atmosphere is likely to occur in normal operation.
- Zone 2: An area in which an explosive gas atmosphere is not likely to occur in normal operation and if it does occur it will exist for a short period only.

(2) Ambient temperature limits for intrinsically safe apparatus

Intrinsically safe apparatus shall be installed in a location where the ambient temperature ranges from -20°C to $+40^{\circ}\text{C}$ (for those certified under Technical Criteria) or -10°C to $+40^{\circ}\text{C}$ (for those certified under the "Recommended Practice for Explosion-Protected Electrical Installations in General Industries" (1979)). However, some field-mounted intrinsically safe apparatus may be used at an ambient temperature up to 60°C . So, specifications should be checked before installing intrinsically safe apparatus.

If the intrinsically safe apparatus are exposed to direct sunshine or radiant heat from plant facilities, appropriate thermal protection measures shall be taken.

6. Wiring for Intrinsically Safe Circuits

In intrinsically safe construction, safety shall be maintained as an intrinsically safe system involving intrinsically safe apparatus and safety barriers connected thereto, and electrical wiring (through intrinsically safe circuits) interconnected between them. In other words, even when safety requirements are maintained individually by intrinsically safe apparatus and safety barriers, they shall not be affected by electrical or magnetic energy caused by electrical wiring.

To make electrical wiring for intrinsically safe circuits, you must:

- (a) refer to the equipment configuration diagram and make electrical wiring properly;
- (b) prevent intrinsically safe wiring from being contacted with non-intrinsically safe wiring, and separate the intrinsically safe circuit from other electrical circuits;
- (c) prevent intrinsically safe wiring from being electrostatically and magnetically affected by non-intrinsically safe wiring;
- (d) reduce wiring inductance and capacitance produced between the intrinsically safe apparatus and safety barrier where possible, and use a shorter cable between the intrinsically safe apparatus and safety barrier than specified if the maximum permissible inductance of the cable is specified as operating conditions;
- (e) conform to conditions of installation such as wiring method, earthing or the like, if any; and
- (f) protect the outer sheath of cables from damage with appropriate measures.

7. Maintenance and Inspection of Intrinsically Safe Apparatus and Safety Barriers

Maintenance and inspection of intrinsically safe apparatus and safety barriers shall be limited to within the instructions described in applicable instruction manuals. If other than this is required, contact the manufacturers. For more information, refer to the "USER'S GUIDELINES for Electrical Installations for Explosive Gas Atmospheres in General Industry" issued in 1994 by the Japanese Ministry of Labour, the Research Institute of Industrial Safety.

(1) Requirements for maintenance personnel

Maintenance and inspection of intrinsically safe apparatus and safety barriers shall be conducted by maintenance personnel skilled in intrinsically safe construction and installation of electrical devices as well as capable of applying associated rules.

(2) Maintenance and Inspection

- (a) Visual inspection
Visually inspect the external connections of intrinsically safe apparatus and safety barriers, and cables for damage or corrosion as well as other mechanical and structural defects.
- (b) Adjustments
Zero, span and sensitivity adjustments shall be made with applicable adjusting potentiometers and mechanical adjustment screws.
These maintenance adjustments shall be made in a non-hazardous location.



CAUTION

If intrinsically safe apparatus and safety barriers require maintenance service and checking, a gas detector shall be used to ensure that there is no explosive gas in the location (maintenance servicing shall be conducted in a non-hazardous location).

(3) Repair

Intrinsically safe apparatus and safety barriers shall be repaired by manufacturers.

(4) Prohibition of modifications and specification changes

Do not attempt to make modifications or change specifications which may affect safety.

Installation and Operating Precautions for TIS Flameproof Equipment

Apparatus Certified Under Technical Criteria (IEC-compatible Standards)

1. General

The following describes precautions on electrical apparatus of flameproof construction (hereinafter referred to as flameproof apparatus) in explosion-protected apparatus.

Following the Labour Safety and Health Laws of Japan, flameproof apparatus is subjected to type tests to meet either the technical criteria for explosionproof electrical machinery and equipment (standards notification no. 556 from the Japanese Ministry of Labour) (hereinafter referred to as technical criteria), in conformity with the IEC Standards, or the "Recommended Practice for Explosion-Protected Electrical Installations in General Industries," published in 1979. These certified apparatus can be used in hazardous locations where explosive or inflammable gases or vapours may be present.

Certified apparatus includes a certification label and an equipment nameplate with the specifications necessary for explosion requirements as well as precautions on explosion protection. Please confirm these precautionary items and use them to meet specification requirements.

For electrical wiring and maintenance servicing, please refer to "Internal Wiring Rules" in the Electrical Installation Technical Standards as well as "USER'S GUIDELINES for Electrical Installations for Explosive Gas Atmospheres in General Industry," published in 1994.

To meet flameproof requirements, equipment that can be termed "flameproof" must:

- (1) Be certified by a Japanese public authority in accordance with the Labour Safety and Health Laws of Japan and have a certification label in an appropriate location on its case, and
- (2) Be used in compliance with the specifications marked on its certification label, equipment nameplate and precautionary information furnished.

2. Electrical Apparatus of Flameproof Type of Explosion-Protected Construction

Electrical apparatus which is of flameproof construction is subjected to a type test and certified by the Japanese Ministry of Labour aiming at preventing explosion caused by electrical apparatus in a factory or any location where inflammable gases or vapours may be present. The flameproof construction is of completely enclosed type and its enclosure shall endure explosive pressures in cases where explosive gases or vapours entering the enclosure cause explosion. In addition, the enclosure construction shall be such that flame caused by explosion does not ignite gases or vapours outside the enclosure.

In this manual, the word "flameproof" is applied to the flameproof equipment combined with the types of protection "e", "o", "i", and "d" as well as flameproof equipment.

3. Terminology

(1) Enclosure

An outer shell of an electrical apparatus, which encloses live parts and thus is needed to configure explosion-protected construction.

(2) Shroud

A component part which is so designed that the fastening of joint surfaces cannot be loosened unless a special tool is used.

(3) Enclosure internal volume

This is indicated by:— the total internal volume of the flameproof enclosure minus the volume of the internal components essential to equipment functions.

(4) Path length of joint surface

On a joint surface, the length of the shortest path through which flame flows from the inside to outside of the flameproof enclosure. This definition cannot be applied to threaded joints.

(5) Gaps between joint surfaces

The physical distance between two mating surfaces, or differences in diameters if the mating surfaces are cylindrical.

Note: The permissible sizes of gaps between joint surfaces, the path length of a joint surface and the number of joint threads are determined by such factors as the enclosure's internal volume, joint and mating surface construction, and the explosion classification of the specified gases and vapours.

4. Installation of Flameproof Apparatus

(1) Installation Area

Flameproof apparatus may be installed, in accordance with applicable gases, in a hazardous area in Zone 1 or 2, where the specified gases are present. Those apparatus shall not be installed in a hazardous area in Zone 0.

Note: Hazardous areas are classified in zones based upon the frequency of the appearance and the duration of an explosive gas atmosphere as follows:

- Zone 0: An area in which an explosive gas atmosphere is present continuously or is present for long periods.
- Zone 1: An area in which an explosive gas atmosphere is likely to occur in normal operation.
- Zone 2: An area in which an explosive gas atmosphere is not likely to occur in normal operation and if it does occur it will exist for a short period only.

(2) Environmental Conditions

The standard environmental condition for the installation of flameproof apparatus is limited to an ambient temperature range from -20°C to $+40^{\circ}\text{C}$ (for products certified under Technical Criteria). However, some field-mounted instruments may be certified at an ambient temperature up to $+60^{\circ}\text{C}$ as indicated on the instrument nameplates. If the flameproof apparatus are exposed to direct sunshine or radiant heat from plant facilities, appropriate thermal protection measures shall be taken.

5. External Wiring for Flameproof Apparatus

Flameproof apparatus require cable wiring or flameproof metal conduits for their electrical connections. For cable wiring, cable glands (cable entry devices for flameproof type) to wiring connections shall be attached. For metal conduits, attach sealing fittings as close to wiring connections as possible and completely seal the apparatus. All non-live metal parts such as the enclosure shall be securely grounded.

For details, see the "USER'S GUIDELINES for Electrical Installations for Explosive Gas Atmospheres in General Industry," published in 1994.

(1) Cable Wiring

- For cable wiring, cable glands (cable entry devices for flameproof type) specified or supplied with the apparatus shall be directly attached to the wiring connections to complete sealing of the apparatus.
- Screws that connect cable glands to the apparatus are those for G-type parallel pipe threads (JIS B 0202) with no sealing property. To protect the apparatus from corrosive gases or moisture, apply non-hardening sealant such as liquid gaskets to those threads for waterproofing.

- Specific cables shall be used as recommended by the "USER'S GUIDELINES for Electrical Installations for Explosive Gas Atmospheres in General Industry," published in 1994.
- In necessary, appropriate protective pipes (conduit or flexible pipes), ducts or trays shall be used for preventing the cable run (outside the cable glands) from damage.
- To prevent explosive atmosphere from being propagated from Zone 1 or 2 hazardous location to any different location or non-hazardous location through the protective pipe or duct, apply sealing of the protective pipes in the vicinity of individual boundaries, or fill the ducts with sand appropriately.
- When branch connections of cables, or cable connections with insulated cables inside the conduit pipes are made, a flameproof or increased-safety connection box shall be used. In this case, flameproof or increased-safety cable glands meeting the type of connection box must be used for cable connections to the box.

(2) Flameproof Metal Conduit Wiring

- For the flameproof metal conduit wiring or insulated wires shall be used as recommended by the USER'S GUIDELINES for Electrical Installations for Explosive Gas Atmospheres in General Industry, published in 1994.
- For conduit pipes, heavy-gauge steel conduits conforming to JIS C 8305 Standard shall be used.
- Flameproof sealing fittings shall be used in the vicinity of the wiring connections, and those fittings shall be filled with sealing compounds to complete sealing of the apparatus. In addition, to prevent explosive gases, moisture, or flame caused by explosion from being propagated through the conduit, always provide sealing fittings to complete sealing of the conduit in the following locations:
 - (a) In the boundaries between the hazardous and non-hazardous locations.
 - (b) In the boundaries where there is a different classification of hazardous location.
- For the connections of the apparatus with a conduit pipe or its associated accessories, G-type parallel pipe threads (JIS B 0202) shall be used to provide a minimum of five-thread engagement to complete tightness. In addition, since these parallel threads do not have sealing property, non-hardening sealant such as liquid gaskets shall thus be applied to those threads for ensuring waterproofness.
- If metal conduits need flexibility, use flameproof flexible fittings.

6. Maintenance of Flameproof Apparatus

To maintain the flameproof apparatus, do the following. (For details, see Chapter 10 "MAINTENANCE OF EXPLOSION-PROTECTED ELECTRICAL INSTALLATION" in the USER'S GUIDELINES for Electrical Installations for Explosive Gas Atmospheres in General Industry.)

(1) Maintenance servicing with the power on.

Flameproof apparatus shall not be maintenance-serviced with its power turned on. However, in cases where maintenance servicing is to be conducted with the power turned on, with the equipment cover removed, always use a gas detector to check that there is no explosive gas in that location. If it cannot be checked whether an explosive gas is present or not, maintenance servicing shall be limited to the following two items:

- (a) Visual inspection
Visually inspect the flameproof apparatus, metal conduits, and cables for damage or corrosion, and other mechanical and structural defects.
- (b) Zero and span adjustments
These adjustments should be made only to the extent that they can be conducted from the outside without opening the equipment cover. In doing this, great care must be taken not to cause mechanical sparks with tools.

(2) Repair

If the flameproof apparatus requires repair, turn off the power and transport it to a safety (non-hazardous) location. Observe the following points before attempting to repair the apparatus.

- (a) Make only such electrical and mechanical repairs as will restore the apparatus to its original condition. For the flameproof apparatus, the gaps and path lengths of joints and mating surfaces, and mechanical strength of enclosures are critical factors in explosion protection. Exercise great care not to damage the joints or shock the enclosure.
- (b) If any damage occurs in threads, joints or mating surfaces, inspection windows, connections between the transmitter and terminal box, shrouds or clamps, or external wiring connections which are essential in flameproofness, contact Yokogawa Electric Corporation.



CAUTION

Do not attempt to re-process threaded connections or refinish joints or mating surfaces.

- (c) Unless otherwise specified, the electrical circuitry and internal mechanisms may be repaired by component replacement, as this will not directly affect the requirements for flameproof apparatus (however, bear in mind that the apparatus must always be restored to its original condition). If you attempt to repair the flameproof apparatus, company-specified components shall be used.
- (d) Before starting to service the apparatus, be sure to check all parts necessary for retaining the requirements for flameproof apparatus. For this, check that all screws, bolts, nuts, and threaded connections have properly been tightened.

(3) Prohibition of specification changes and modifications

Do not attempt to change specifications or make modifications involving addition of or changes in external wiring connections.

7. Selection of Cable Entry Devices for Flameproof Type



IMPORTANT

The cable glands (cable entry devices for flameproof type) conforming to IEC Standards are certified in combination with the flameproof apparatus. So, Yokogawa-specified cable entry devices for flameproof type shall be used to meet this demand.

References:

- (1) Type Certificate Guide for Explosion-Protected Construction Electrical Machinery and Equipment (relating to Technical Standards Conforming to International Standards), issued by the Technical Institution of Industrial Safety, Japan
- (2) USER'S GUIDELINES for Electrical Installations for Explosive Gas Atmospheres in General Industry (1994), issued by the Japanese Ministry of Labour, the Research Institute of Industrial Safety.

Customer Maintenance Parts List

DPharp EJA Series Transmitter Section

DPharp

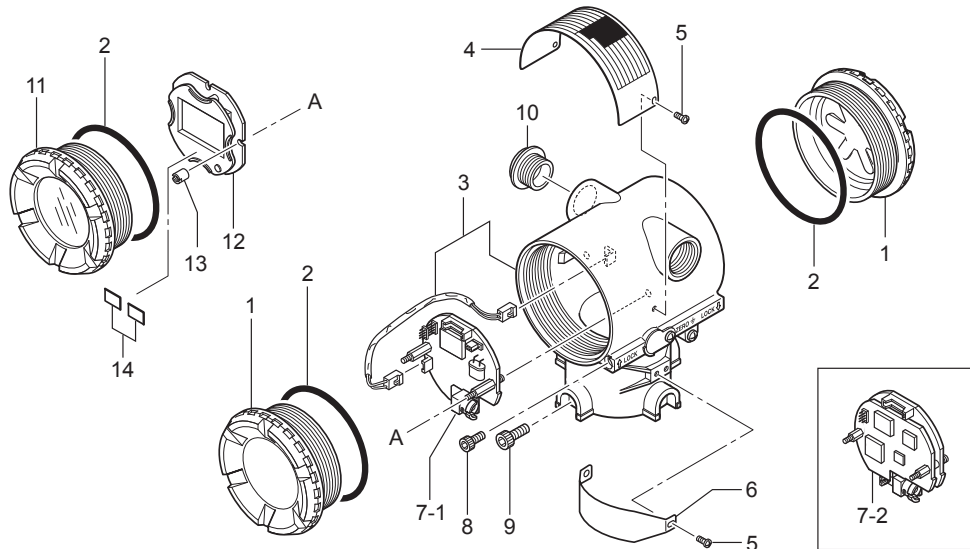

Item	Part No.	Qty	Description
1	Bellow F9341RA F9341RJ	2	Cover Cast-aluminum alloy SCS14A stainless steel
2	F9341JP	2	O-ring
3	Below	1	Case Assembly (Note 1)
	F9341AA F9341AC F9341AE F9341AH F9341AJ		Cast-aluminum alloy for G1/2 Cast-aluminum alloy for G1/2 (two electrical connections) Cast-aluminum alloy for 1/2 NPT (two electrical connections) Cast-aluminum alloy for M20 (two electrical connections) Cast-aluminum alloy for Pg13.5 (two electrical connections)
4	F9341AR	1	SCS14A stainless steel for 1/2 NPT (two electrical connections) Name Plate
5	Below F9900RG F9900RR	4	Screw For cast-aluminum alloy case assembly For SCS14A stainless steel case assembly
6	F9341KL	1	Tag Plate
7-1	Below F9342AB F9342AL F9342AJ	1	CPU Assembly For BRAIN protocol version (Except TIIS Intrinsically safe type) For HART protocol version (Except TIIS Intrinsically safe type) For BRAIN protocol version TIIS Intrinsically safe type (Optional code /JS3)
7-2	F9342AD F9342AF F9342AM F9342BF F9342BG	1	For BRAIN protocol version TIIS Intrinsically safe type with /F1(Optional code /JS3 and /F1) For BRAIN protocol version (Optional code /F1) For HART protocol version with write protection switch (Optional code /F1) For FOUNDATION Fieldbus protocol For FOUNDATION Fieldbus protocol with PID/LM function (Optional code /LC1)
8	F9900RP	2	Cap Screw
9	Y9612YU	2	Screw
10	Below F9340NV F9340NX	1	Plug For Pg13.5 For M20
11	G9330DP G9612EB Below F9341FM F9341FJ	1	For G1/2 For 1/2 NPT Cover Assembly Cast-aluminum alloy SCS14A stainless steel
12	Below F9342BL F9342BM	1	LCD Board Assembly Without range-setting switch With range-setting switch
13	F9342MK	2	Mounting Screw
14	F9300PB	2	Label

} For integral indicator

Note 1 : Applicable for BRAIN and HART Protocol version (Output signal code D and E).
For FOUNDATION Fieldbus protocol version (Output signal code F), contact Yokogawa local office.

Customer Maintenance Parts List

Models EJA118W, EJA118N and EJA118Y *DP^{harp}*
Diaphragm Sealed
Differential Pressure Transmitter
(Pressure-detector Section)

Model EJA118W

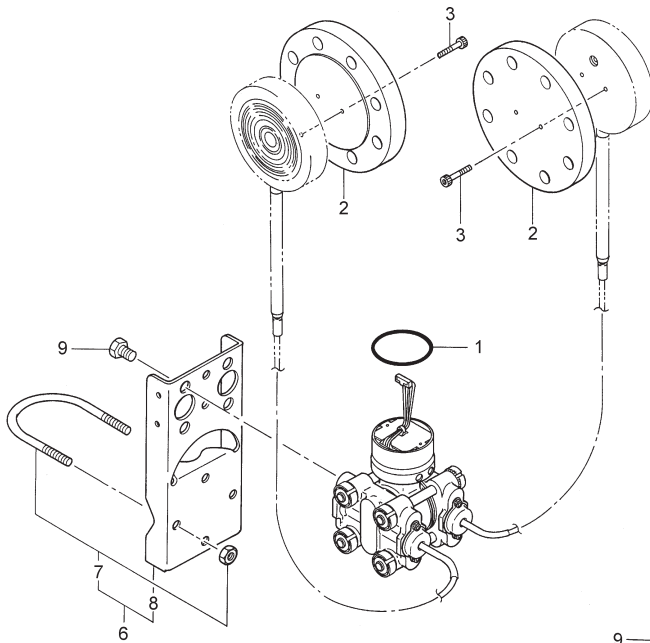

Model EJA118Y

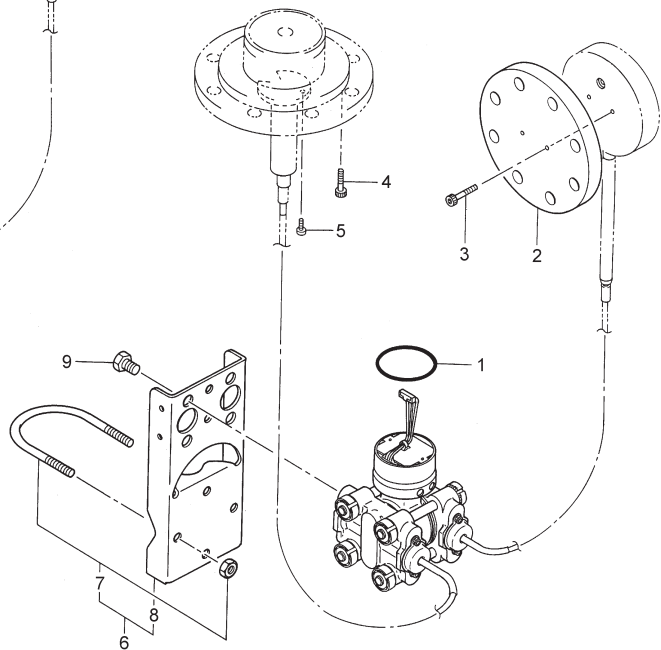

Model EJA118N

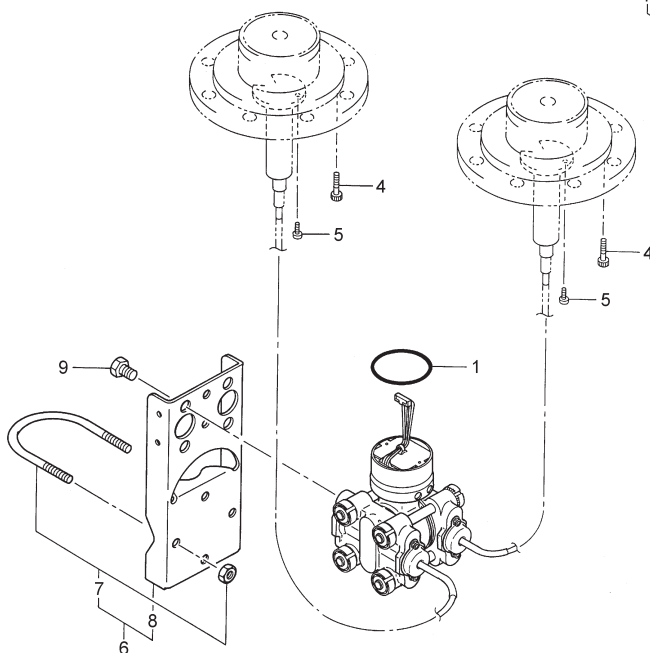

Item	Part No.	Model	Qty			Description
			EJA118W	EJA118N	EJA118Y	
1	F9300AJ	1	1	1	1	O-Ring
2	—	2	1	1	1	Flange
3	—	4	2	2	2	Bolt
4	Below Y9625YU	8	4	4	4	Bolt For JIS 10K
	Y9630YU					For JIS 20K, ANSI Class 150 and JPI Class 150
	Y9640YU					For ANSI Class 300 and JPI Class 300 (for Flange Size 100 mm, 4 inch)
	Y9635YU					For ANSI Class 300 and JPI Class 300 (for Flange Size 80 mm, 3 inch)
5	Y9612HU	8	4	4	4	Screw, M6 x 12
6	Below	1	1	1	1	Bracket Assembly
	F9270AW					SECC Carbon Steel
	F9300TA					SUS304 Stainless Steel
7	D0117XL-A	1	1	1	1	U-Bolt / Nut Assembly, SUS304 Stainless Steel
8	Below F9270AX	1	1	1	1	Bracket SECC Carbon Steel
	F9300TE					SUS304 Stainless Steel
9	Below F9270AY F9273CZ	4	4	4	4	Bolt S15C Carbon Steel SUS XM7 Stainless Steel

Table 1. Flange and Bolt Parts Number

Flange Rating	Flange Material (Item 2)			Bolt (Item 3)	Applicable Model
	S25C Carbon Steel	SUS304 Stainless Steel	SUS316 Stainless Steel		
80 mm JIS 10K	F9351KA	F9351GA	F9351WD	Y9525ZU	EJA118W and EJA118Y
80 mm JIS 20K	F9351KB	F9351GB	F9351WE	Y9530ZU	
80 mm JIS 40K	F9351KC	F9351GC	F9351WF	Y9540ZU	
3 inch ANSI Class 150	F9351KE	F9351GE	F9351WK	Y9530ZU	
3 inch ANSI Class 300	F9351KF	F9351GF	F9351WL	F9347VX	
3 inch ANSI Class 600	F9351KG	F9351GG	F9351WM	Y9540ZU	
3 inch JPI Class 150	F9351KH	F9351GH	F9351WR	Y9530ZU	
3 inch JPI Class 300	F9351KJ	F9351GJ	F9351WS	F9347VX	
3 inch JPI Class 600	F9351KK	F9351GK	F9351WT	Y9540ZU	
50 mm JIS 10K	F9351KP	F9351GP	F9351WA	Y9520ZU	
50 mm JIS 20K	F9351KQ	F9351GQ	F9351WB	Y9525ZU	
50 mm JIS 40K	F9351KR	F9351GR	F9351WC	Y9530ZU	
2 inch ANSI Class 150	F9351KT	F9351GT	F9351WG	Y9525ZU	
2 inch ANSI Class 300	F9351KU	F9351GU	F9351WH	Y9530ZU	
2 inch ANSI Class 600	F9351KV	F9351GV	F9351WJ	F9347VX	
2 inch JPI Class 150	F9351KW	F9351GW	F9351WN	Y9525ZU	
2 inch JPI Class 300	F9351KX	F9351GX	F9351WP	Y9530ZU	
2 inch JPI Class 600	F9351KY	F9351GY	F9351WQ	F9347VX	

Revision Information

- Title : Model EJA118W, EJA118N, and EJA118Y
Diaphragm Sealed Differential Pressure Transmitter
- Manual No. : IM 01C22H01-01E

Edition	Date	Page	Revised Item															
9th	Sep. 1998	2-14 2-15 7-20 10-3 10-4 10-5 CMPL	<p>2.10 Delete EMC Conformity Standards Tables and move the section to Page 2-14.</p> <p>2.10 Remove Page 2-15.</p> <p>7.3.2(11) Correction made in BURN OUT figure.</p> <p>10.1.2 Add Process flange size / material code F and C. Add Electrical connection code 7, 8, and 9.</p> <p>Add Process flange size / material code F and J. Add Electrical connection code 7, 8, and 9.</p> <p>Add Process flange size / material code R. Add Electrical connection code 7, 8, and 9.</p> <p>CMPL 1C22A1-02E 4th → 5th Page 2 Add Part No. to Item 3 (For PG13.5 and M20). Add Part No. to Item 10 (For 1/2NPT, PG13.5, and M20).</p> <p>CMPL 1C22H1-01E 1st → 2nd Page 4 Add SUS316 Stainless Steel Part No. to Flange material in Table1. Part No. correction made in Table1.</p> <table style="margin-left: 40px;"> <tr> <td>(Incorrect)</td> <td>→</td> <td>(Correct)</td> </tr> <tr> <td>F9315KA</td> <td>→</td> <td>F9351KA</td> </tr> <tr> <td>F9315KB</td> <td>→</td> <td>F9351KB</td> </tr> <tr> <td>F9315GA</td> <td>→</td> <td>F9351GA</td> </tr> <tr> <td>F9315GB</td> <td>→</td> <td>F9351GB</td> </tr> </table>	(Incorrect)	→	(Correct)	F9315KA	→	F9351KA	F9315KB	→	F9351KB	F9315GA	→	F9351GA	F9315GB	→	F9351GB
(Incorrect)	→	(Correct)																
F9315KA	→	F9351KA																
F9315KB	→	F9351KB																
F9315GA	→	F9351GA																
F9315GB	→	F9351GB																
10th	Feb. 2000	– 2-9 4-1 5-1 5-3 7-4 – 9-7 CMPL	<p>Changed to Electronic File Format. Revised a book in a new format. (The location of contents and the associated page numbers may not coincide with the one in old editions.)</p> <p>Major Revised Items:</p> <ol style="list-style-type: none"> 1. Explosion class and option code of JIS flameproof approval. Explosion class: Ex ds IIC T4(old) to Ex do IIC T4X(new). Option code: /JF1(old) to /JF3(new) 2. Option code for flameproof packing adapter for JIS flameproof approval. Option code: /G1 and /G2(old) to /G11 and /G12(new) 3. Add "Pa" and "hPa" as the unit for calibration range. 4. Part number change for CPU Board Assembly. <p>2.9 Add Figure 2.3 Example of using DCS.</p> <p>2.10 Add AS/NZS 2064 1/2 to EMI, EMC Conformity Standards.</p> <p>4.2 Correct the place of the high and low identification labels for remote diaphragm seals.</p> <p>5.2 Add selection in the case of JIS flameproof type.</p> <p>5.4.2 Change option code for flame packing adapter. Option code: G1 and G2 → G11 and G12 Change Applicable cable O.D. and Identifying mark. Part number: G9601AH → G9601AM Change the figure of flame proof packing adapter in Figure 5.4.2c.</p> <p>7.3.1 Add Pa and hPa to C20 and D31.</p> <p>– Installation and Operating Precautions for JIS Intrinsically Safe and Explosionproof Equipment: EX-A01E → EX-A03E, EX-B01E → EX-B03E</p> <p>9-3 Add Optional code F1.</p> <p>CMPL 1C22A1-02E 5th → 6th Change a format. Change and add Part No. of Item 7-1, CPU assembly: Change; F9342BC → F9342BB, F9342BK → F9342BJ Add; F9342AF, F9342AM Change Part No. of Item 10, Plug: G9330DK → G9330DP</p> <p>CMPL 1C22H1-01E 3rd Change a format</p>															

Edition	Date	Page	Revised Item
11th	Sep. 2000	2-8 2-9 3-1 7-4, 7-5 7-6 7-8 7-12 7-15 9-1 9-6 CMPL	2.9.4b Change ambient Temperature limit and add Caution for cable wiring. 2.9.5b Add Caution for /JS3 3 Add Note for /F1 7.3.1 Add parameter E10, E14 and E15. Add Note for /F1. 7.3.2 Add Ambient Temperature Zero Shift Compensation. 7.3.3(3) Add Note for /F1. 7.3.3(11)(12) Add Note for /F1. 7.3.3(16) Add Note for /F1. 7.3.3(17) Add (17) Ambient Temperature Zero Shift Compensation. 9.1 Change the capsule damping time constant. 9.3 Add /JS3 and delete /JS1. Change Amb.Temp. for /KF1 CMPL 1C22A1-02E 6th → 7th Add Parts No. to item 7-1 (For /JS3 and /F1) Add Parts No. to item 7-2 (For /LC1) CMPL 1C22A1-02E 7th → 8th Add Note for Case Assembly
12th	July 2001	2-10 7-4, 7-5 CMPL	2.10 Change EMC Conformity number. 7.3.1 Add footnote (*6) to B40, Maximum static pressure in Parameter Summary. CMPL 1C22A1-02E 8th → 9th (Manual Change) Change Part No. of CPU Assembly for BRAIN protocol. F9342BB → F9342AB CMPL 1C22A1-02E 9th → 10th (Manual Change) Change Part No. of CPU Assembly for HART protocol. F9342BH → F9342AL CMPL 1C22A1-02E 10th → CMPL 01C22A01-02E 11th Delete Part No. of Name Plate. Change Part No. of Screw. F9303JU → Y9303JU CMPL 1C22H1-01E 3rd → CMPL 01C22H01-01E 4th
13th	May 2002	1-2 2-7 9-6 9-7	1.1 Add "1.1 For Safety Using." 2.9.4 Add descriptions based on ATEX directive. 9.3 Add Optional code K□2. Add Optional code C2 and C3.
14th	Apr. 2003	2-8 2-11 9-6	2.9.4 Add Option code KU2. 2.11 Add PED (Pressure Equipment Directive). 9.3 Add Option code KU2.
15th	Apr. 2006	1-2 1-3 2-6 2-11 2-12 7-16 9-6, 9-7 9-7 9-8 CMPL	1.1 Add (e) Explosion Protected Type Instrument and (f) Modification 1.3 Add "1.3 ATEX Document" 2.9.3 Add "IECEX Certification" and delete "SAA Certification" 2.9.5 JIS Certification → TIIS Certification 2.12 Add Low Voltage Directive 7.3.3(17) Correct the definition of "h" 10.3 Add Certificate numbers and Applicable standards Add option code /SU2 and delete option code /SU1 Add option code /PR and /N4 CMPL 01C22A01-02E 11th → 12th JIS Intrinsically safe type → TIIS Intrinsically safe type
16th	Jan. 2008	1-1 1-4 2-3+ 2-12 4-4 7-15 8-4 9-1+ 9-6, -7 CMPL	Add direct current symbol. Add 11 European languages for ATEX documentation. 2.9.1 Add applicable standard and certificate number for approvals. 2.10 Add EMC caution note. 4.6 Add section of changing the direction of integral indicator. 7.3.3(15) Add figure for A40. 8.4.1 Add figure of integral indicator direction. 9.1, 9.2 Add PROFIBUS PA communication type. 9.3 Delete applicable standard from the table. CMPL 01C22A01-02E 12th → CMPL 01C22A01-02E 13th Delete logo from the tag plate.

Edition	Date	Page	Revised Item
17th	Oct. 2008	2-9 2-12 7-4, 7-5 7-6 7-9 and later 7-20 8-1 9-3, 9-4, 9-5 9-7, 9-8 CMPL	2.9.4 Change explosion protection marking for type n from EEx to Ex. 2.10 Update EMC conformity standards. 7.3.1 Add new parameters. 7.3.2 Add items in table 7.3.1. 7.3.3 Add (6) Change Output Limit and (17) Span Adjustment. Re-number the items. 7.5.2 Modify descriptions and notes for Er.01. 8.3 Add a note for calibration. 9.2 Add new suffix codes. 9.3 Add Sealing statement for CSA.standards. Add /HC. CMPL 01C22A01-02E 13th → 14th Change Part No. of items 5 and 8
18th	July 2015	2-5, 2-6 2-9 to 2-10 2-12 2-12 7-1 9-1 9-7 to 9-9	2.9.2 Add temperature limitation for /HE. 2.9.4 b Change /KF2 to /KF21 and modify descriptions. Delete c. Replace tag plate. 2.10 Add standards. 2.12 Add (3) and (4). 7.1.1 Add note. 7.1.2 Add descriptions. 9.1 Add information to "EMC Conformity Standards". 10.3 Delete codes KU2 and KF2. Add KF21. Add Codes HE and CA.