

# **TopWorx™ D-Series Valve Controllers**

## **Master Installation, Operation & Maintenance Manual**



**TOPWORX**

  
**EMERSON**  
Process Management

## Emerson Process Management

Emerson Process Management is a powerful, global, single source of process improvement technology and expertise. We help major companies in selected industries optimize their plants and processes to achieve higher quality, greater reliability and faster time to market, while steadily advancing productivity and profitability.

Emerson's technology know-how and application experience enable us to develop products and solutions that deliver the proven performance and reliability our customers expect when looking to build, connect, improve, and maintain their equipment and automation process.

# Reliable Solutions

## Table of Contents

ES-04529-1	Table of Contents
ES-04530-1	Installation on Actuator
ES-04531-1	GO™ Switch: Options L2/L4/Z2/Z4
ES-04532-1	Mechanical Switches: Options M2/M4/M6/K2/K4/K6/T2
ES-04533-1	Inductive Sensors: Options E2/E4/E6/ V2/V4
ES-04534-1	4-20mA Transmitter: Options LX/MX/KX/EX/TX/ZX/OX
ES-04535-1	D2-FF Discrete Valve Controller Description
ES-04536-1	AS-I Sensor Communication Module (SCM) : Option AS
ES-04537-1	Reed Switch Sensor Communication Module (SCM) Calibration
ES-04538-1	ESD Theory of Operation
ES-04539-1	DeviceNet Sensor Communication Module (SCM): Option DN
ES-04540-1	Pneumatic Hookup Procedures
ES-04541-1	Proof Testing for TopWorx™ D-Series
ES-04542-1	Dimensions and Materials: TopWorx™ DXP
ES-04543-1	Dimensions and Materials: TopWorx™ DXP - Flameproof Ex d IIC
ES-04544-1	Dimensions and Materials: TopWorx™ DXS
ES-04545-1	Dimensions and Materials: TopWorx™ DXR
ES-04546-1	Indicator Assembly
ES-04547-1	TopWorx™ Certifications
ES-04547-1	Safe Use
ES-04549-1	TopWorx™ D-Series Replacement Part Number List
ES-04550-1	Recommended Operating Temperatures
ES-04551-1	Warranty

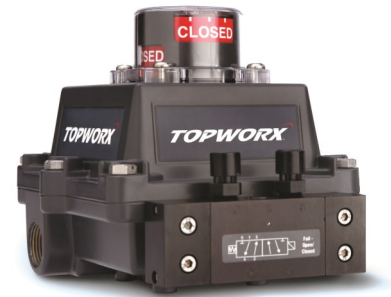

## Installation on Actuator Orientations, Normal and Reverse Acting

Normal acting is full clockwise when the process valve is closed and counterclockwise when the process valve is open. Reverse acting is full clockwise when the process valve is open and counterclockwise when the process valve is closed.

90° indicator dome assemblies are designed to accommodate any mounting arrangement and can be adjusted up to 9° off axis if needed. 45° indicator dome assemblies can only accommodate normal acting applications that are mounted parallel  $\pm 9^\circ$ . Consult your local distributor

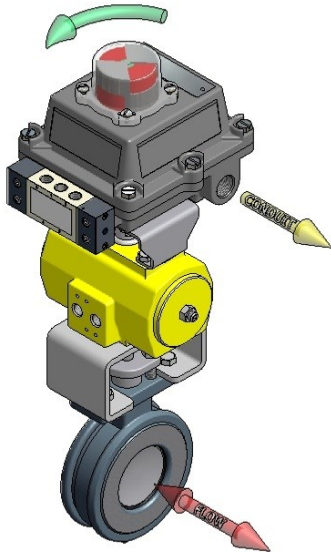

The image to the left shows a TopWorx™ unit mounted parallel to the process valve in the closed position. The green arrow at the top shows the “normal acting” direction of travel to open the valve. This is the standard orientation and unless otherwise specified, your unit will be factory set to operate in this fashion.

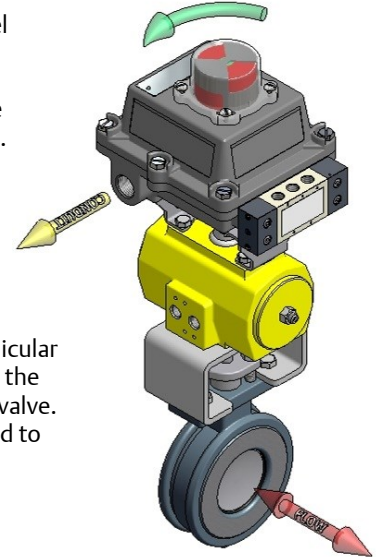

The image to the right shows a TopWorx™ mounted perpendicular to the process valve in the closed position. The green arrow at the top shows the “normal acting” direction of travel to open the valve. Notice that the indicator dome has been rotated 90° compared to the unit above.

## Mounting

TopWorx™ has numerous mounting bracket kits, both rotary and linear, available to meet your specific application. Consult your local distributor or factory representative for ordering information. The illustration below shows a direct NAMUR mount on a quarter turn valve. Refer to your mounting kit documentation for specific mounting instructions.



## Storage

Until conduit, conduit covers, and any applicable spool valve port connections are properly installed, the TopWorx™ unit will not support its IP/NEMA rating as the unit ships with temporary covers. Ensure that it is stored in a dry environment with a relative humidity range between 10%-95% and a temperature ranging from -40°F (-40°C) to 160°F (71°C). Once properly installed, the temperature range listed on the nameplate will supersede this storage temperature range.

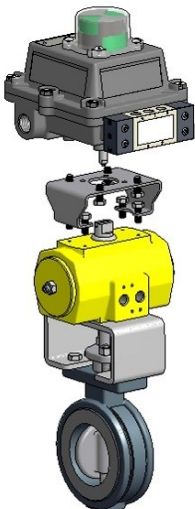
## Mounting Assembly



### Installation Notes

1. Use caution not to allow undue axial (thrust) load on the shaft.
2. Cycle the valve a couple of times prior to final tightening of the mounting kit hardware. This allows the shaft to self-center in the pinion slot, or coupler. Refer to the dimensions and materials section of this document for appropriate tightening torque. Please refer to the Proof Testing section for proper safety function set-up.
3. Always use sound mechanical practices when applying torque to any hardware or making pneumatic connections. Refer to the Integrated Pneumatic Control Valves section for detailed information.
4. This product comes shipped with conduit covers in an effort to protect the internal components from debris during shipment and handling. **It is the responsibility of the receiving and/or installing personnel to provide appropriate permanent sealing devices to prevent the intrusion of debris or moisture when stored or installed outdoors.** 
5. **It is the responsibility of the installer, or end user, to install this product in accordance with the National Electrical Code (NFPA 70) or any other national or regional code defining proper practices.** 



## GO™ Switch: Options L2/L4/Z2/Z4



### Calibration Procedure

Never perform switch calibration while an area is known to be hazardous.

For intrinsically safe models with L2/L4, the unit must be wired in accordance with the control drawing S-K127 and S-K127A.

For intrinsically safe models with Z2/Z4, the unit must be wired in accordance with the control drawing ES-01743-1 and ES-01744-1.

GO™ Switch calibration may be performed using a Volt-Ohm meter with the Ohm setting across COM and NO. When the switch is active, the meter will read  $\leq 0.5$  Ohms, or the Diode setting may be used simply to indicate continuity. If a 120VAC source is used, an appropriately sized resistor must be used in series to limit current to a maximum of 1.5 Amperes when circuit rating is unknown or permanent damage may occur.

### For L2/Z2 models mounted in parallel orientation

- Step 1:** With the valve CLOSED position. Push down and slide the target magnet #1 until SW1 activates. Release the target magnet to lock the position.
- Step 2:** Rotate the valve to the OPEN position. Push down and slide the target magnet #3 until SW3 activates. Release the target magnet to lock the position.
- Step 3:** Cycle the valve CLOSED and OPEN several times to ensure proper calibration.

### For L4/Z4 models mounted in parallel orientation

- Step 1:** With the valve CLOSED position. Push down and slide the target magnet #1 until SW1 activates. Release the target magnet to lock the position. Push down and slide the target magnet #3 until SW3 activates. Release the target magnet to lock the position.
- Step 2:** Rotate the valve to the OPEN position. Push down and slide the target magnet #2 until SW2 activates. Release the target magnet to lock the position. Push down and slide the target magnet #4 until SW4 activates. Release the target magnet to lock the position.
- Step 3:** Cycle the valve CLOSED and OPEN several times to ensure proper calibration

For models mounted in perpendicular orientation, the target disk will have to be rotated to realign the target disk to match the desired orientation.

- Step 1:** Grasp the target disk and gently lift until the target disk disengages the orientation pin in the shaft.
- Step 2:** Rotate the disk as needed to realign the targets. Use the images provided on the previous page as a reference.
- Step 3:** Follow steps 1 through 3 for models mounted in Parallel orientation above.

For reverse acting applications (Counterclockwise to close), the switch functions will be transposed. Sw 1 (and Sw 3 if in an L4/Z4 model) become open. Sw 2 (and Sw 4 if in an L4/Z4 model) become closed.

The "push to set" target disk has been designed to accommodate various applications and rotations. If your application is different from those outlined here, please consult the factory for further information.

### L2/L4 Specifications 3-1A

<b>Repeatability</b>	.002" (.05 mm)
<b>Response Time</b>	8 milliseconds
<b>Differential</b>	0.020 - .150" (0.5 - 3.8mm)
<b>Operating Temperature</b>	-60° to 221°F (-40° to 105°C)
<b>Contact Material</b>	Silver cadmium oxide, gold flashed
<b>Forms</b>	SPDT, Form C
<b>Ratings</b>	4A@120VAC / 2A@240VAC / 3A@24VDC
<b>Target Material</b>	Ferrous metal
<b>Sensing Range</b>	Approx. 1/10" (2.5 mm)

### Z2/Z4 Specifications 3-1B

<b>Repeatability</b>	.002" (.05 mm)
<b>Response Time</b>	8 milliseconds
<b>Differential</b>	0.020 - .150" (0.5 - 3.8mm)
<b>Operating Temperature</b>	-60° to 221°F (-40° to 105°C)
<b>Contact Material</b>	Palladium silver w/sawtooth surface configuration
<b>Forms</b>	DPDT, Form CC
<b>Ratings</b>	4A@120VAC / 2A@240VAC / 3A@24VDC / 0.5A@125VDC
<b>Target Material</b>	Ferrous metal
<b>Sensing Range</b>	Approx. .050 - .080" (1.3 - 2.0 mm)

Continued  
GO™ Switch: Options L2/L4/Z2/Z4

Electrical Connections & Wiring 3-1C

Option L2

Switch 1	
Green to GND	Ground
COM (Black)	Terminal 2
NO (Blue)	Terminal 3
NC (Red)	Terminal 1
Switch 3	
Green to GND	Ground
COM (Black)	Terminal 5
NO (Blue)	Terminal 6
NC (Red)	Terminal 4

Option L4

Switch 1		Switch 2	
Green to GND	Ground	Green to GND	Ground
COM (Black)	Terminal 2	COM (Black)	Terminal 5
NO (Blue)	Terminal 3	NO (Blue)	Terminal 6
NC (Red)	Terminal 1	NC (Red)	Terminal 4
Switch 3		Switch 4	
Green to GND	Ground	Green to GND	Ground
COM (Black)	Terminal 8	COM (Black)	Terminal 11
NO (Blue)	Terminal 9	NO (Blue)	Terminal 12
NC (Red)	Terminal 7	NC (Red)	Terminal 10

Option Z2

Switch 1			
Green to GND	Ground		
COM (Black)	Terminal 2	COM (Black/White)	Terminal 5
NO (Blue)	Terminal 3	NO (Blue/White)	Terminal 6
NC (Red)	Terminal 1	NC (Red/White)	Terminal 4
Switch 3			
Green to GND	Ground		
COM (Black)	Terminal 8	COM (Black/White)	Terminal 11
NO (Blue)	Terminal 9	NO (Blue/White)	Terminal 12
NC (Red)	Terminal 7	NC (Red/White)	Terminal 10

Option Z4

Switch 1				Switch 2			
Green to GND	Ground	Green to GND	Ground	Green to GND	Ground	Green to GND	Ground
COM (Black)	Terminal 2	COM (Black/White)	Terminal 5	COM (Black)	Terminal 14	COM (Black/White)	Terminal 17
NO (Blue)	Terminal 3	NO (Blue/White)	Terminal 6	NO (Blue)	Terminal 15	NO (Blue/White)	Terminal 18
NC (Red)	Terminal 1	NC (Red/White)	Terminal 4	NC (Red)	Terminal 13	NC (Red/White)	Terminal 16
Switch 3				Switch 4			
Green to GND	Ground	Green to GND	Ground	Green to GND	Ground	Green to GND	Ground
COM (Black)	Terminal 8	COM (Black/White)	Terminal 11	COM (Black)	Terminal 20	COM (Black/White)	Terminal 23
NO (Blue)	Terminal 9	NO (Blue/White)	Terminal 12	NO (Blue)	Terminal 21	NO (Blue/White)	Terminal 24
NC (Red)	Terminal 7	NC (Red/White)	Terminal 10	NC (Red)	Terminal 19	NC (Red/White)	Terminal 22

\* The above terminations are typical and may vary depending on your configuration. Refer to the wiring diagram located on the inside top housing for a wiring diagram specific to your configuration.

Terminal Strip Assembly

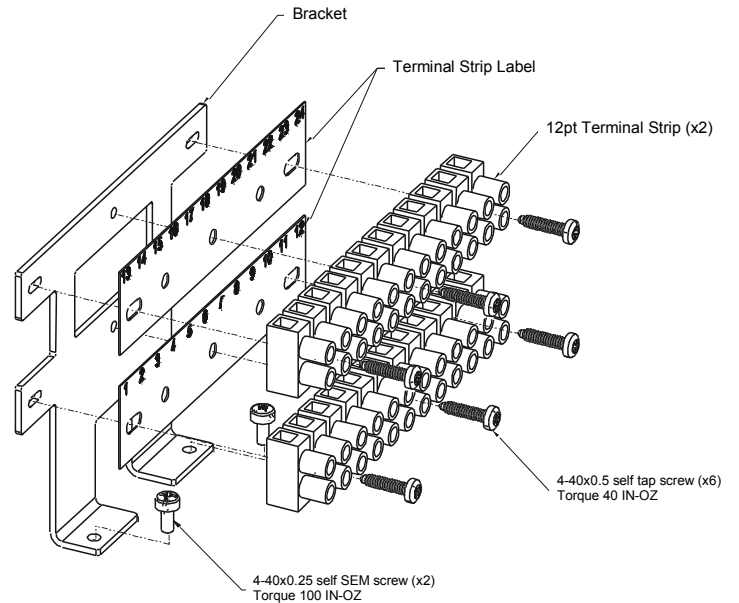

**NOTE:** Refer to the wiring diagram on the inside lid of your product to determine actual pin out location.

Continued  
**GO™ Switch: Options L2/L4/Z2/Z4**

**Target Arrangement**

All TopWorx™ products are factory set for 90° rotation normal acting on parallel orientation with switch 1 (full clockwise) for the process valve closed position. When changing orientation the target disk will have to be relocated for your application. All target disks are supplied with 4 slots on 90° increments allowing the TopWorx™ unit to be rotated 90°, 180°, or 270° from standard.

**TYPICAL L2/Z2 TARGET ARRANGEMENT**

MINIMUM USABLE ROTATION 45°  
 MAXIMUM USABLE ROTATION 125°

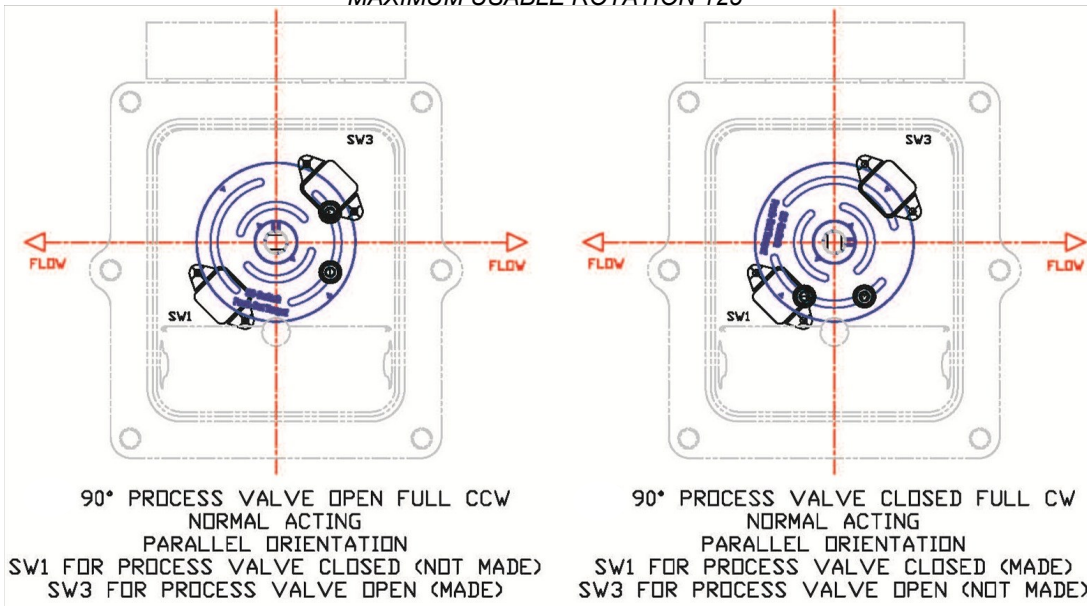

**TYPICAL L4/Z4 TARGET ARRANGEMENT**

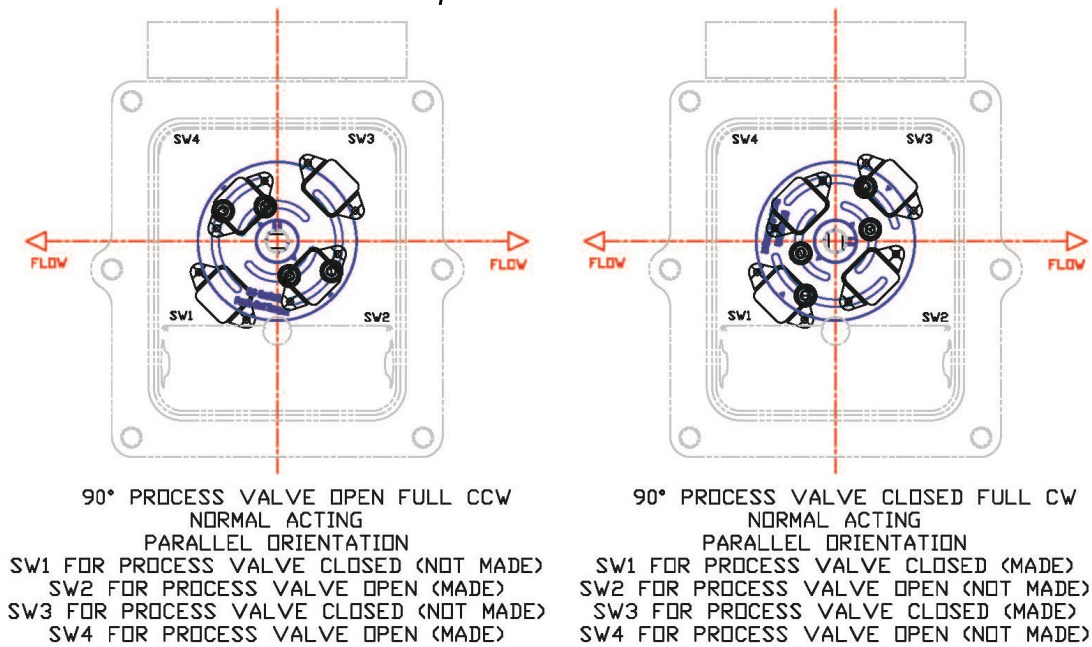

## Mechanical Switches: Options M2/M4/M6/K2/K4/K6/T2

### Calibration Procedure



Never perform switch calibration while an area is known to be hazardous. Calibration procedures for DPDT switches are the same as those for SPDT switches.

**Calibration may be performed** using a Volt-Ohm meter by using the Ohm setting across COM and NO. When the switch is active, the meter will read  $\leq 0.5$  Ohms, or the Diode setting may be used to indicate continuity.

**If a 120Vac source is used**, an appropriately sized resistor must be used in series to limit current to a maximum of 15 Amperes when circuit rating is unknown, or permanent damage may occur.

**Step 1:** With valve in the CLOSED position, disengage the BOTTOM cam from the splined Hub and rotate Clockwise until SW1 activates. Release cam to re-engage splined Hub.

**Step 2:** Rotate valve to the OPEN position. Disengage the TOP cam from the splined Hub and rotate Counter-clockwise until SW2 activates. Release cam to re-engage the splined Hub.

**Step 3:** Cycle valve CLOSED and OPEN several times to insure switches will maintain calibration.

#### For Reverse Acting actuators:

**Step 1:** With valve in the CLOSED position, disengage the TOP cam from the splined Hub and rotate Counter-clockwise until SW2 activates. Release cam to re-engage the splined Hub.

**Step 2:** Rotate valve to the OPEN position. Disengage the BOTTOM cam from the splined Hub and rotate Clockwise until SW1 activates. Release cam to re-engage the splined Hub.

Repeat Step 3 above.

\*When using the (4) and (6) switch options, use the same calibration steps as above for the switches you determine to indicate OPEN and which indicate CLOSED.

\*\*Switches may also be set at midpoint, or any point, of travel for Dribble Control, or any other logic necessary for the application.

### Mechanical Switch Assembly

#### Switch Option M2/K2/T2

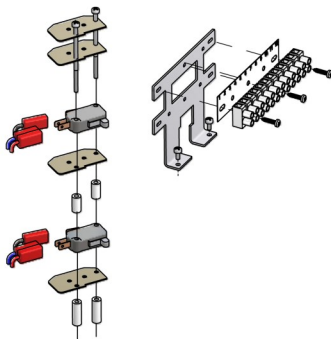

#### Switch Option M4/K4

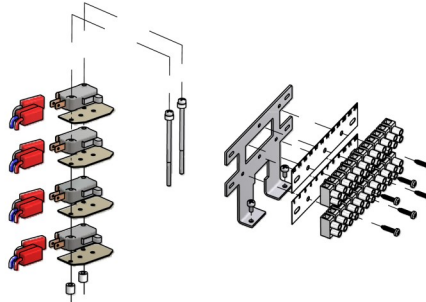

#### Switch Option M6/K6

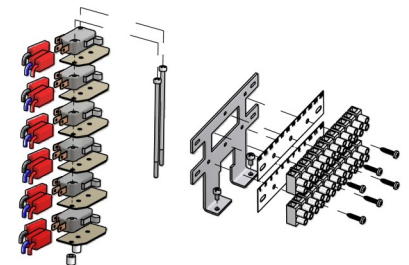

PRODUCT SPECIFICATIONS	
OPTION M	
Switch Type	Mechanical
Sealed	No
Circuitry	SPDT
Termination	Quick Connect
Rating	15A@125VAC or 250VAC
Conforming to standards	UL: 1054
Contact Resistance	15M $\Omega$ max. (initial)
Insulation Resistance	100M $\Omega$ min. (at 500V DC)
OPTION K	
Switch Type	Mechanical
Sealed	No
Circuitry	SPDT
Termination	Quick Connect
Rating	0.1A@125VAC MAX
Conforming to standards	UL: 1054

OPTION T	
Switch Type	Mechanical
Sealed	No
Circuitry	DPDT
Termination	Quick Connect
Rating	15A 125V AC or 250V AC
Conforming to standards	UL recognized and CSA certified, meets MIL-S-8805
Contact	Gold or silver
Terminals	End or side



Continued  
 Mechanical Switches: Options M2/M4/M6/K2/K4/K6/T2

Wiring Diagrams and Charts  
 Option M/K

Switch#	Connection	Color Code	Terminal#
1	NC	Red	1
	COM	Black	2
	NO	Blue	3
2	NC	Red/White	4
	COM	Black/White	5
	NO	Blue/White	6
3	NC	Yellow	7
	COM	Brown	8
	NO	Orange	9
4	NC	White/Yellow	10
	COM	White/Brown	11
	NO	White/Orange	12
5	NC	White	13
	COM	Gray	14
	NO	Violet	15
6	NC	Pink	16
	COM	White/Gray	17
	NO	White/Violet	18

Option T2

Switch#	Connection	Color Code	Terminal#
1	NC1	Red	1
	COM1	Black	2
	NO1	Blue	3
	NC2	Red/White	4
	COM2	Black/White	5
	NO2	Blue/White	6
2	NC1	Yellow	7
	COM1	Brown	8
	NO1	Orange	9
	NC2	White/Yellow	10
	COM2	White/Brown	11
	NO2	White/Orange	12



**NOTE:** Refer to the wiring diagram on the inside lid of your product to determine actual pin out location

## Inductive Sensors: Options E2/E4/E6

### Calibration Procedure



Never perform switch calibration while an area is known to be hazardous.

When installing a TopWorx™ product with P&F NAMUR sensors, use of a commercially available switch tester like P&F part# ST0-03 is suggested.

Calibration may be performed using a 24Vdc power supply.

**Step 1:** With valve in the CLOSED position, disengage the BOTTOM cam from the splined hub and rotate clockwise until SW1 activates. Release cam to re-engage splined hub.

**Step 2:** Rotate valve to the OPEN position. Disengage the TOP cam from the splined hub and rotate counter-clockwise until SW2 activates. Release cam to re-engage the splined hub.

**Step 3:** Cycle valve CLOSED and OPEN several times to insure switches will maintain calibration.

### For Reverse Acting actuators:

**Step 1:** With valve in the CLOSED position, disengage the TOP cam from the splined hub and rotate counter-clockwise until SW2 activates. Release cam to re-engage the splined hub.

**Step 2:** Rotate valve to the OPEN position. Disengage the BOTTOM cam from the splined hub and rotate clockwise until SW1 activates. Release cam to re-engage the splined hub.

Repeat Step 3 above.

\*When using the (4) and (6) switch options, determine which switches are to indicate OPEN and which indicate CLOSED and then use the same calibration steps as above.

\*\*Switches may also be set at midpoint, or any point, of travel for Dribble Control, or any other logic necessary for the application.

## P & F NJ2-V3-N Switch Assembly

Switch Option E2

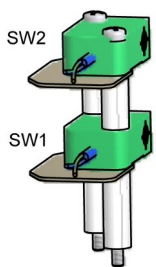

Switch Option E4

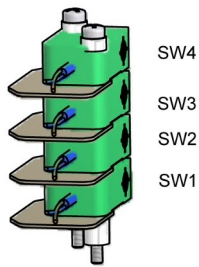

Switch Option E6

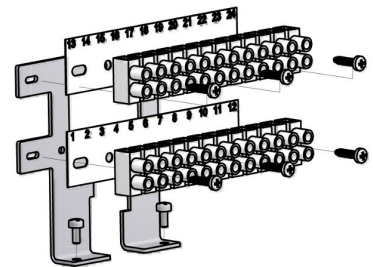
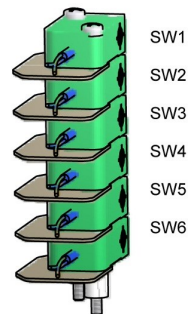

Continued  
**Inductive Sensors: Options E2/E4/E6**  
**Product Specifications**

<b>PRODUCT SPECIFICATIONS</b>	
<b>General specifications</b>	
Switching element function	NAMUR NC
Rated operating distance	s <sub>n</sub> 2 mm
Installation	embeddable
Output polarity	NAMUR
Assured operating distance	s <sub>a</sub> 0 ... 1.62 mm
Reduction factor r <sub>A</sub>	0.25
Reduction factor r <sub>Cu</sub>	0.2
Reduction factor r <sub>V2A</sub>	0.7
<b>Nominal ratings</b>	
Nominal voltage	U <sub>o</sub> 8 V
Switching frequency	f 0 ... 1000 Hz
Hysteresis	H typ. %
Current consumption	
Measuring plate not detected	≥3 mA
Measuring plate detected	≤1 mA
<b>Standard conformity</b>	
EMC in accordance with	IEC / EN 60947-5-2:2004
Standards	DIN EN 60947-5-6 (NAMUR)
<b>Ambient conditions</b>	
Ambient temperature	-25 ... 100 °C (248 ... 373 K)
<b>Mechanical specifications</b>	
Connection type	0.1m, PVC cable
Core cross-section	0.14 mm <sup>2</sup>
Housing material	PBT
Sensing face	PBT
Protection degree	IP67
<b>General information</b>	
Use in the hazardous area	see instruction manuals
Category	1G; 2G; 1D

**Wiring Chart**

<b>LEAD WIRE TERMINATIONS CHART</b>		
<b>SWITCH #</b>	<b>LEAD COLOR</b>	<b>TERMINAL#</b>
1	BROWN +	1
	BLUE -	2
2	BROWN +	3
	BLUE -	4
3	BROWN +	5
	BLUE -	6
4	BROWN +	7
	BLUE -	8
5	BROWN +	9
	BLUE -	10
6	BROWN +	11
	BLUE -	12



**NOTE:** Refer to the wiring diagram on the inside lid of your product to determine actual pin out location

## Continued Inductive Sensors: Options V2/V4

### P & F NJ3-18GK-S1N

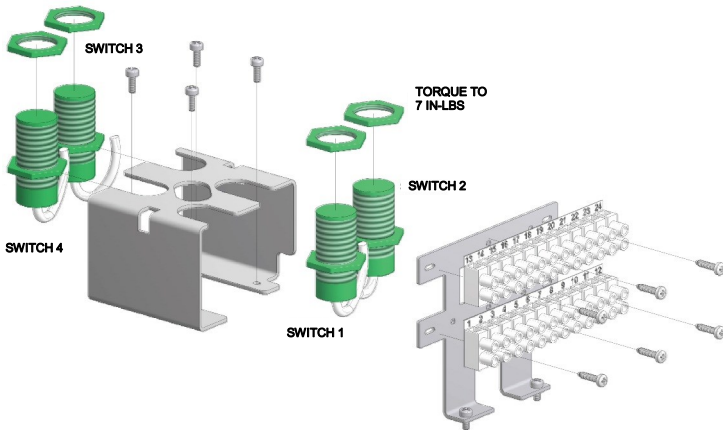

### Calibration Procedure

Never perform switch calibration while an area is known to be hazardous.



For intrinsically safe models, the unit must be wired in accordance with the control drawing ES-00210-1.

PRODUCT SPECIFICATIONS	
<b>General specifications</b>	
Switching element function	NAMUR NO
Rated operating distance	3 mm
Installation	Embed in mild steel
Output polarity	Safety Function
Assured operating distance	0 ... 2.44 mm
Reduction factor rAl	1
Reduction factor rCu	1
Reduction factor rV2A	0
<b>Nominal ratings</b>	
Nominal voltage	8 V
Switching frequency	0 ... 200 Hz
Hysteresis	typ. 0.1%
<b>Current consumption</b>	
Measuring plate not detected	≤ 1mA
Measuring plate detected	≥ 3mA
<b>Ambient conditions</b>	
Ambient temperature	-25 ... 100 °C
<b>Mechanical specifications</b>	
Connection type	2m Silicone cable
Core cross section	0.75mm <sup>2</sup>
Housing material	Hostalen PPN, black
Sensing face	Hostalen PPN, black
Protection degree	IP68
Note	Only for non-ferrous metal
<b>General information</b>	
Use in the hazardous area	see instruction manuals
Category	1G; 2G; 3G; 1D

When installing a TopWorx™ product with P&F NAMUR sensors, use of a commercially available switch tester like P&F part# ST0-03 is suggested.

Calibration may be performed using a 24Vdc power supply.

#### For V2 models mounted in parallel orientation

- Step 1:** With the valve CLOSED position. Push down and slide the target magnet #1 until SW1 activates. Release the target magnet to lock the position.
- Step 2:** Rotate the valve to the OPEN position. Push down and slide the target magnet #3 until SW3 activates. Release the target magnet to lock the position.
- Step 3:** Cycle the valve CLOSED and OPEN several times to ensure proper calibration.

#### For V4 models mounted in parallel orientation

- Step 1:** With the valve CLOSED position. Push down and slide the target magnet #1 until SW1 activates. Release the target magnet to lock the position. Push down and slide the target magnet #3 until SW3 activates. Release the target magnet to lock the position.
- Step 2:** Rotate the valve to the OPEN position. Push down and slide the target magnet #2 until SW2 activates. Release the target magnet to lock the position. Push down and slide the target magnet #4 until SW4 activates. Release the target magnet to lock the position.
- Step 3:** Cycle the valve CLOSED and OPEN several times to ensure proper calibration

For models mounted in perpendicular orientation, the target disk will have to be rotated to realign the target disk to match the desired orientation.

- Step 1:** Grasp the target disk and gently lift until the target disk disengages the orientation pin in the shaft.
- Step 2:** Rotate the disk as needed to realign the targets.
- Step 3:** Follow steps 1 through 3 for models mounted in Parallel orientation above.

For reverse acting applications (CCW to close), the switch functions will be transposed. Sw 1 (and Sw 3 if in an V4 model) become open. Sw 2 (and Sw 4 if in an V4 model) become closed.

The "push to set" target disk has been designed to accommodate various applications and rotations. If your application is different from those outlined here, please consult the factory for further information.



**Continued**  
**Inductive Sensors : Options V2/V4**

**Target Arrangement**

All TopWorx™ products are factory set for 90° rotation normal acting on parallel orientation with switch 1 (full clockwise) for the process valve closed position

When changing orientation the target disk will have to be relocated for your application. All target disks are supplied with 4 slots on 90° increments allowing the TopWorx™ unit to be rotated 90°, 180°, or 270° from standard.

**TYPICAL V2 TARGET ARRANGEMENT**

*MINIMUM USABLE ROTATION 45°  
 MAXIMUM USABLE ROTATION 125°*

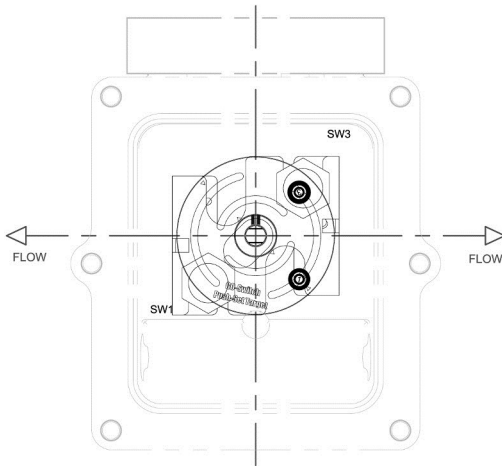

V2 90° PROCESS VALVE OPEN FULL CCW  
 NORMAL ACTING  
 PARALLEL ORIENTATION  
 SW1 FOR PROCESS VALVE CLOSED (NOT MADE)  
 SW3 FOR PROCESS VALVE OPEN (MADE)

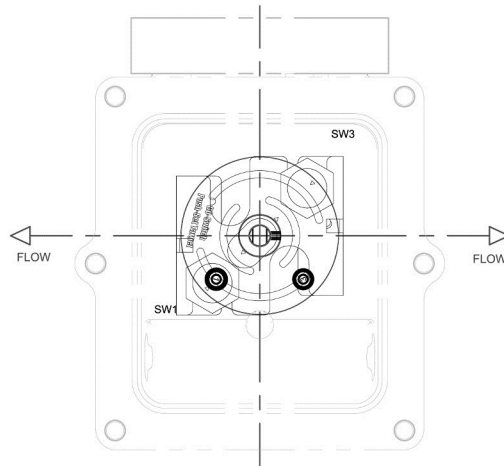

V2 90° PROCESS VALVE CLOSED FULL CW  
 NORMAL ACTING  
 PARALLEL ORIENTATION  
 SW1 FOR PROCESS VALVE CLOSED (MADE)  
 SW3 FOR PROCESS VALVE OPEN (NOT MADE)

**TYPICAL V4 TARGET ARRANGEMENT**

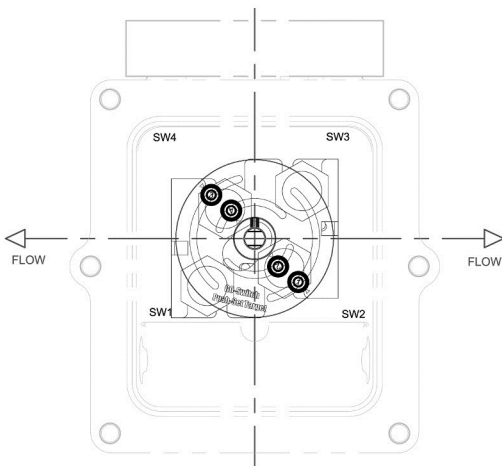

V4 90° PROCESS VALVE OPEN FULL CCW  
 NORMAL ACTING  
 PARALLEL ORIENTATION  
 SW1 FOR PROCESS VALVE CLOSED (NOT MADE)  
 SW2 FOR PROCESS VALVE OPEN (MADE)  
 SW3 FOR PROCESS VALVE CLOSED (NOT MADE)  
 SW4 FOR PROCESS VALVE OPEN (MADE)

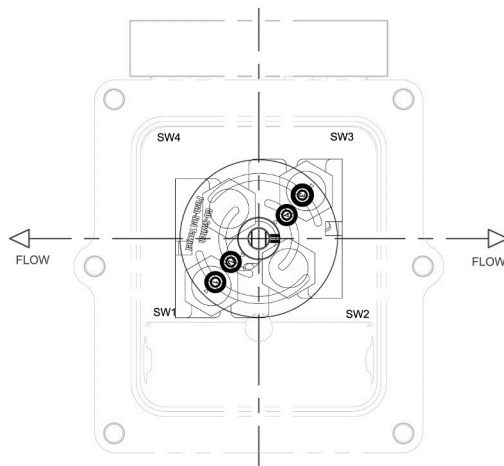

V4 90° PROCESS VALVE CLOSED FULL CW  
 NORMAL ACTING  
 PARALLEL ORIENTATION  
 SW1 FOR PROCESS VALVE CLOSED (MADE)  
 SW2 FOR PROCESS VALVE OPEN (NOT MADE)  
 SW3 FOR PROCESS VALVE CLOSED (MADE)  
 SW4 FOR PROCESS VALVE OPEN (NOT MADE)

## 4-20mA Transmitter: Options LX/MX/KX/EX/TX/ZX/OX

The 2-wire 4-20mA transmitter will generate a nominal 4 – 20mA output for full-range actuation of the valve. The transmitter is capable of generating signals below 4mA and above 20mA if the position sensor indicates an out of range value.

### Features:

- 1) Single push button easy calibration eliminates zero/span calibration interaction in both clockwise and counterclockwise actuator/valve rotation directions.
- 2) Non-volatile memory of set points (set points remain after loss of power)
- 3) 4-20mA power connection is not polarity sensitive
- 4) No internal backlash – direct shaft position feedback
- 5) No gear wear or mechanical binding
- 6) Small package size for easier access to limit switch cams. The small packaging allows for additional options that can be mounted in the valve monitoring enclosure
- 7) Position measurement range from 20° to 320°. Factory set for 20° to 180° operation in counter clockwise rotation to open and 20° to 90° operation in clockwise rotation to open applications.
- 8) Advanced diagnostics includes detection of dead band, out of range indication and detection of internal memory errors
- 9) Transmitter PCB is potted and sealed
- 10) Included with all valve monitoring switching options, incl. DPDT mechanical
- 11) +/- 1% position linearity for the complete device
- 12) Selectable +/- 3% over and under travel capability or full linear options set during calibration
- 13) Hysteresis: 0.5% of full-scale
- 14) Repeatability: 0.3% of full scale
- 15) Temperature Range: -40° to 85°C

### Potentiometer Only Shaft Position Monitoring Description

The potentiometer only version (without the 4-20mA Position Transmitter Module) will generate a ratio metric voltage output based on the excitation voltage and the position of the valve. Standard potentiometer options include 0-1k ohm and 0-10k ohm.

### Potentiometer Features

- Hollow shaft mounting requires no gears and has no backlash
- Direct shaft position feedback
- Capable of 4,000,000 lifetime operations
- Better than 0.3° resolution
- Conductive plastic Potentiometric sensor
- for environmental protection
- Temperature Range: -40° to +85°C

### Potentiometer Electrical Data

- Voltage Input Range: 0-35 Volts
- Actual Electrical Travel 340° (dead band of 20°)
- Current Maximum: 3mA
- Recommended operating wiper current is less than or equal to 1 micro amp (recommend using the wiper voltage to drive an operational amplifier working as a voltage follower in which a very small load is applied to the wiper)
- Independent Linearity ±2%
- Resistance Tolerance ±20%

### Electrical Data

- Voltage Input Range: 8.5 - 34 Volts DC
- Standard Output Signal: Two wire 4-20mA with out of range indication
- Input Polarity: Bi-Directional

### Potentiometer Wiring

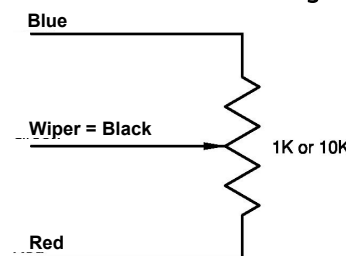

**NOTE:** Refer to the wiring diagram on the inside lid of your product to determine actual pin out location

Continued  
 4-20mA Transmitter: Options LX/MX/KX/EX/TX/ZX/OX

Calibration Flow Chart

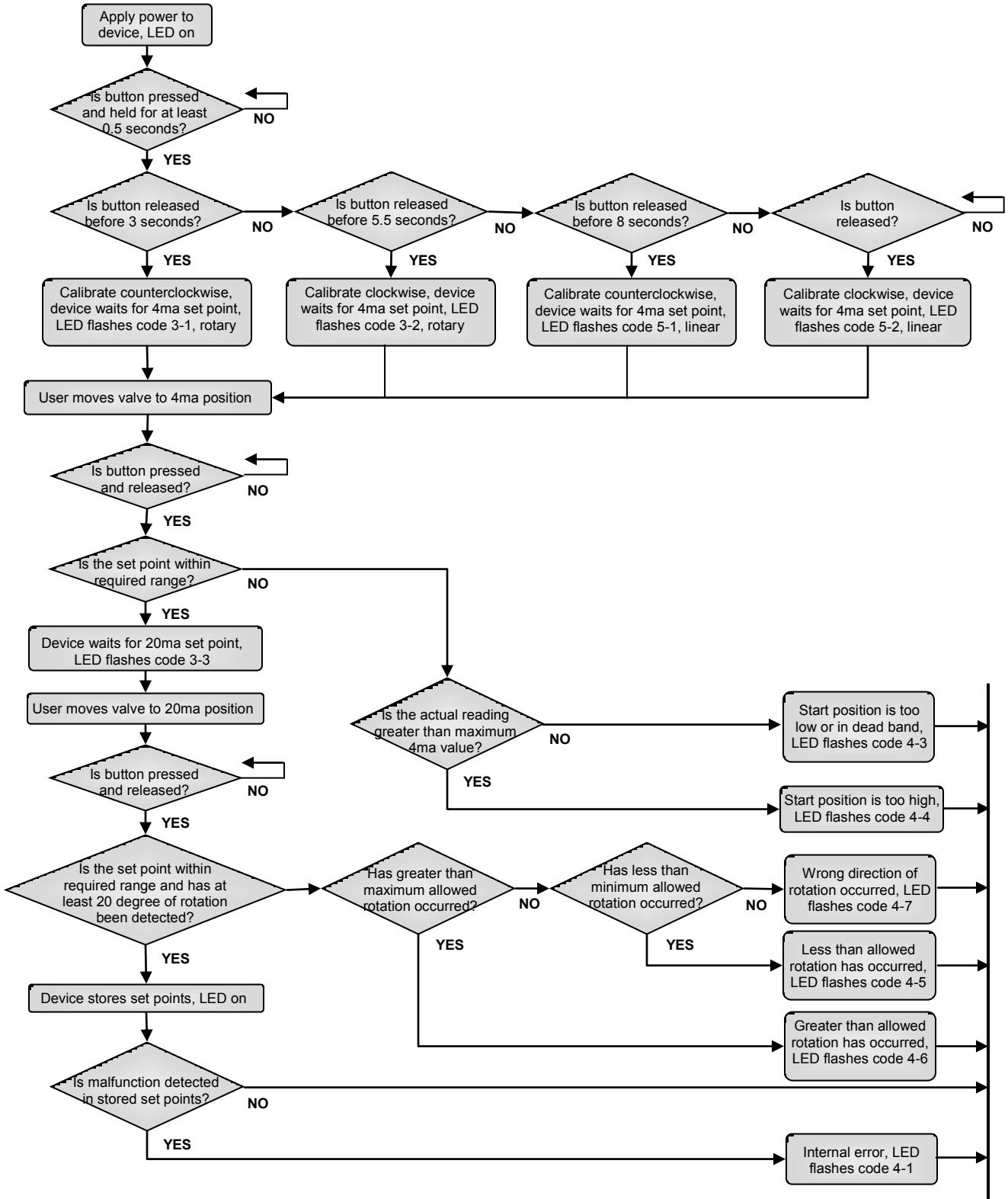

## Continued

### 4-20mA Transmitter: Options LX/MX/KX/EX/TX/ZX/OX

#### Troubleshooting Error Code and Problem Table

Problem	Probable Cause/Solution
Transmitter Module has no current output	If the LED on the Transmitter Module is not lit - Loose or shorted signal connection (fix connection) - Controller Board not responding (Replace Transmitter Module)  If the LED on the Circuit Board is lit - Potentiometer is disengaged from shaft (must be returned for repair) - Defective controller board (Replace Transmitter Module)
Transmitter does not output 4 or 20mA (+/-1%) at desired end of travel	Unit not calibrated (calibrate) Unit is calibrated (recalibrate - if still fails, replace board)
Output is not linear or does not track valve position or rotation	Input signal is not linear - Linkage or drive mechanism is introducing non-linearity - Unit is not calibrated (calibrate)
Error Code 4-3	Start position is too low or in the dead-band position.
Error Code 4-4	Start Position is too high
Error Code 4-5	Start and stop positions are less than 20°, increase valve rotation between start and stop positions to greater than 20°.
Error Code 4-6	Rotation has exceeded the 320° limit. Decrease valve rotation between start and stop positions to less than 320°.
Error Code 4-7	Calibration rotation was in the wrong direction or the potentiometer passed through the dead-band position.
Error Code 4-1	Internal Error has occurred. Recalibrate, if error continues, replace module.

#### LED Flash Code Diagram

Flash Codes ( first count – second count )	Interpretations
0-0	Calibrated
3-1	Counter-Clockwise Calibration, Waiting to calibrate the 4mA position, Rotary Mode
3-2	Clockwise Calibration, Waiting to calibrate the 4mA position, Rotary Mode
3-3	Waiting for 20mA Full Open Setting Button Press
4-1	Calibration Required
4-3	Calibration Start Value is Too Low
4-4	Calibration Start Value is Too High
4-5	End Value is Too Close to Start Value
4-6	Maximum Rotation Exceeded
4-7	Wrong Direction of Rotation
5-1	Counter-Clockwise Calibration, Waiting to calibrate the 4mA position, Linear Mode
5-2	Clockwise Calibration, Waiting to calibrate the 4mA position, Linear Mode

#### Operation of the 4-20mA Current Position Transmitter

During run mode, the 4-20mA position transmitter will output 4-20mA for valve positions between and including the set points. The module has an optional over or under travel correction if the valve position exceeds the high or low set point by +/-3%. In other words, the output will be 4mA for +/-3% over and under travel on the low end and 20mA for +/-3% over and under travel on the high end. If the valve position exceeds 3% of over travel then values below 4mA or above 20mA will be output. The user selectable other option is to calibrate the device without the over and under travel capability. See the calibration procedure in this document for additional information.

#### Operation of the Stand Alone Potentiometer

The potentiometer only version will generate a ratio metric voltage output based on the excitation voltage and the position of the valve. Standard potentiometer options include 0-1k ohm and 0-10k ohm.



## Continued

### 4-20mA Transmitter: Options LX/MX/KX/EX/TX/ZX/0X

### D-Series Upgrade Procedure: 4-20mA Position Transmitter

#### (Use the following installation procedure to upgrade an existing D-Series in the field)

Typically the 4-20mA Position Transmitter module and potentiometer options are already installed in TopWorx™ valve controller products. Use the following installation directions only if you are replacing or upgrading an existing unit:

- 1) First remove the valve monitor enclosure from the valve/actuator
- 2) Install the 4-20mA position transmitter using the supplied or existing mounting bolts (See illustration below)
- 3) Remove the existing shaft and replace with the new shaft and position sensor kit assembly (See illustration below)
  - a) Remove circlip and washer from shaft on bottom of enclosure (outside)
  - b) Pull shaft out gently from top side of enclosure
  - c) Install lube (from packet) on new shaft just below potentiometer and spread around O-ring seals on shaft
- 4) The alignment boss on the bracket (indicated in the illustration below) should hold one of the mounting ears of the sensor in place. Once mounted, verify that no rotary movement of the potentiometer housing is possible
- 5) If applicable, plug the position sensor cable into the 4-20mA position transmitter keyed header connector
- 6) Connect the three output wires to the indicated terminal block positions if you are using the potentiometer only option.
- 7) The module is now ready for calibration/operation
- 8) Before mounting the DXP to an actuator, make sure the potentiometer alignment marks are aligned as shown in the illustration below with the valve in the closed position.

The potentiometer has been factory set for typical valve rotation ranges from 2° to 180° in counter-clockwise rotation applications from the 4mA position to the 20mA position and from valve rotation ranges from 2° to 90° in clockwise rotation applications from the 4mA position to the 20mA position. Please contact TopWorx™ for proper potentiometer set up for ranges greater than specified above.



#### Module and Bracket

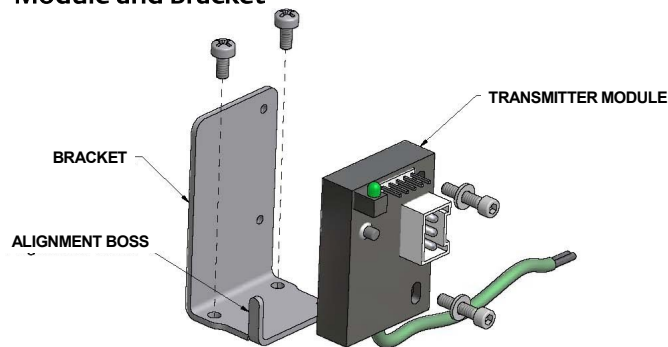

#### Potentiometer Shaft Assembly

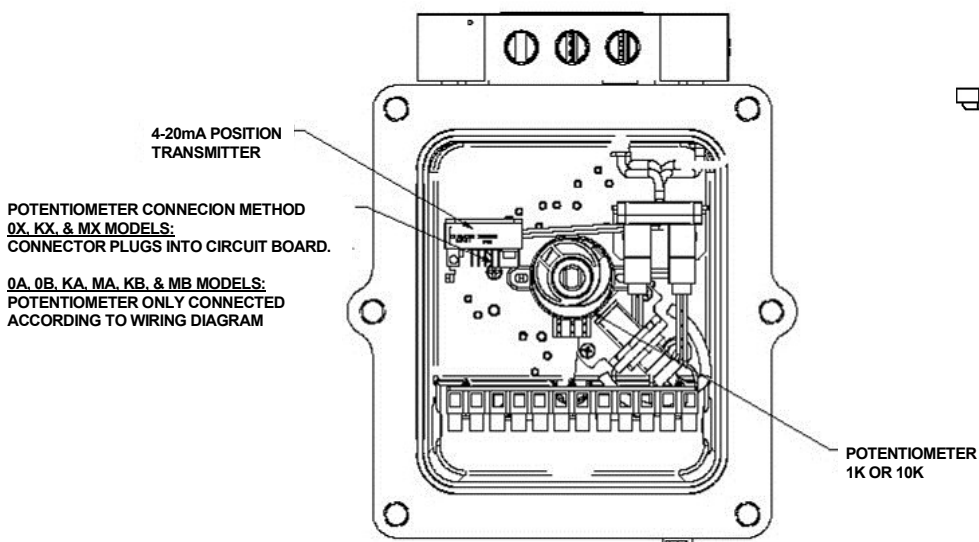
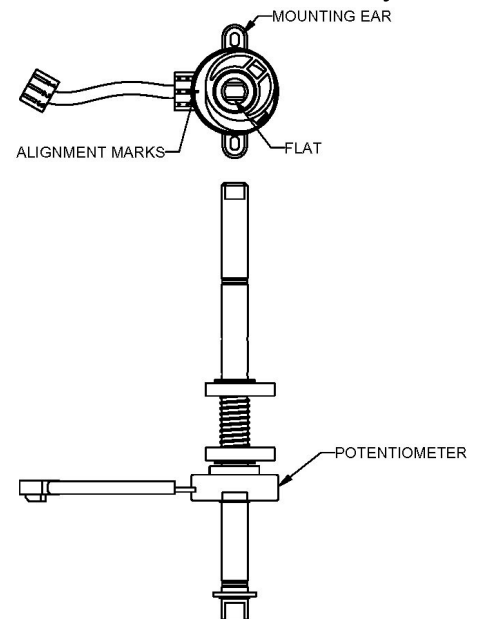

## Continued

### Features and Specifications

#### 4-20mA Position with HART Protocol

The 2-wire 4-20mA transmitter with HART will generate a nominal 4-20mA proportional to valve position output for full-range actuation of the valve. The transmitter is capable of generating signals below 4mA and above 20mA if the position sensor indicates an out of range value. With the added HART digital communication capability, remote calibration and parameter configuration can be performed.

#### Features:

- 1) Single push button easy calibration eliminates zero/span calibration interaction in both clockwise and counterclockwise actuator/valve rotation directions
- 2) Non-volatile memory of set points (set points remain after loss of power)
- 3) No internal backlash – direct shaft position feedback
- 4) No gear wear or mechanical binding
- 5) Position measurement range from 20 to 320 degrees. Factory set for 20 to 180 degrees operation in counter clockwise rotation to open and 20 to 90 degrees operation in clockwise rotation to open applications
- 6) Advanced diagnostics includes detection of dead band, out of range indication
- 7) Transmitter PCB is potted and sealed from the environment
- 8) Selectable +/- 3% over and under travel capability or full linear options set during calibration

#### HART Features:

- 1) Remote set point calibration  
– Example: Using a handheld device for calibration and monitoring
- 2) 4 to 20mA variable reading (PV)
- 3) Valve opening indication in percentage
- 4) Setting the range of the process variable
- 5) Monitoring and setting of alarms with advanced diagnostics. Includes detection of deadband, out of range indication
- 6) Selectable +/- 3% over and under travel capability (rotary) or full linear options"
- 7) Multi-drop functionality
- 8) Easy integration into AMS and DeltaV systems
- 9) DD files registered through HCF (HART Communication Foundation)

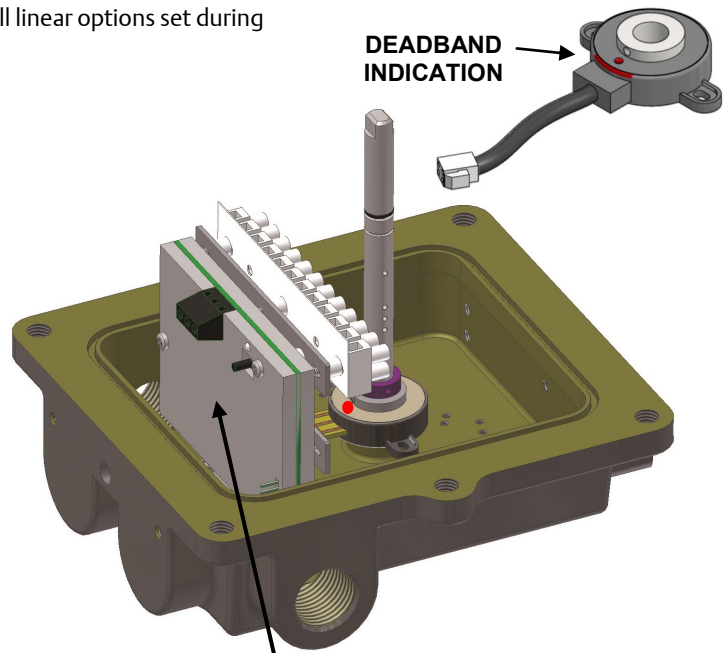

Typical HART device in a TopWorx™ DXP

Maximum Voltage	39.0 VDC
Linearity (Absolute, Full Scale)	+/- 2% of output span
Repeatability (Full Scale)	0.3% of full scale.
Hysteresis	0.3% of full scale
Temperature Range	-40° C to 80° C
Input Polarity Protection	No dmg occurs from reversal of loop current

#### Electrical Data:

- Voltage Input Range: 15 - 39 Volts DC
- Standard Output Signal: Two wire 4-20mA with out of range indication

## Continued

### 4-20mA Transmitter with HART: Options LH/MH/KH/EH/ZH/OH

During run mode, the 4-20mA position transmitter will output 4-20mA for valve positions between and including the set points. In the rotary mode, the module will provide an over or under travel correction if the valve position exceeds the high or low set point within +/-3% . In other words, the output will be 4mA for +/-3% over and under travel on the low end and 20mA for +/-3% over and under travel on the high end. If the valve position exceeds 3% of over travel, then values below 4mA or above 20mA will be output. In the linear mode, no under or over travel is compensated for. The device can be set to either linear or rotary mode during calibration using the on board push button switch, or remotely using HART communications.

#### Calibrating End Set Points Locally:

The 4-20 current transmitter can be used for any rotation range between 20 and 320 degrees\*\*.

##### Option #1: +/- 3% Over and Under Travel at the Set End Points (Rotary):

- 1) As the shaft rotates, make sure the potentiometer is not rotating through its deadband area. The red dot located on the potentiometer should not rotate past the area marked with red during the full rotation of the valve. If it does, reposition the shaft.
- 2) Apply power to unit (LED should be continuously on to indicate the unit has been calibrated or flashing the 4-1 code to indicate the unit has not been calibrated)
- 3) **Counter-clockwise calibration** - Press the button greater than 0.5 seconds and less than 3 seconds if you are going to calibrate using a counter-clockwise rotation from the 4mA position to the 20mA position. (LED will start flashing a 3-1 code indicating that calibration mode is active and the unit is waiting to calibrate the 4ma position).
- 4) **Clockwise calibration** - Press the button greater than 3 seconds and less than 5.5 seconds if you are going to calibrate using a clockwise rotation from the 4mA position to the 20mA position. (LED will start flashing a 3-2 code indicating that calibration mode is active and the unit is waiting to calibrate the 4mA position).
- 5) Rotate valve to the desired position corresponding to 4mA. (This can be the open or closed position)
- 6) Press the button to capture the 4mA value (The LED will start flashing a 3-3 code indicating that the unit is waiting to calibrate the 20mA position)
- 7) Rotate valve to the desired position corresponding to 20mA (This will be the position opposite of the position in step 3 or step 4)
- 8) Press the button to capture the 20mA value (The LED will turn on continuously)

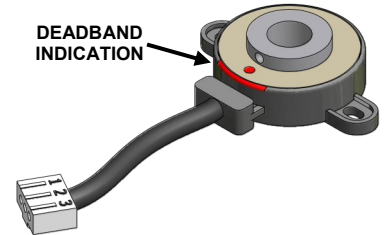

##### Option #2: No Under and Over Travel at Set End Points (Full Linear):

- 1) As the shaft rotates, make sure the potentiometer is not rotating through its dead band area. The red dot located on the potentiometer should not rotate past the area marked with red during the full rotation of the valve. If it does, reposition the shaft.
- 2) Apply power to unit (LED should be continuously on to indicate the unit has been calibrated or flashing the 4-1 code to indicate the unit has not been calibrated)
- 3) **Counter-clockwise calibration** - Press the button greater than 5.5 seconds and less than 8 seconds if you are going to calibrate using a counter-clockwise rotation from the 4mA position to the 20mA position. (LED will start flashing a 5-1 code indicating that calibration mode is active and the unit is waiting to calibrate the 4mA position).
- 4) **Clockwise calibration** - Press the button greater than 8 seconds if you are going to calibrate using a clockwise rotation from the 4mA position to the 20mA position. (LED will start flashing a 5-2 code indicating that calibration mode is active and the unit is waiting to calibrate the 4mA position).
- 5) Rotate valve to the desired position corresponding to 4mA. (This can be the open or closed position)
- 6) Press the button to capture the 4mA value (The LED will start flashing a 3-3 code indicating that the unit is waiting to calibrate the 20mA position)
- 7) Rotate valve to the desired position corresponding to 20mA (This will be the position opposite of the position in step 3 or step 4)
- 8) Press the button to capture the 20mA value (The LED will turn on continuously)

NOTE:\*\*The potentiometer has been factory set for typical valve rotation ranges from 20 to 180 degrees in counter-clockwise rotation applications from the 4mA position to the 20mA position and from valve rotation ranges from 20 to 90 degrees in clockwise rotation applications from the 4mA position to the 20mA position. Please contact TopWorx™ for proper potentiometer set up for ranges greater than specified above.

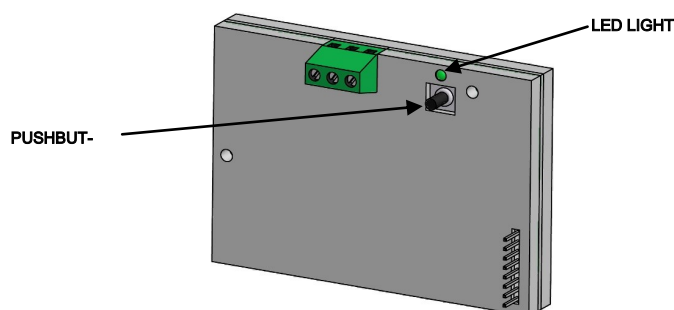

**NOTE:** Schematics are for illustration purposes only. Refer to the wiring diagram on your product to determine actual pin out location

Continued  
 4-20mA Transmitter with HART: Options LH/MH/KH/EH/ZH/OH  
 Calibration Chart

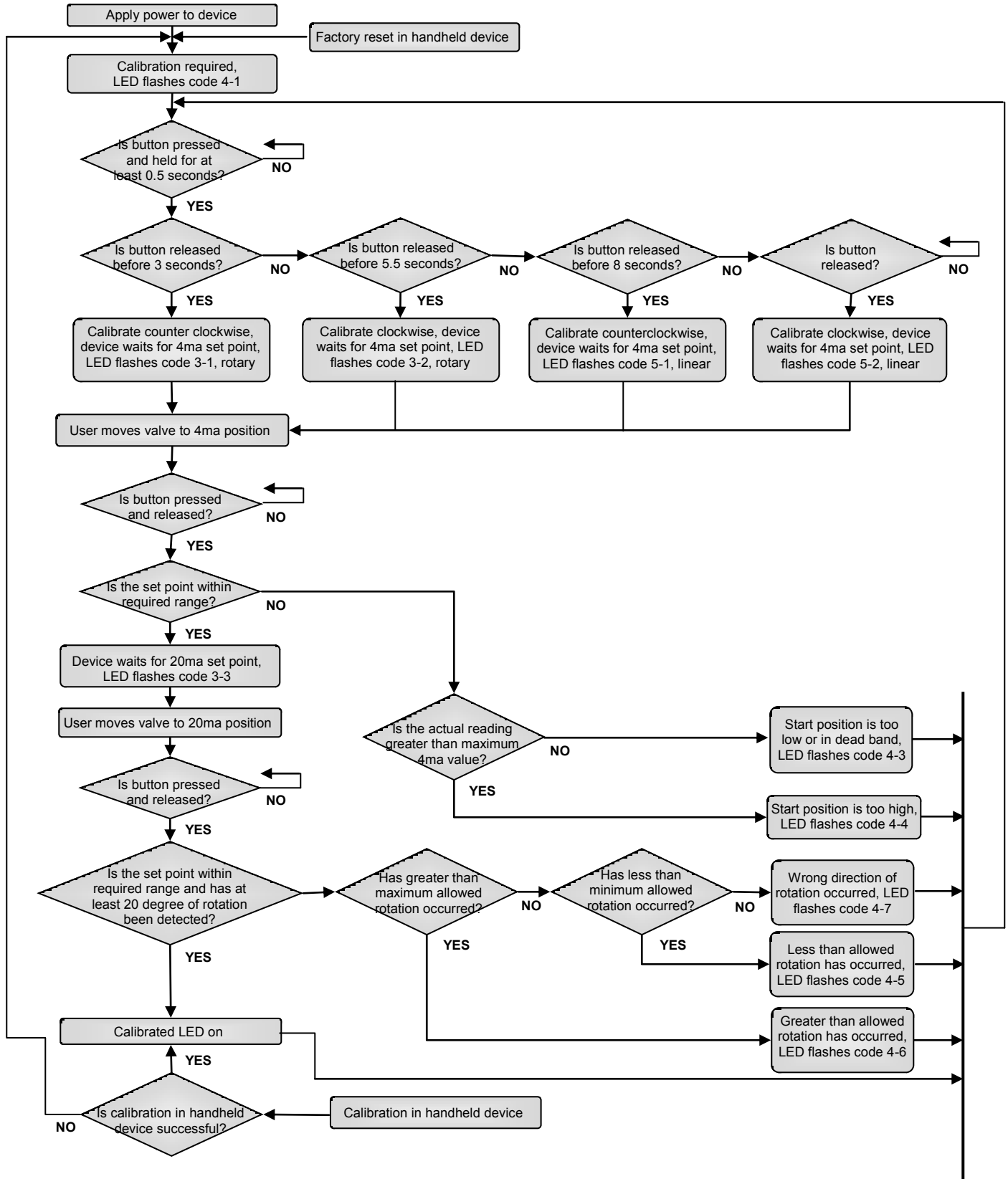

## Continued

### 4-20mA Transmitter with HART: Options LH/MH/KH/EH/ZH/OH Remote HART calibration using the Emerson 375 Field Communicator

- 1) Make sure that the HART power is not activated before attaching the signal/power wires, wires must be 12 to 24 AWG, to the HART device.
- 2) If not already connected, connect the device to the two HART signal/power lines. Pin 1 on the terminal block is the positive input and pin 2 is the negative input. Pin 1 is the first pin on the left of the module and pin 2 is the middle pin (see picture below). Once connected, activate the HART power/signal from the control system.

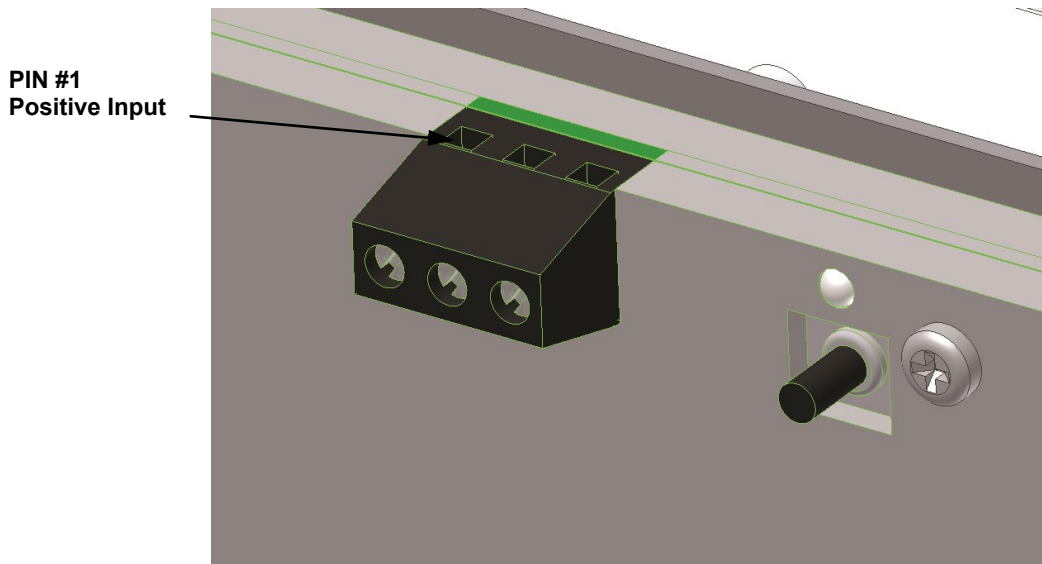

- 3) Connect the Emerson 375 Handheld device to the HART signal lines. Red marked lead to the positive signal line and the black lead to the negative signal line.
- 4) Activate the 375.
- 5) Select the HART Application option from the menu selections.
- 6) If a warning screen is shown. Disregard and hit "CONTINUE".
- 7) If the "Modification has been made to the configuration" screen is shown, hit "OK".
- 8) ANYTIME the non-zero status code(s) screen is shown, hit "YES".  
The main menu should now be shown indicating:
  - Process Variable
  - Device Service
  - Review
- 10) Select the "2. Device Service" option.
- 11) Select the "5. Calibrate" option.
- 12) Select "OK" when the "You are to set the valve operation ranges" screen is shown.
- 13) Select either the "1. Counter clockwise" or "2. Clockwise" options depending on the application.
- 14) Make sure the potentiometer is not rotating through its deadband area.
- 15) Follow the on screen instructions. Select "OK" when the valve is at the 4mA setpoint (Is the valve fully closed?)
- 16) After the first set point is saved, rotate the valve to the 20mA position.
- 17) Select "OK".
- 18) The set points are now calibrated.
- 19) If error occurs, the screen will display the error type and abort.
- 20) Re-calibrate if an error occurs and again make sure the potentiometer is not rotating through its deadband area.

Continued  
 4-20mA Transmitter with HART: Options LH/MH/KH/EH/ZH/OH  
 HART DD Menu Tree (Emerson 375 Field Communicator)

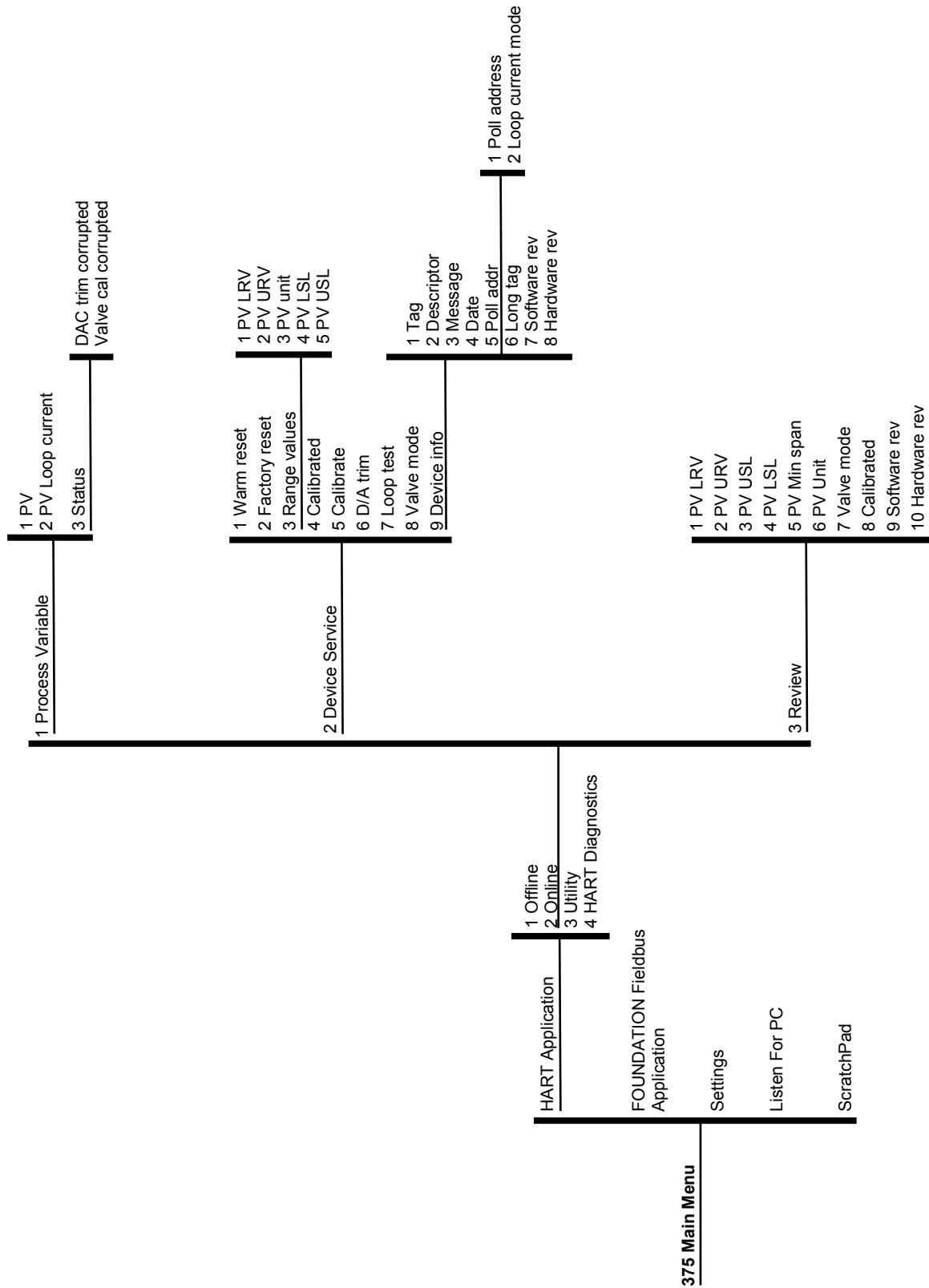

Continued  
 4-20mA Transmitter with HART: Options LH/MH/KH/EH/ZH/OH  
 Troubleshooting

LED Flash Code Diagram

Flash Codes (first count-second count)	Interpretations
0-0	Calibrated
3-1	Counter-Clockwise Calibration, Waiting to calibrate the 4mA position, Rotary Mode
3-2	Clockwise Calibration, Waiting to calibrate the 4mA position, Rotary Mode
3-3	Waiting for 20mA Full Open Setting Button Press
4-1	Calibration Required
4-3	Calibration Start Value is Too Low
4-4	Calibration Start Value is Too High
4-5	End Value is Too Close to Start Value
4-6	Maximum Rotation Exceeded
4-7	Wrong Direction of Rotation
5-1	Counter-Clockwise Calibration, Waiting to calibrate the 4mA position, Linear Mode
5-2	Clockwise Calibration, Waiting to calibrate the 4mA position, Linear Mode

LED Error Codes

Problem	Probable Cause Solution
Transmitter Module has no current output	<p>If the LED on the Transmitter Module is not lit</p> <ul style="list-style-type: none"> <li>- Loose or shorted signal connection (fix connection)</li> <li>- Controller Board not responding (Replace Transmitter Module)</li> </ul> <p>If the LED on the Circuit Board is lit</p> <ul style="list-style-type: none"> <li>- Potentiometer is disengaged from shaft (must be returned for repair)</li> <li>- Defective controller board (Replace Transmitter Module)</li> </ul>
Transmitter does not output 4 or 20mA (+/-1%) at desired end of travel	<p>Unit not calibrated (calibrate)</p> <p>Unit is calibrated (recalibrate - if still fails, replace board)</p>
Output is not linear or does not track valve position or rotation	<p>Input signal is not linear</p> <ul style="list-style-type: none"> <li>- Linkage or drive mechanism is introducing non-linearity</li> <li>- Unit is not calibrated (calibrate)</li> </ul>
Error Code 4-3	Start position is too low or in the dead-band position.
Error Code 4-4	Start Position is too high
Error Code 4-5	Start and stop positions are less than 20°, increase valve rotation between start and stop positions to greater than 20°.
Error Code 4-6	Rotation has exceeded the 320° limit. Decrease valve rotation between start and stop positions to less than 320°.
Error Code 4-7	Calibration rotation was in the wrong direction or the potentiometer passed through the dead-band position.
Error Code 4-1	Internal Error has occurred. Recalibrate, if error continues, replace module.



## D2-FF Discrete Valve Controller Description & Specification

The TopWorx™ D2-FF Discrete Valve Controller combines position sensing and monitoring with FOUNDATION Fieldbus communications and pilot valve output drivers. It incorporates the following features:

### FOUNDATION Fieldbus digital communication:

- Link active scheduler capability/Link Master (LAS)
- Pre-instantiated\*\* blocks include Resource Block (RB), Transducer Block (TB), Analog Input (AI) Function Block, Discrete Output (DO) Function Block, 2 Discrete Input (DI) Function Block, Proportional, Integral, and Derivative (PID) Function Block
- Function block instantiation, live download, auto commission/replacement
- Fast function block execution time: DI: 15ms, AI: 15ms, DO: 20ms, PID: 20ms
- Easy integration into AMS and DeltaV systems
- Device Dashboards powered by enhanced Electronic Device Description Language (EDDL)

### Position sensing/monitoring

- Optional GO switches for open/close status
- Optional potentiometer for position percentage indication, can be used for any rotation range between 20 and 320 degrees. End position offsets are adjustable.

### Control and monitor inputs and outputs

- Supports single/double and normal/reverse acting actuators
- Local LEDs for visual indication
- Local push buttons for calibration
- Remote configuration from control system or field communicator
- Stroke valve method
- Cycle count monitoring
- Open/close time monitoring
- Temperature monitoring
- Open/short circuit protection
- Integrated field diagnostics
- Embedded NAMUR NE 107 diagnostics

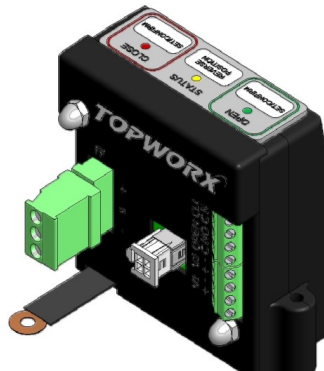

### Intrinsically Safe Input Parameters: Bus Connector pins 1 to 3

I.S. Parameters		FISCO Parameters	
Ui	30V	Ui	17.5V
li	380mA	li	380mA
Pi	1.5W	Pi	5.32W
Ci	5nF	Ci	5nF
Li	10μH	Li	10μH

### Electrical Specifications

Current Consumption	17.65mA nominal
Max. Applied Voltage	35VDC
Operating Voltage	9-32VDC

### Fieldbus Specifications

Topology	Point to Point Bus with Spurs Daisy Chain Tree
Cable	Twisted Pair
Bus Length	1900m (max)
Transmission Speed	31.25 kbit/s
Intrinsically Safe	Yes
Function Block Execution Times	DI 15ms AI 15ms DO 20ms PID 20ms

\*\*Pre-instantiated blocks are the pre-installed factory default function blocks. Instantiation is the capability to add blocks to and delete blocks from FF devices on the link. Up to 15 additional copies of each function block can be added to a device (except the transducer and resource blocks). Not an available feature in some DSC systems.

## D2-FF Assembly: "Inside the Box"

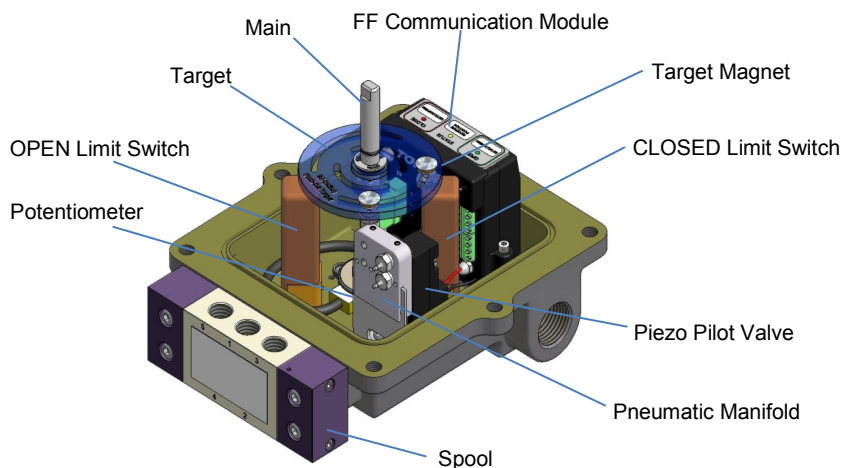

For more information concerning the TopWorx™ D2-FF Discrete Valve Controller visit us online at <http://www.topworx.com> and go to the download documents section or call 502-969-8000 and reference # ES-02512-1.

# AS-I Sensor Communication Module (SCM) : Option AS

## Option AS: SCM

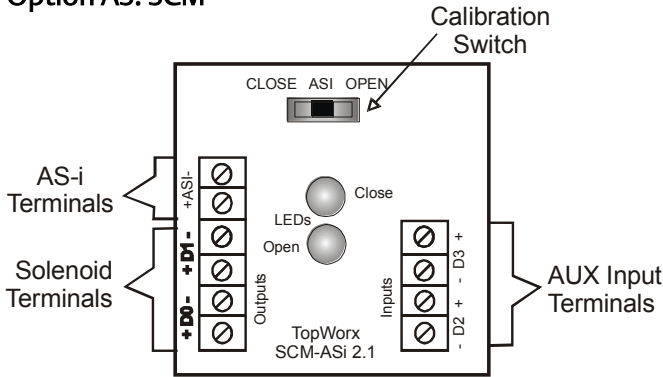

**Note:** Internal mount pilot in the DXP/DXS is 0.6W. For any externally mounted, or customer supplied, solenoid valve 4 watt maximum power consumption is allowed. A 170 mA max surge current limitation is required to prevent activation of the short circuit protection.

AS-i Specifications	
<b>Device ID</b>	A Free Profile
<b>Device I/O</b>	B 2 Inputs / 2 Outputs
<b>Inputs</b>	
<b>D2 Open Limit Switch</b>	0 Switch Open
<b>D3 Closed Limit Switch</b>	1 Switch Closed
<b>Outputs</b>	
<b>D1 Solenoid #1 (Close)</b>	0 De-energize Solenoid
<b>D0 Solenoid #2 (Open)</b>	1 Energize Solenoid
Output Power	
<b>Current &amp; Output Power</b>	40mA + open solenoid current and closed solenoid current Max solenoid current = 160mA per output Max power = 4 watts per output)
<b>Voltage</b>	20 to 30VDC

## Calibration

**Never** perform the switch calibration procedure where area is known to be hazardous.

### Step 1

Once pneumatic hookup and wiring has been completed close the valve using the SCM-ASi on-board calibration switch. If no AS-i network connection is available, you may connect a 24VDC power supply to the ASI terminals as previously described.

### Step 2

With the valve in the CLOSED position, disengage the BOTTOM cam from the splined hub and rotate Clockwise until the Red LED lights. Release the cam to re-engage the splined hub.

### Step 3

Open the valve by sliding the calibration switch to the OPEN position.

### Step 4

Once the valve is in the OPEN position, disengage the TOP cam from the splined hub and rotate Counter-clockwise until the Green LED lights. Release the cam to re-engage the splined hub.

### Step 5

Cycle the valve CLOSED and OPEN several times using the calibration switch to verify both limit switches are maintaining their set points.

### Step 6

Finally, slide the calibration switch to the ASI position. The AS-i network will now have full control of the valve once the SCM-ASi has been addressed.



**NOTE:** When upgrading a TopWorx™ AS-i module with a new TopWorx™ AS-i 2.1 module, make sure the input and output data bit positions are updated as indicated above.

## Wiring

### Step 1

For internally-mounted or external pilot device(s), wire the '+' and '-' leads to the terminals marked D0 (open) and D1 (closed). The internally-mounted pilot has an LED indicator for power verification.



**Note:** For an externally mounted solenoid valve, 4 watt maximum power consumption is allowed. A 160 mA surge current limit is required to prevent activation of the short circuit protection circuit.

### Step 2

Connect the AS-i communication wires to the terminals marked AS-i '+' and AS-i '-'.



**Note:** For calibration of the switches, a 24 VDC power supply may be used instead of an ASI Controller. If an ASI Controller is not available, wire +24 VDC to ASI+, and GND to ASI-. The calibration switch will still be able to actuate the valve.

### Additional Instruction for wiring an external switch input.

For externally mounted auxiliary input limit switches, wire switches to terminals marked -D2+ for open switch and -D3+ for closed limit switch.



**NOTE:** Refer to the wiring diagram on the inside lid of your product to determine actual pin out location.

# Reed Switch Sensor Communication Module (SCM) Calibration: Options R2/R4

## Option R2: SCM

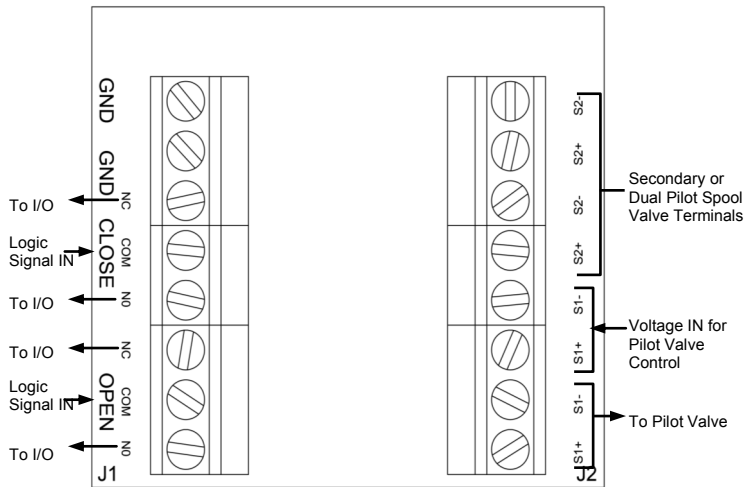

## Option R4: SCM

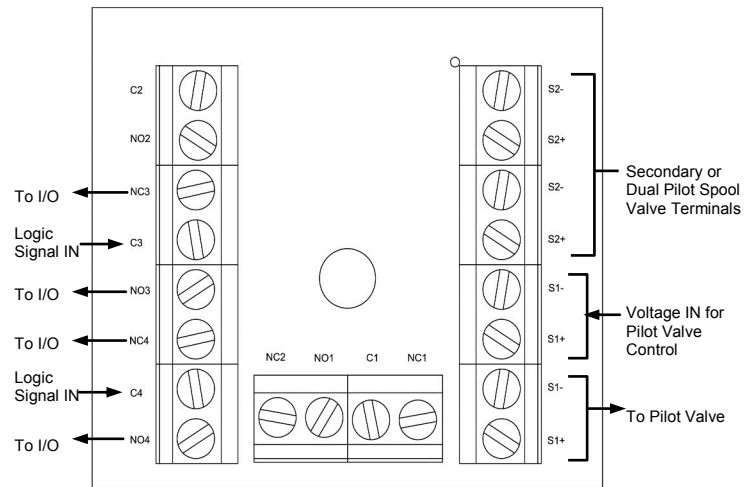

Electrical Ratings	
SCM R2/R4	200mA@120VAC (25W MAX)

**NOTE:** Refer to the wiring diagram on the inside lid of your product to determine wiring configuration and actual pin out location.  
**\*\*Install per control drawing #ES-01743-1**

## Calibration



**Never** perform limit switch calibration while an area is known to be hazardous.

First, be sure you have an air supply connected, and the appropriate spool valve to actuator connections. Set the air supply between 30 and 80psi.

### Step 1

For standard explosion-proof units: Using a 24VDC regulated power supply, connect (+) to COM and (-) to NO terminals. Limit current to the internal limit switches below maximum current ratings.



**Caution:** Many power supplies do not have current limiting; therefore, ALWAYS use a load resistor with a value of 200 to 2500 Ohms in series with the COM or NO legs of the circuit or damage may occur.

### Step 2

With the valve in the CLOSED position, disengage the lower cam from the splined Hub and rotate clockwise until the Red LED lights. Release the cam to re-engage the splined Hub, making sure it is seated on the splines. This sets the CLOSED limit switch.

### Step 3

Cycle the valve to the OPEN position using the attached control equipment.

### Step 4

While the valve is in the OPEN position, disengage the upper cam from the splined Hub and rotate the upper cam counter-clockwise until the Green LED lights. Release the cam to re-engage the splined Hub, making sure to seat the cam on the splines. This sets the OPEN limit switch.

### Step 5

Cycle valve several times to insure limit switches maintain calibration. Check that the target assembly is secure to the actuator pinion, and all air connections are tight.



**NOTE:** Continuity may be verified using a continuity light or by using an Ohmmeter in series with the NO connection.

## Continued Sensor Communication Module (SCM) Option PN/PS.

The TopWorx™ Sensor Communication Module (SCM) for the D-Series line, comprises integral conventional switch relays and LED driver circuits for ease of calibration, and local visual indication of the valve's state.

### SCM PS (Shown)

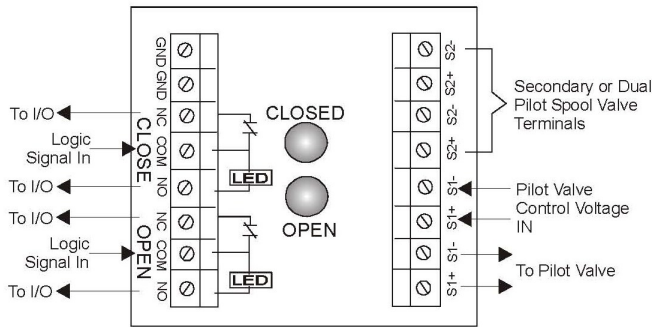

## Calibration of Limit Switches for SCM-PS

Never perform limit switch calibration while area is known to be hazardous.

First, be sure you have an air supply connected, and the appropriate spool valve to actuator connections, as illustrated in the Pneumatic Hookup section. Set the air supply between 30 and 80psi.

### Step 1

For Intrinsically Safe models, unit must be wired according to Control Drawing S-K087/087A to prevent possible damage to I.S. components, or for standard explosion-proof units: Using a 24VDC regulated power supply, connect (+) to COM and (-) to NO terminals. Maximum current rating for units with LEDs is 0.25A.

**Caution:** Many power supplies do not have clipping circuits to dampen surge currents; therefore, ALWAYS use a load resistor with a value of 200 to 2500 Ohms in series with the COM or NO legs of the circuit or damage may occur.

A 9V battery may be used as an alternate power source. No load resistors are required.

### Step 2

With the valve in the CLOSED position, disengage the lower Cam from the splined Hub and rotate clockwise until the Red LED light illuminates. Release the Cam to re-engage the splined Hub, making sure it is seated on the splines. This sets the CLOSED limit switch.

### Step 3

Cycle the valve to the OPEN position using the attached control equipment.

### Step 4

While the valve is in the OPEN position, Disengage the upper Cam from the splined Hub and rotate the upper Cam counter-clockwise until the Green LED illuminates. Release the Cam to re-engage the splined Hub, making sure to seat the Cam on the splines. This sets the OPEN limit switch.

### Step 5

Cycle valve several times to insure the limit switches maintain calibration. Check that the target assembly is secure to the actuator pinion, and all air connections are tight.

**When using the SCM-PN module without LEDs, continuity may be verified using a continuity light or by using an Ohmmeter in series with NO connection.**

## Conventional SCM-PS & SCM-PN Electrical Ratings

Electrical Ratings		
	Current	Voltage
<b>SCM PS w/LED'S</b>	0.25A@24VDC 0.20A@120VAC	5V
<b>SCM PN w/o LED'S</b>	1.0A@24VDC 0.20A@120VAC	0V

## ESD Theory of Operation

The purpose of the TopWorx™ Emergency Shut-Down (ESD) model is to partially stroke a valve that maintains a full open or full closed position for an extended period of time while offering an ESD function. A partial stroke test (PST) verifies functionality of critical valves that must be in their fail position during an emergency. Increasing the frequency of partial stroke testing (i.e. reducing the proof test interval) improves the SIL (Safety Integrity Level) that the system can achieve through a reduction in the PFD avg (Average Probability of Failure On Demand). These partial stroke tests can be performed without shutting down or disrupting the process. In an emergency, the ESD function overrides partial stroke testing and the valve moves to its fail position.

This ESD unit incorporates a sensor communication module (SCM-ESD) to perform the partial stroke test, verify its status, and output that status back to the user. In combination with the SCM, the ESD unit uses either the optional TopWorx™ pilot and spool valve or a customer-supplied solenoid valve to drive the actuator during both normal operation and partial stroke testing. A TopWorx™ GO™ Switch is included for partial stroke confirmation and two (2) limit switches built into the SCM confirm open and close position.

Once the unit is installed, the SCM-ESD must be calibrated for that specific valve, actuator, and solenoid exhaust settings. During calibration, the unit records the time to partially stroke the valve. All future PST times are compared to this original value for determining the test status. To pass a PST, the time must be within +/-20%, 30%, or 40% of the stored calibration value. This PST time tolerance can be changed prior to calibration.

The partial stroke test is initiated via an optional partial stroke test button with a lockable cover, the calibration button on the top of the SCM, or a pulsed DO from the PLC. Upon issuing a PST command, the SMC-ESD begins a timer while switching a relay to de-energize the pilot/ solenoid. The valve moves from its normal position toward its fail position until the GO™ Switch is made. Once made, the SCM energizes the pilot/solenoid and the valve moves to its normal position while outputting the PST status.

## Option ES: SCM

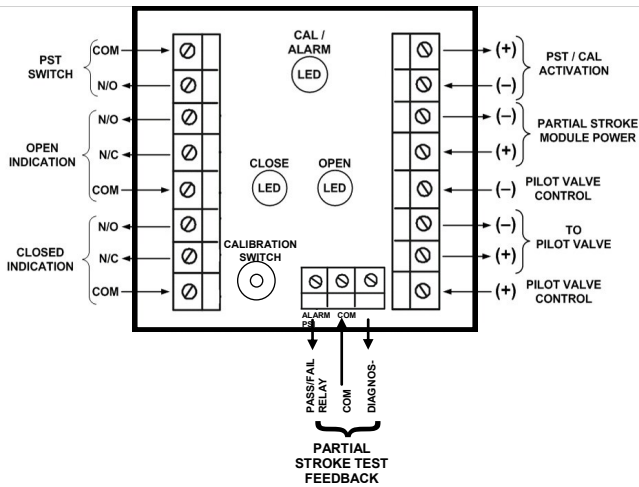

Electrical Ratings	
	Current/Voltage
Open/Closed Indication	0.25A@24VDC w/5V drop 0.25A@120VAC w/5V drop
Module Voltage	18-28VDC
Module Current	50mA (MAX)
Pilot Current (Standard)	20mA
PST Feedback Relays	800mA@24VDC MAX 250mA@125VAC MAX
Pilot MAX Valve Rating	800mA@24VDC MAX 250mA@125VAC MAX

## Suggested Calibration Set-Up:

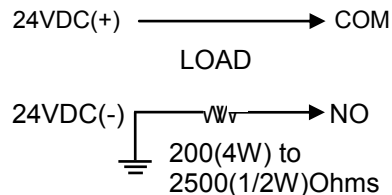

## For More Information

To download more information concerning the TopWorx™ D-Series ESD Valve Controller, including a copy of the **Sira Functional Safety Assessment Report** visit us online at

<http://www.topworx.com>

or call 502-969-8000 and reference # ES-00936-1.





## Appendix B Proof Tests to Reveal Dangerous Undetected Faults

According to section 7.4.5.2 f) of IEC 61508-2 proof tests shall be undertaken to reveal dangerous faults which are undetected by automatic diagnostic tests. This means that it is necessary to specify how dangerous undetected faults which have been noted during the Failure Modes, Effects, and Diagnostic Analysis can be detected during proof testing.

### B.1 Suggested Proof Test

The suggested Proof Test consists of a full stroke of the Actuator and Valve. Refer to the table in B.2 for the Proof Test Coverage.

The suggested Proof Test consists of a full stroke of the Valve Controller and Valve, see Table 7.

**Table 7 Suggested Proof Test – Valve Controller**

Step	Action
1.	Bypass the safety function and take appropriate action to avoid a false trip.
2.	Check for excessive air supply consumption.
3.	Initiate a partial valve stroke test using the Topworx D-ESD Valve Controller and verify that the attached Valve fully moves to the partial stroke position within the correct time.
4.	Inspect for any leaks, visible damage or contamination and confirm that the normal operating state was achieved.
5.	Remove the bypass and otherwise restore normal operation.

For the test to be effective the movement of the Valve must be confirmed. To confirm the effectiveness of the test both the travel of the Valve and slew rate must be monitored and compared to expected results to validate the testing.

### B.2 Proof Test Results

The dangerous undetected failures ( $DU_{PT}$ ) remaining after proof testing with and without PVST are given in Table 8. The Topworx D-ESD Valve Controller is only one device in the final element. The listed failure rates must be added to the  $DU_{PT}$  for the other devices in the final element to determine the proof test coverage for the element. To perform the PFDavg calculation the proof test coverage must be determined for the entire final element.

**Table 8 Proof Test Results – Topworx D-ESD Valve Controller**

Device	Dangerous Undetected Failures After Proof Testing (FIT)
Single Acting Actuator Application w/out PVST	11
Single Acting Actuator Application w/PVST	11

## DeviceNet Sensor Communication Module (SCM): Option DN

### Basic DeviceNet I/O Operation

The DeviceNet Sensor-Communications Module (known hereafter as SCM-DN) operates as a combined discrete input and output device on the DeviceNet network. It is a slave (server) device that can be allocated by the system implementer to one specific master (client). There are several parameters that may be modified by the user. These are collected in a block of data called the Parameter Object (See Table, 11-1A). They may be left as defaulted, depending upon your application.

The Polled I/O feature follows the conventional method of a client requesting data from and/or sending data to one server at a time. This requires both a command message from the client and a response message from each server for every set of I/O. To improve throughput on the network Change-of-State and Cyclic I/O functions have been defined by the DeviceNet protocol. These functions are supported by the SCM-DN. The discrete data returned in the poll response to the client will contain both valve contact input and valve command output status data.

### Polled I/O

The client can poll (read) the input and command the output status from the SCM-DN and can energize or de-energize the discrete outputs on the SCM-DN. The status LEDs report the actual state of the valve; i.e. the red led is lit when the valve is closed, and the green led is lit when the valve is open.

The client controls the valve outputs by sending a poll command to the SCM-DN. If no data is sent to the SCM-DN during a poll, then the outputs are put into the "idle" state and their actions are then governed by the Idle Action and Idle Value attributes of the Parameter Object (See Table, 11-1A).

Both idle and fault operations are implemented for the valve output points. The outputs can be set individually to hold last state or to implement user-defined states upon receipt of an "idle" command or upon a "fault" condition. You can implement these actions via the Parameter Object (See Table, 11-1A).

### Cyclic and Change-of-State I/O

Both the Cyclic and Change-Of-State (COS) are activated by allocating a connection for one or the other using the allocate service of the DeviceNet Object (class 3), and setting the EPR (Expected Packet Rate) for that connection. The value for the EPR is used to set the various communication timers.

The Cyclic connection initiates a transmission every time the connection timer expires. The cyclic connection can only send data from the SCM-DN to its assigned client. The polled and cyclic connections are not exclusive, so both can exist at the same time. The manner in which cyclic connection reports its data is the same as the polled connection.

The Change of State (COS) connection is the same as the cyclic connection except that as well as triggering communications on the expiration of the timer, the COS connection also initiates a

transfer on a change of the valve's status. The COS connection is mutually exclusive with the cyclic connection, but can coexist with the polled connection. The COS connection operation is very useful in conserving bandwidth, and provides the client with the most current data as fast or faster than a poll connection. The COS connection automatically turns on the COS mechanism when the connection is created.

## Quick Start for DeviceNet

### Limit Switch Calibration

**Never** perform switch calibration while area is known to be hazardous.

**Step 1:** Once pneumatic hookup and wiring has been completed close the valve using the SCM-DN on-board calibration switch. If no DeviceNet network connection is available, you may connect to a 24VDC power supply.

**Step 2:** Place the calibration switch in the closed position. With the valve in the CLOSED position, disengage the bottom cam from the splined Hub and rotate Clockwise until the Red LED lights. Release the cam to re-engage the splined Hub. Be sure the cam is seated on the Hub.

**Step 3:** Open the valve by sliding the calibration switch to the OPEN position.

**Step 4:** While the valve is in the OPEN position, disengage the top cam from the splined Hub and rotate Counterclockwise until the Green LED lights. Release the cam to re-engage the splined Hub. Be sure the cam is seated on the Hub.

**Step 5:** Cycle the valve CLOSED and OPEN a few times using the calibration switch to verify both limit switches are maintaining their set points.

**Step 6:** Finally, slide the calibration switch to the DeviceNet position. The DeviceNet network will now have full control of the valve once the SCM-DN has been addressed.

### How to Install and Establish DeviceNet Communications

**Step 1:** Connect the DeviceNet cable to the round 5-pin round mini or micro connector according to DeviceNet cable wiring specifications, or wire directly to the terminals on the SCM-DN.

**Step 2:** Make sure that the DeviceNet network is terminated properly.

**Step 3:** Set the baud rate and address of the SCM-DN if different from default (See Baud Rate Selection 11-1D).

**Step 4:** Make sure that there is power on the DeviceNet network and that it is plugged into a Master device.

**Step 5:** Wire the DeviceNet cable to the SCM-DN.



## Continued How to Install and Establish DeviceNet Communications Continued

**Step 6:** In fixed baud rate mode, the SCM-DN will undergo its initialization sequence, flashing both LEDs. After approximately 4 seconds, the Module Status LED (labeled “MS”) will go on solid green and the Network LED will flash green.

**Step 7:** In autobaud mode, the SCM-DN the Module Status LED will continue to blink until the SCM-DN recognizes valid traffic on the DeviceNet link and syncs to a specific baud rate.

**Step 8:** The green Network Status LED (labeled “NS”) will go on solid once the Master recognizes the unit on the link and allocates the connection (commissions it).

**Step 9:** The SCM-DN is now operating on the network.

**Configuration Parameters (Class 15) Table 11-1A**

Instance	Parameter Name	Values	Default Setting	Default Value	Description
1	Max Open Time	0 to 65535	Disabled	0	Max time allowed for valve to Open before triggering an alarm
2	Max Close Time	0 to 65535	Disabled	0	Max time allowed for valve to Close before triggering an alarm
3	Cycle Count Limit	0 to 4294967295	Disabled	0	Max number of cycles allowed before triggering an alarm
4	Analog High Limit	0 to 255	Disabled	255	Highest analog value before triggering an alarm
5	Analog Low Limit	0 to 255	Disabled	0	Lowest analog value before triggering an alarm
6	DNet Fault Action	0 or 1	Use Fault Value	0	0 = Use fault value 1 = Hold last state
7	DNet Fault Value	0 thru 3	OFF	0	0 = OFF 1 = Open 2 = Close 3 = No change
8	DNet Idle Action	0 or 1	Use Fault Value	0	0 = Use fault value 1 = Hold last state
9	DNet Idle Value	0 thru 3	OFF	0	0 = OFF 1 = Open 2 = Close 3 = No change
10	Assembly Config	1 to 4	Standard Assembly	1	1 = Status & Alarm bytes 2 = Status & Alarm bytes + last Open & Close Times 3 = Status & Alarm bytes + Cycle Count 4 = Status & Alarm bytes + last Open/Close Times + Cycle Count

## Continued How to Configure the DeviceNet Node Address and Baud Rate

**Step 1:** The address and baud rate can be set using the 6-position DIP switch blocks, SW1 and SW2 (as seen on Fig. 11-1A).

**Step 2:** Switches 1 and 2 on SW2 define the baud rate selection as shown in the Baud Rate Selection Table, 11-1D.

**Step 3:** Switches 1 through 6 on SW1 define the address selection as shown in the Address Selection Table, 11-1B.

**Step 4:** Switch setting changes will NOT take effect until the device is reset with either a RESET command or a power cycle.

### How to Configure the Network Communications Protocol

**Step 1:** Switches 3, 4 and 5 on SW2 define which link is selected –DeviceNet or Modbus – as shown in the Communications Protocol Selection Table, 11-1C.

**Step 2:** For DeviceNet set all 3 switches OFF or 0N.

**Step 3:** If you change the switches, the new selection will not become effective until the unit is power cycled or a Reset command is received by the SCM-DN.

**Step 4:** Switch 6 of SW2 selects the Modbus protocol for ASCII or RTU as shown in the Modbus Protocol Table, 11-1E.

## DeviceNet Sensor Communication Module (SCM): Option DN 11-1A

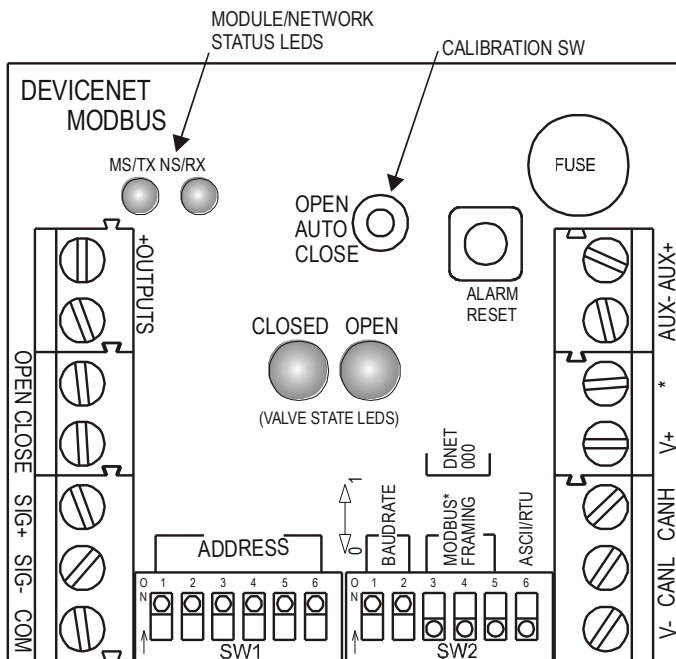

### SCM-DN

The network shield is not terminated. Connections to the pilot valve and relay contacts are all made internal to the enclosure.

Continued

Address Selection 11-1B

ADDRESS Switch Position						
Node Address	SW 1,1	SW 1,2	SW 1,3	SW 1,4	SW 1,5	SW 1,6
	Switch Position Values					
	32	16	8	4	2	1
0	OFF	OFF	OFF	OFF	OFF	OFF
1	OFF	OFF	OFF	OFF	OFF	ON
2	OFF	OFF	OFF	OFF	ON	OFF
3	OFF	OFF	OFF	OFF	ON	ON
4	OFF	OFF	OFF	ON	OFF	OFF
5	OFF	OFF	OFF	ON	OFF	ON
...						
62	ON	ON	ON	ON	ON	OFF
63	ON	ON	ON	ON	ON	ON

Baud Rate Selection 11-1D

DeviceNet Baud Rate	DIP Switch Position	
	SW 2,1	SW 2,2
125k	OFF	OFF
250k	OFF	ON
500k	ON	OFF
Autobaud	ON	ON

Communications Protocol Selection 11-1C

DeviceNet	Modbus	DIP Switch Position		
		SW 2,3	SW 2,4	SW 2,5
DeviceNet	N/A	OFF	OFF	OFF
N/A	7,N,2	OFF	OFF	ON
N/A	7,E,1	OFF	ON	OFF
N/A	7,O,1	OFF	ON	ON
N/A	8,N,1	ON	OFF	OFF
N/A	8,N,2	ON	OFF	ON
N/A	8,E,1	ON	ON	OFF
N/A	8,O,1	ON	ON	ON

Modbus Protocol 11-1E

Modbus Protocol	DIP Sw Position
	SW 2,6
ASCII	OFF
RTU	ON

## Pneumatic Hookup Procedures

Prior to connecting the supply air to the spool valve, flush the system to remove any debris or contaminants. Galvanized pipe can easily flake and contaminate the system and therefore is not recommended. A 40 micron point of use filter at every device is recommended.

## 4-Way Spool Valves

The TopWorx™ spool valve is a 5 port, 4-way valve driven by an internally mounted pilot. The spool valve supply port and work ports are marked as follows:

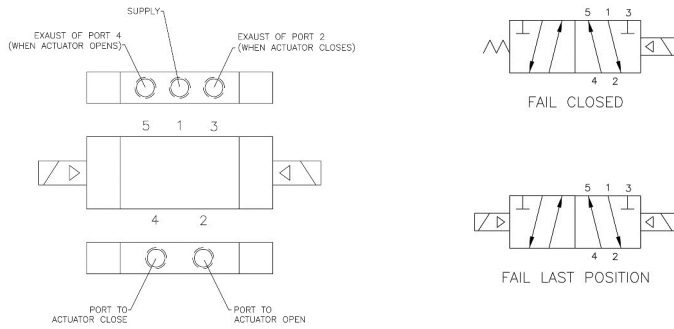

**\*\*\*Never Plug, Block or Restrict Port 5\*\*\***

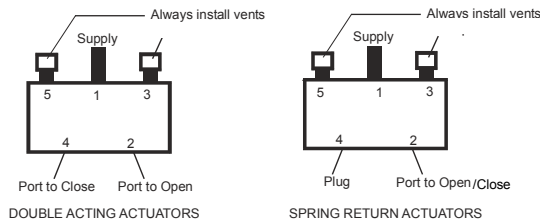

Spool Valve Specifications	
Medium	Dried, filtered air (40 micron)
Max Operating Pressure	100psi (0.69 MPa) (6.89Bar)
Min. Operating Pressure	30psi (0.21 MPa) (2.07Bar)
Max Consumption Rate	600 cc/min @ 80psi
Ambient Temperature Range	Refer to Product Nameplate Marking
Flow Coefficient	1.2Cv or 3.0Cv
Environment Rating	Type 4, 4X, IP67
Port Size	1/2" NPT for 3.0Cv valve 1/4" NPT for 1.2Cv valve
Manual Override	Available in Latching/Non-Latching Push Type & Palm Actuator Type
Valve Body	Available in Hardcoat Anodized Aluminum, 304, or 316 Stainless Steel
Valve Seals	Spool Seals: Buna-N Valve Body Seals available in Buna & Silicone

### Don't forget!

TopWorx™ has a complete line of breathers, flow controls, regulators and filters.

Check out [www.topworx.com](http://www.topworx.com) or call us at 502.969.8000 for more details

### DID YOU KNOW?

TopWorx™ manufactures the globally-known GO™ Switch Leverless Limit Switch, which comprises a full line of harsh environment sensors. If your application is very cold, very hot, under water or in a caustic atmosphere, then GO™ Switch has the answer.

## Highly Recommended

TopWorx™ highly recommends Loctite 567 brand thread sealant. Do not use a hard setting pipe compound. If Teflon thread seal tape is used, start the wrap on the second thread from the leading thread of the fitting. This will prevent tape shreds from contaminating the spool valve seals.

Breathers (AL-M31) should be installed in the exhaust ports to keep debris from falling into the spool valve and damaging the seals. This must be addressed prior to installation, or storage.

A flow control may be used in Port 3, but should NEVER BE USED in Port 5. Any blockage or restriction may cause an internal pressure build-up inside the enclosure and pose a safety issue.

## Spool Valve Assembly

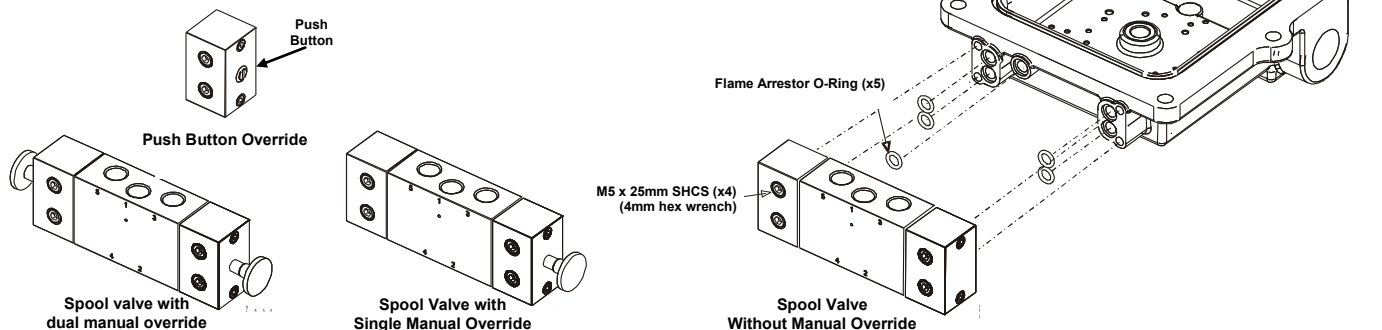

# Continued Spool Valves and Pilots

## Pilot Device Assembly

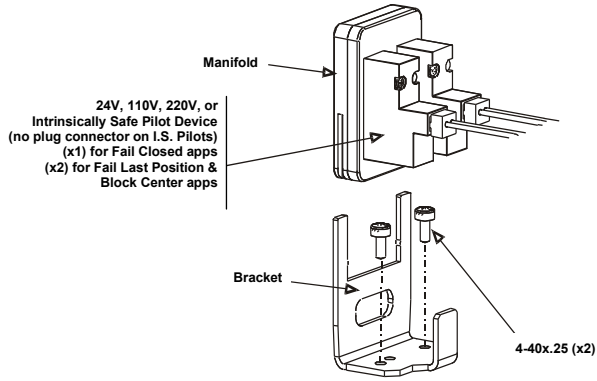

### SINGLE I.S. PILOT ASSEMBLY

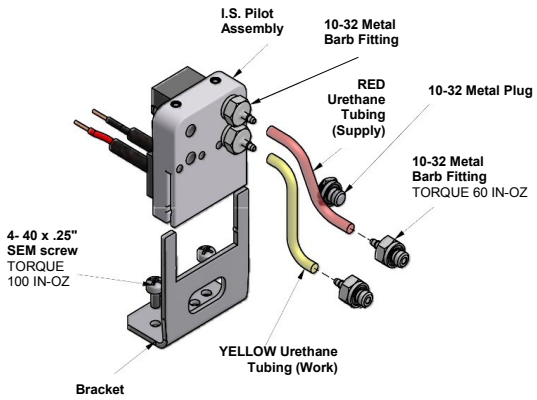

### DUAL I.S. PILOT ASSEMBLY

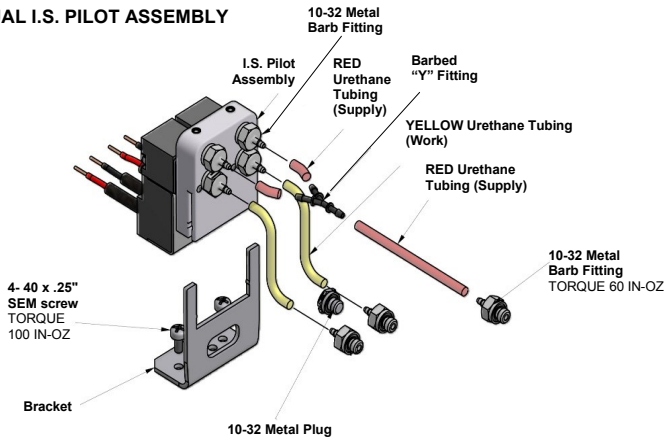

### SINGLE PILOT ASSEMBLY

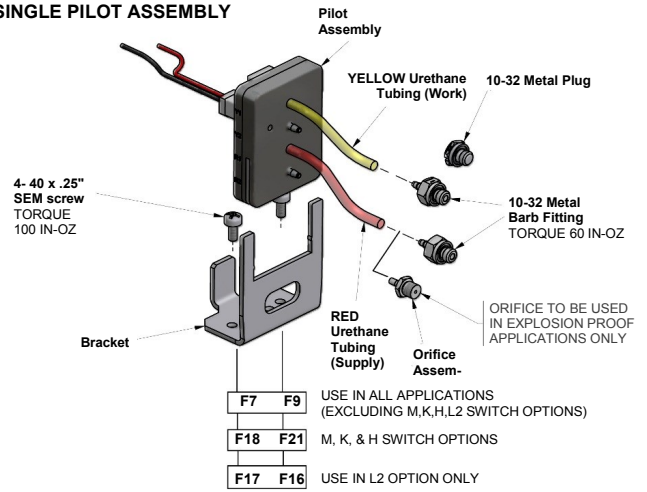

### DUAL PILOT ASSEMBLY

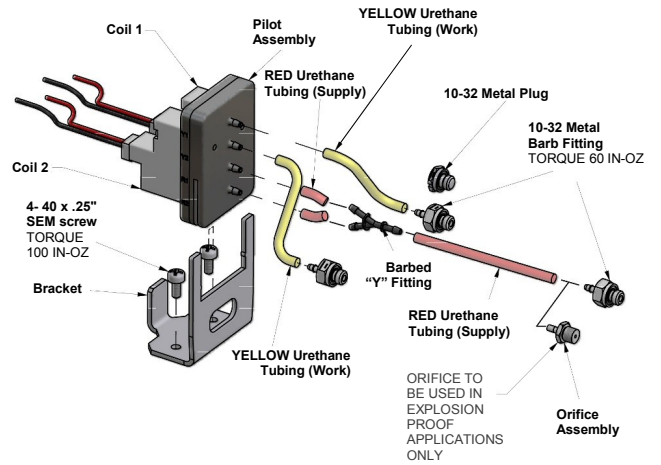

## Proof Testing for D-Series TopWorx™

### D-Series Safety Functions

The safety functions of the D-Series Discrete Valve Controller are defined as:

- To relieve pneumatic pressure to the spool valve by de-energizing the solenoid valve allowing the actuator to perform its safety function.
- To admit pneumatic pressure to the spool valve by energizing the solenoid valve allowing the actuator to perform its safety function.

The actuator and valve may be configured to fail safe in a normally open (N/O) or normally closed (N/C) configuring depending on the process under control. The D-Series controller requires an air supply in some form which must be assessed by the end user to ensure the required SIL is achieved. E.g. If the D-Series controller is configured with the safety function to relieve pneumatic pressure to the actuator in order for it to revert to its fail safe state then a failure of the air supply will be a safe failure.

The D-Series Discrete Valve Controller could benefit from an increase in availability by incorporating the GO magnetic proximity switches at the Partial Valve Stroke Test (PVST) position and utilize a PVST command into the PLC which will perform a PVST either automatically or by an operator at no longer than the prescribed intervals with the operator taking the appropriate action in the event of a failure being detected by PVST.

### Hardware Functional Description

The D-Series Discrete Valve Controller implements the safety functions as a sub-system as defined according to IEC 61508-2 clause 7.4.2.11 Note 1. Furthermore, with reference to IEC 61508-2 clause 7.4.4.1.2/3, the full assembly can be classified as a "Type A" sub-system.

#### No fault (normal) conditions

- a) Under normal operating conditions the D-Series Discrete Valve Controller will maintain the Normally Open (N/O) actuator / valve in the closed position or the Normally Closed (N/C) actuator / valve in the open position.
- b) The bus networking device may relay valve positional data to the operator during normal operating conditions but this device is not responsible for implementing the safety function.

#### Self diagnosed fault conditions

The D-Series Discrete Valve Controller does not have any online fault diagnostics however if the D-Series Discrete Valve Controller develops a fault which reverts the valve to its fail safe state then the sensor module will know this change in valve position through the integrated shaft which is coupled to the valve. The bus networking device can then notify the operator of a valve position change without being requested. This kind of failure is a safe detectable failure ( $\lambda_{SD}$ ) and is considered as such in the FMEDA.

If the D-Series Discrete Valve Controller develops a fault which latches the valve in its current, potentially dangerous, state then this form of failure will only be acknowledged during proof test, PVST or when a demand is placed on the element. The bus networking device can only notify the operator of no valve movement after the failure event has occurred and therefore this kind of failure is a dangerous undetectable failure ( $\lambda_{DD}$ ) and is considered as such in the FMEDA.

The utilization of PVST by the D-Series Discrete Valve Controller will reveal any covert undetected dangerous failures and therefore increase the availability of the device. The use of PVST as a diagnostic tool will enable the following actions:

- Detect the valve position.
- Detect valve movement.
- Measure the time to travel from open to partial stroke position.

It should be realized that the electronics in the D-Series Discrete Valve Controller are performing positional feedback to the PLC and operator which is not considered online diagnostics. Diagnostics coverage is assessed in the FMEDA according to utilizing PVST to reveal covert undetected dangerous failures. This Diagnostic coverage is only applicable at the point of PVST and not for normal operations.

### For More Information

To download more information concerning the TopWorx™ D-Series Valve Controller, including a copy of the Sira Functional Safety Assessment Report visit us online at

<http://www.topworx.com>

Or call 502-969-8000



Continued

### Proof Testing for D-Series TopWorx™

Sira Test & Certification Ltd has conducted a Failure Mode, Effect and Diagnostic Analysis (FMEDA) of the D-Series Discrete Valve Controller against the requirements of IEC61508-2.

#### Report Summary

D-Series Discrete Valve Controller			
Safety Function: "TO CLOSE OFF (RELIEVE) PNEUMATIC PRESSURE TO THE SPOOL VALVE"			
Architectural constraints:	Type A HFT=0 SFF 87.39%	Proof Test Interval =8760Hrs <sup>(4)</sup> MTTR = 8 Hrs <sup>(4)</sup>	SIL2
Random hardware failures:	$\lambda_{DD} = 0$ $\lambda_{DU} = 2.90E-08$	$\lambda_{SD} = 0$ $\lambda_{SU} = 8.40E-08$	
Probability of failure on demand:	$PFD_{avg} = 1.27E-04$ (Low Demand Mode)		SIL3
Average Frequency of Dangerous failure on safety function:	$PFH = 2.90E-08$ (High Demand Mode)		SIL3
Hardware safety integrity compliance	Route 1 <sub>H</sub>		
Systematic safety integrity compliance	Route 1 <sub>S</sub>		
Systematic Capability	SC 3 (See report R56A24114B)		
Overall SIL-capability achieved	SIL 2 (Low Demand) SIL 2 (High Demand)		

D-Series Valvetop Indicator using simple switches			
Safety Function: "TO PROVIDE AN INDICATION OF THE MONITORED VALVE POSITION"			
Architectural constraints:	Type A HFT=0 SFF=89%	Proof Test Interval =8760Hrs <sup>(4)</sup> MTTR = 8 Hrs <sup>(4)</sup>	SIL2
Random hardware failures:	$\lambda_{DD} = 6.74E-08$ $\lambda_{DU} = 7.50E-09$	$\lambda_{SD} = 0.00E-00$ $\lambda_{SU} = 0.00E-00$	
Probability of failure on demand:	$PFD_{avg} = 3.34E-05$ (Low Demand Mode)		SIL4
Average Frequency of Dangerous failure on safety function:	$PFH = 7.50E-09$ (High Demand Mode)		SIL4
Hardware safety integrity compliance <sup>(1)</sup>	Route 1 <sub>H</sub>		
Systematic safety integrity compliance <sup>(1)</sup>	Route 1 <sub>S</sub>		
Systematic Capability <sup>(2)</sup>	SC 3 (See report R56A24114B)		
Overall SIL-capability achieved <sup>(3)</sup>	SIL 2 (Low Demand) SIL 2 (High Demand)		

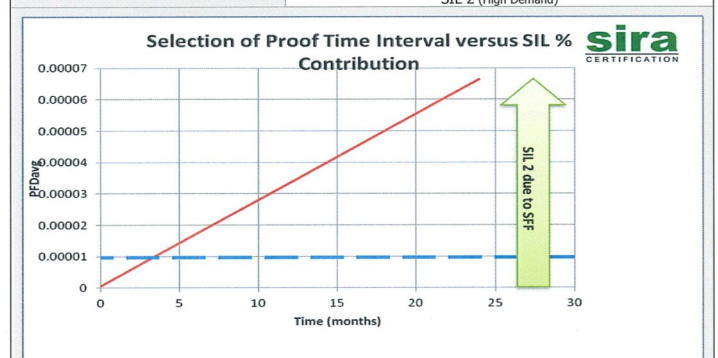
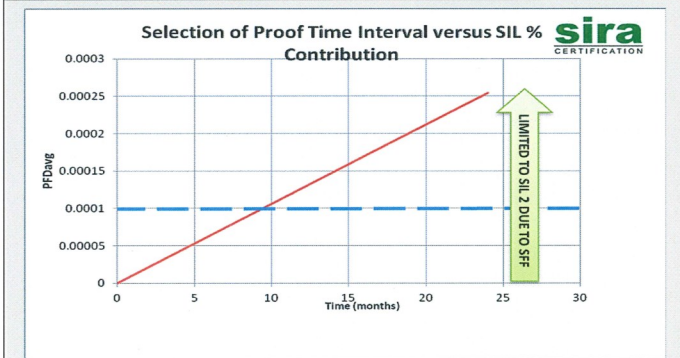

- (1) These are new parameters used in IEC61508 Part 2 Sections 7.4.2 & 7.4.4
- (2) This is a new measurable scale for the systematic safety integrity level; refer to IEC61508 Part 4 Section 3.5.9
- (3) This is determined by the lowest SIL indicated by each of the parameters given above.
- (4) These figures are used only for demonstration purposes only.

D-Series Valvetop Indicator using simple switches			
Safety Function: "TO PROVIDE AN INDICATION OF THE MONITORED VALVE POSITION"			
Architectural constraints:	Type A HFT=0 SFF=89%	Proof Test Interval =8760Hrs <sup>(4)</sup> MTTR = 8 Hrs <sup>(4)</sup>	SIL2
Random hardware failures:	$\lambda_{DD} = 6.74E-08$ $\lambda_{DU} = 7.50E-09$	$\lambda_{SD} = 0.00E-00$ $\lambda_{SU} = 0.00E-00$	
Probability of failure on demand:	$PFD_{avg} = 3.34E-05$ (Low Demand Mode)		SIL4
Average Frequency of Dangerous failure on safety function:	$PFH = 7.50E-09$ (High Demand Mode)		SIL4
Hardware safety integrity compliance <sup>(1)</sup>	Route 1 <sub>H</sub>		
Systematic safety integrity compliance <sup>(1)</sup>	Route 1 <sub>S</sub>		
Systematic Capability <sup>(2)</sup>	SC 3 (See report R56A24114B)		
Overall SIL-capability achieved <sup>(3)</sup>	SIL 2 (Low Demand) SIL 2 (High Demand)		

D-Series Valvetop Indicator using GO switches (Z series, L series and 35 series)			
Safety Function: "TO PROVIDE AN INDICATION OF THE MONITORED VALVE POSITION"			
Architectural constraints:	Type A HFT=0 SFF=91%	Proof Test Interval =8760Hrs <sup>(4)</sup> MTTR = 8 Hrs <sup>(4)</sup>	SIL3
Random hardware failures:	$\lambda_{DD} = 7.07E-08$ $\lambda_{DU} = 7.50E-09$	$\lambda_{SD} = 0.00E-00$ $\lambda_{SU} = 0.00E-00$	
Probability of failure on demand:	$PFD_{avg} = 3.35E-05$ (Low Demand Mode)		SIL4
Average Frequency of Dangerous failure on safety function:	$PFH = 7.50E-09$ (High Demand Mode)		SIL4
Hardware safety integrity compliance <sup>(1)</sup>	Route 1 <sub>H</sub>		
Systematic safety integrity compliance <sup>(1)</sup>	Route 1 <sub>S</sub>		
Systematic Capability <sup>(2)</sup>	SC 3 (See report R56A24114B)		
Overall SIL-capability achieved <sup>(3)</sup>	SIL 3 (Low Demand) SIL 3 (High Demand)		

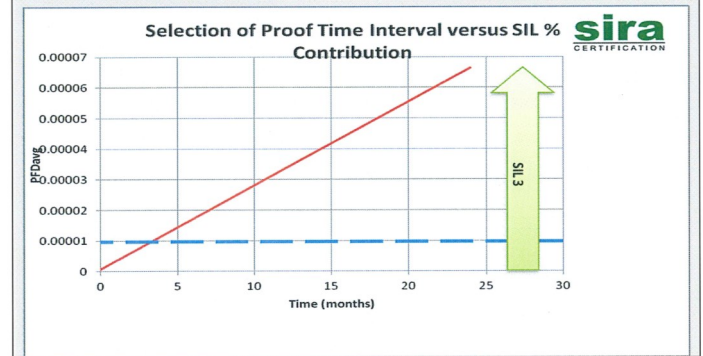
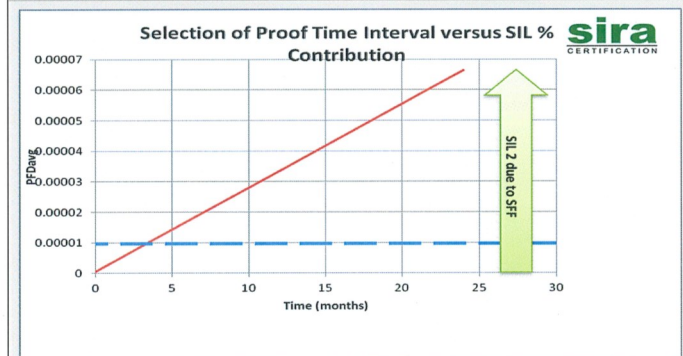



# Dimensions and Materials: TopWorx™ DXP

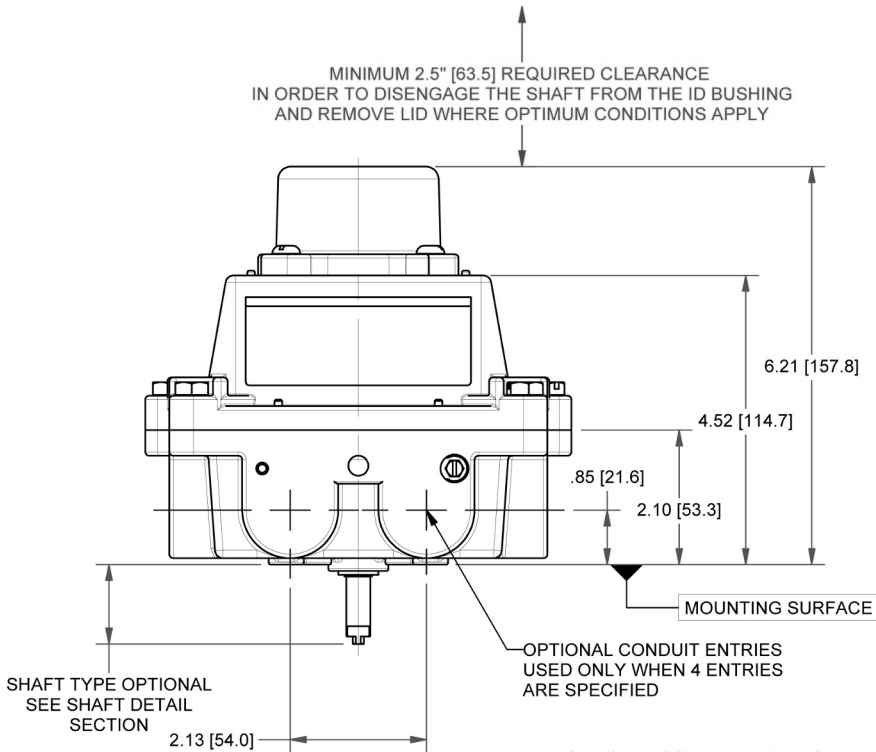

MATERIALS OF CONSTRUCTION	
Enclosure	Cast A360 aluminum with dichromate conversion coating inside & out, epoxy coated exterior rated for 250 hrs. salt spray per ASTM B117
Fasteners	304 Stainless Steel standard 316 Stainless Steel optional
Shaft	304 Stainless Steel standard 316 Stainless Steel optional
Shaft Bushing	Oilite Bronze
Indicator Dome	Polycarbonate, UV F1 rated
Seals	O-ring seals available in: Buna, & Silicone

Fastener Torque Specifications	
Enclosure Housing Bolts	8 ft.-lbs [10.8 N·m] +/-10%
Indicator Dome Screws	320 in.-oz. [2.3 N·m] +/-10%
Bottom Mounting Holes	10 ft.-lbs [13.6 N·m] +/-10%

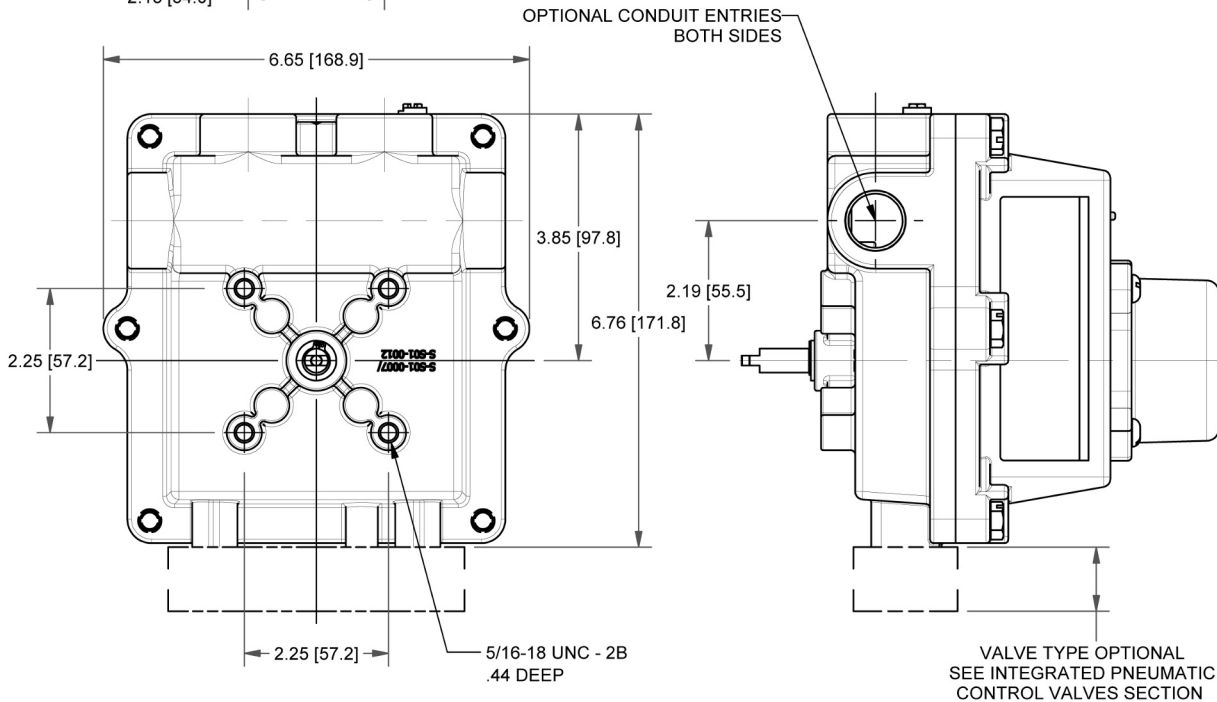

# Dimensions and Materials: TopWorx™ DXP - Flameproof Ex d IIC

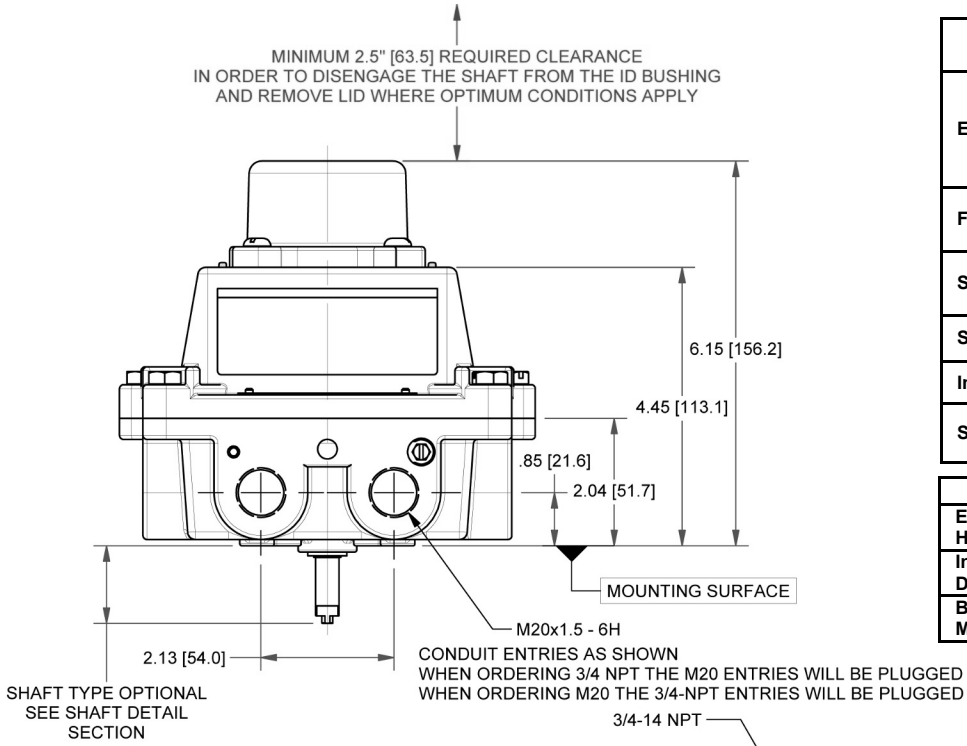

MATERIALS OF CONSTRUCTION	
Enclosure	Cast A360 aluminum with dichromate conversion coating inside & out, epoxy coated exterior rated for 250 hrs. salt spray per ASTM B117
Fasteners	304 Stainless Steel standard 316 Stainless Steel optional
Shaft	304 Stainless Steel standard 316 Stainless Steel optional
Shaft Bushing	Oilite Bronze
Indicator Dome	Polycarbonate, UV F1 rated
Seals	O-ring seals available in: Buna, & Silicone

Fastener Torque Specifications	
Enclosure Housing Bolts	8 ft.-lbs [10.8 N·m] +/-10%
Indicator Dome Screws	320 in.-oz [2.3 N·m] +/-10%
Bottom Mounting Holes	10 ft.-lbs [13.6 N·m] +/-10%

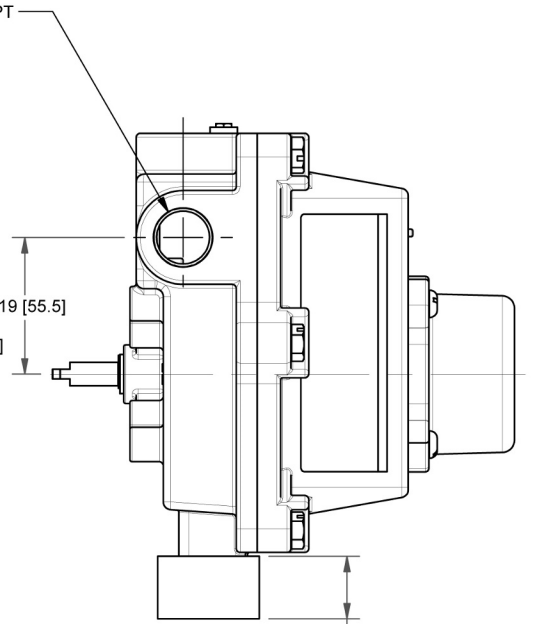
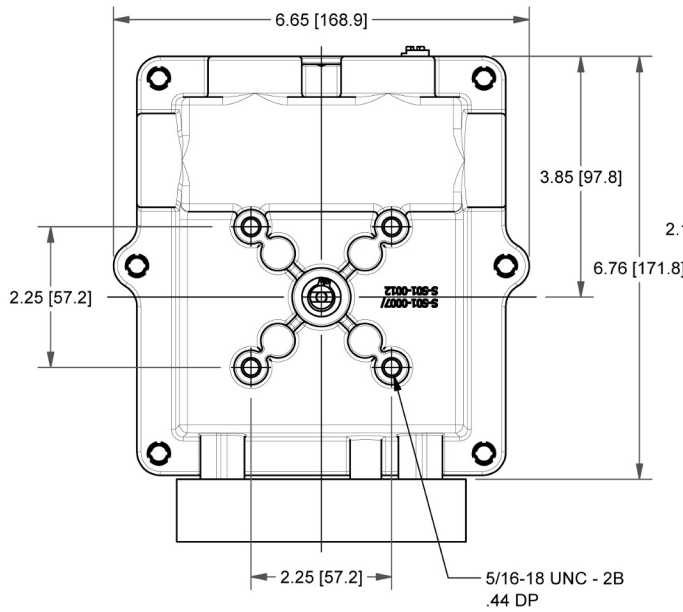

OPTIONAL SEE INTEGRATED PNEUMATIC CONTROL VALVE SECTION  
ALL UNITS ARE DESIGNED FOR VALVE INTEGRATION WHEN NO VALVE IS SPECIFIED  
ALLOW 1/2" FOR BLANKING PLATE CLEARANCE

# Dimensions and Materials: TopWorx™ DXS

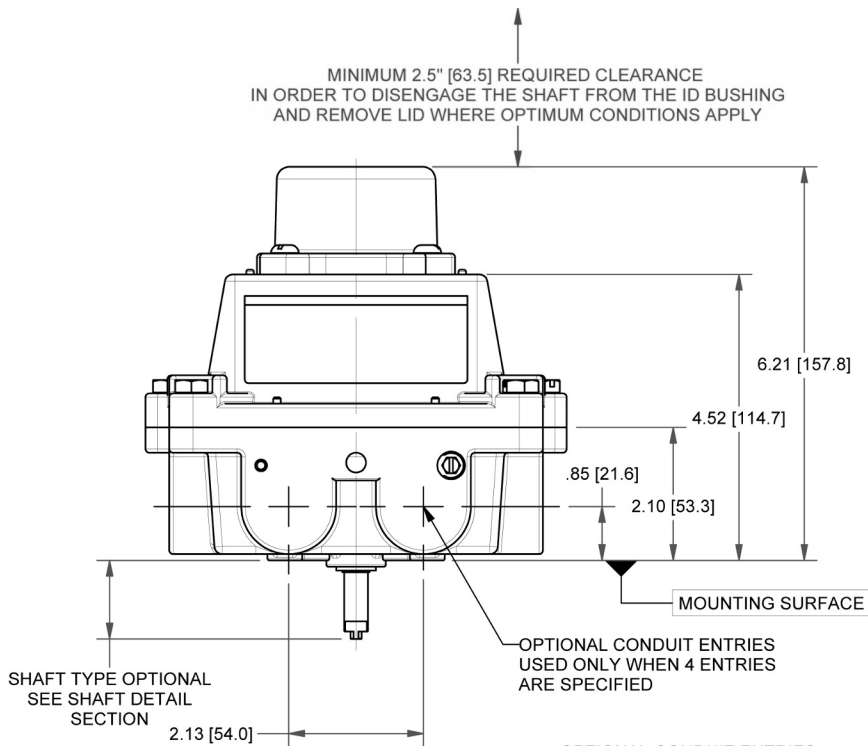

MATERIALS OF CONSTRUCTION	
Enclosure	Cast 316 Stainless Steel
Fasteners	304 Stainless Steel standard 316 Stainless Steel optional
Shaft	304 Stainless Steel standard 316 Stainless Steel optional
Shaft Bushing	N/A
Indicator Dome	Polycarbonate, UV F1 rated
Seals	O-ring seals available in: Buna & Silicone,

Fastener Torque Specifications	
Enclosure Housing Bolts	8 ft.-lbs [10.8 N·m] +/-10%
Indicator Dome Screws	320 in.-oz. [2.3 N·m] +/-10%
Bottom Mounting Holes	10 ft.-lbs [13.6 N·m] +/-10%

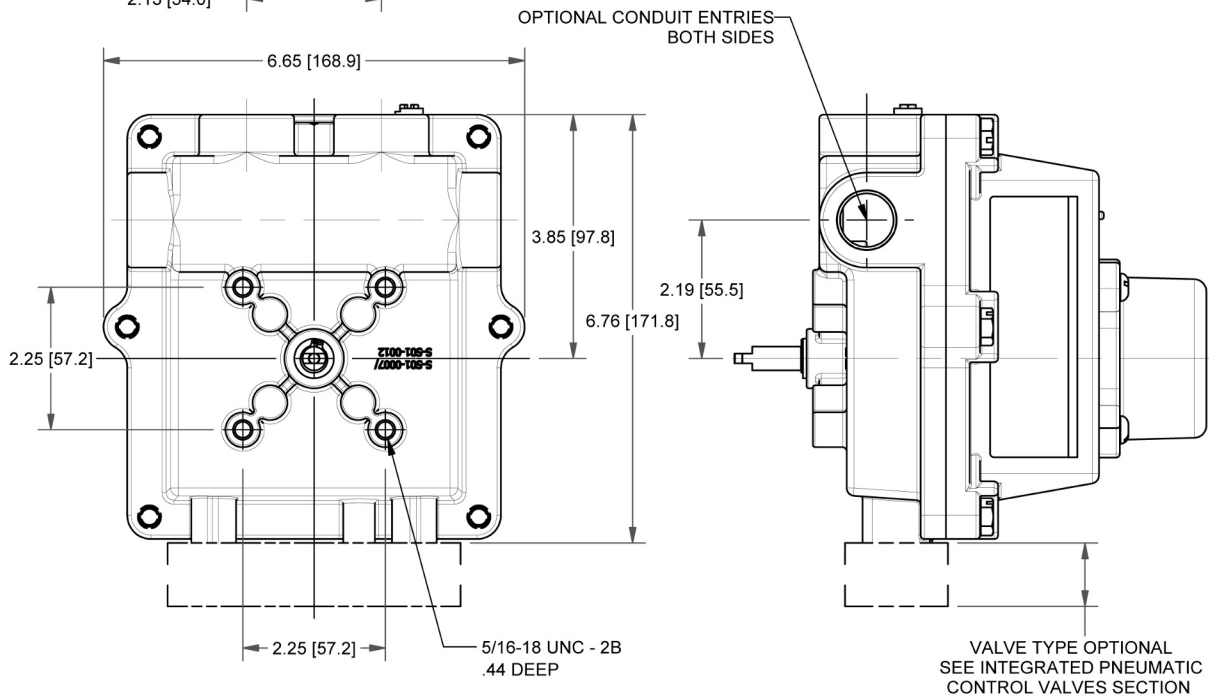

# Dimensions and Materials: TopWorx™ DXR

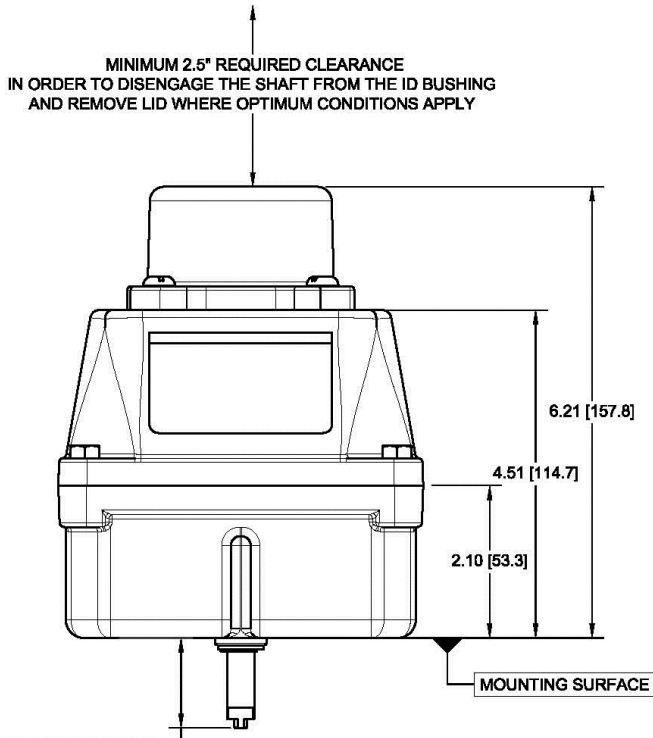

SHAFT TYPE OPTIONAL  
SEE SHAFT DETAIL  
SECTION

MATERIALS OF CONSTRUCTION	
Enclosure	Valox™ 364
Fasteners	304 Stainless Steel standard 316 Stainless Steel optional
Shaft	304 Stainless Steel standard 316 Stainless Steel optional
Shaft Bushing	Delrin™ 500P white
Indicator Dome	Polycarbonate, UV F1 rated
Seals	Silicone

Fastener Torque Specifications	
Enclosure Housing Bolts	20 in-lbs [2.3 N·m] +/-10%
Indicator Dome Screws	20 in-oz. [2.3 N·m] +/-10%
Bottom Mounting Holes	8 ft.-lbs [10.8 N·m] +/-10%

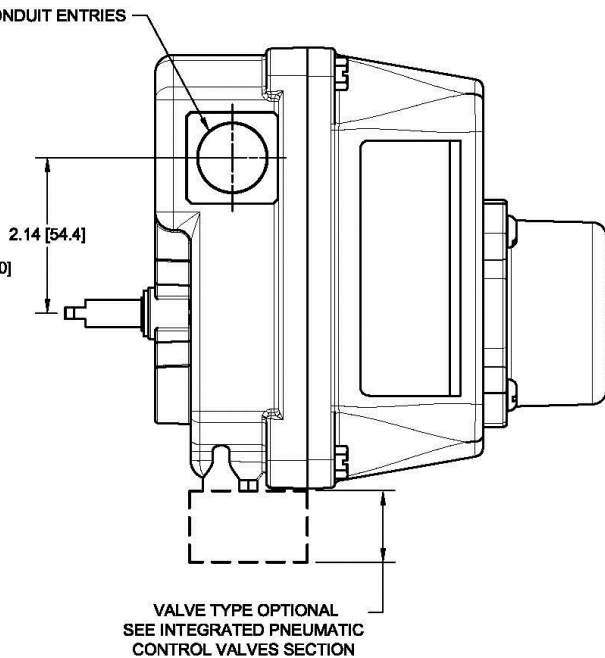
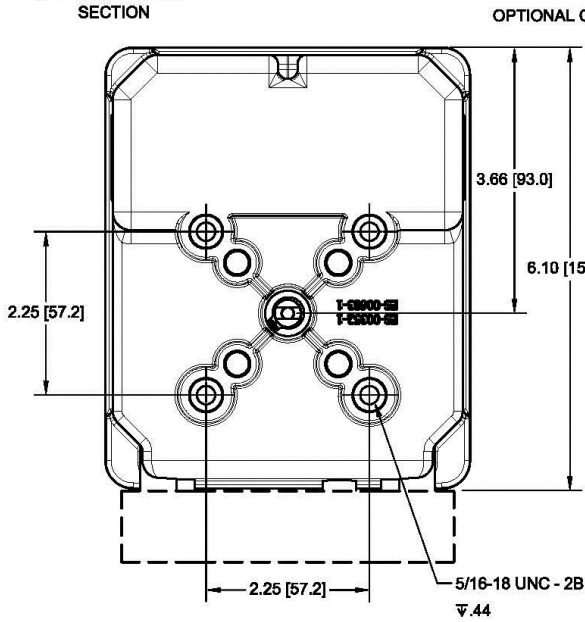

# Indicator Assembly

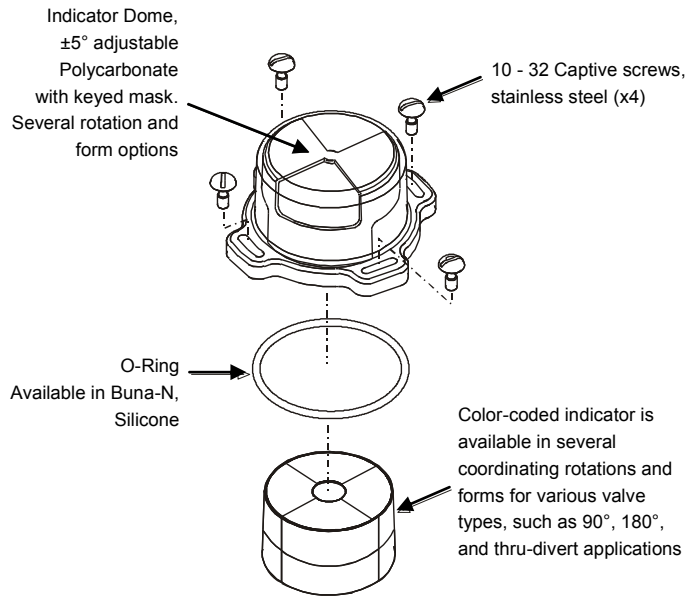

# Cam/Shaft Assemblies

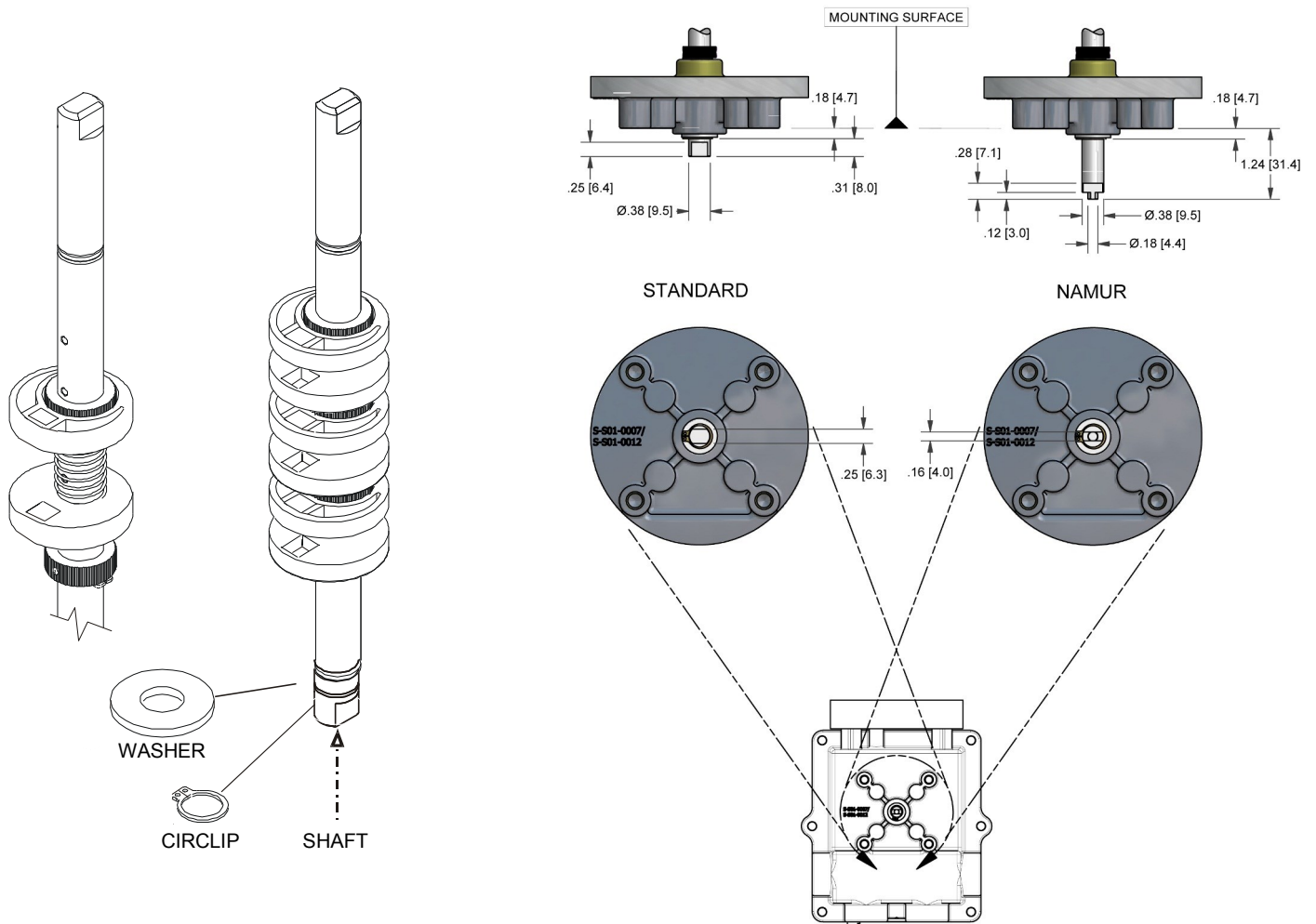

**D-SERIES METAL (DXP/DXS)**

**INTRINSICALLY SAFE (WITHOUT THE VALVE OPTION)**



Ex Ia IIC T8/T4 Ga\*, Ex t IIIC T70°C Db, IP68/IP67  
 Ex Ia IIC T8/T4 Gb\*, Ex t IIIC T70°C Db, IP68/IP67  
 Ex Ia IIC T4, DIP A21 TA 85°C IP68/IP67 (marking for GOST)  
 Ex Ib IIC T4 Gb, Ex tb IIIC T80°C Db, IP67 (marking for FF and FF with FISCO)  
 Class I Div 1, Groups A,B,C,D; Type 4X; IP67  
 Ex Ia IIC T8 Ga, DIP A21 TA, T8/T4 Db IP68/IP67 (marking for NEPSI)  
 -50°C ≤ Tamb ≤ +55°C (maximum\*)  
 SIR A 07ATEX2214X  
 Baseefa 11ATEX0035X (FF and FF with FISCO)  
 IECEX SIR 09.0098X  
 IECEX BAS 11.0022X (FF and FF with FISCO)  
 NCC 12.1280X  
 GOST POCC US.IT606.B01346  
 PESO - P279871/1  
 NEPSI GYJ13.1297X

\* Reference certificates for variations to Tamb and ELP due to sensing and/or o-ring material options.

**INTRINSICALLY SAFE (WITH THE VALVE OPTION)**



Ex Ia IIC T8/T4 Ga/Gb, Ex t IIIC T70°C Db, IP68/IP67  
 Ex Ia IIC T4, DIP A21 TA 85°C IP68/IP67 (marking for GOST)  
 Ex Ib IIC T4 Gb, Ex tb IIIC T80°C Db, IP67 (marking for FF and FF with FISCO)  
 Class I Div 1, Groups A,B,C,D; Type 4,4X; IP67  
 Ex Ia IIC T8/T4 Ga, DIP A21 TA, T8/T4 Db IP68/IP67 (marking for NEPSI)  
 -40°C ≤ Tamb ≤ +60°C (maximum\*)  
 SIR A 07ATEX2214X  
 Baseefa 11ATEX0035X (FF and FF with FISCO)  
 GOST POCC US.IT606.B01346  
 PESO - P279871/1  
 NEPSI GYJ13.1297X

\* Reference certificates for variations to Tamb due to pilot options and ELP due to sensing and/or o-ring material options.

**FLAMEPROOF**



Ex d IIB+H2 T8 Gb  
 Ex tb IIIC T85°C Db, IP68/IP67  
 Ex d IIB+H2 T4, DIP A21 TA 85°C IP68/IP67 (marking for GOST)  
 Class I Div 1, Groups C,D; Class I Div 2, Groups A,B,C,D; Class II Div 2, Groups F,G; Type 4,4X; IP68/IP67  
 Ex d IIB+H2 T8/T8/T4 Gb, DIP A21 TA, T8/T8/T4 Db, IP68/IP67 (marking for NEPSI)  
 Ex d IIB+H2 T8/T8/T4 Gb, Ex ID A21, T85°C/T100°C/T135°C Db, IP68/IP67 (marking for KOSHA)  
 Ex d IIB+H2 T8/T8/T4 Gb, Ex tb IIIC, T85°C/T100°C/T135°C Db, IP68/IP67 (marking for ANZEx)  
 -50°C ≤ Tamb ≤ +60°C (maximum\*)  
 SIR A 07ATEX1273X  
 IECEX SIR 07.0093X  
 NCC 12.1138X  
 GOST POCC US.IT606.B01346  
 PESO - P279873/1  
 NEPSI GYJ13.1295X  
 KOSHA 13-AV480-0003X  
 ANZEx 11.2002X

\* Reference certificates for variations to Tamb.



Ex d IIC T8/T8/T4 Gb  
 Ex tb IIIC T85°C/T100°C/T135°C Db, IP68/IP67  
 Ex d IIC T4, DIP A21 TA 85°C IP68/IP67 (marking for GOST)  
 Ex d IIC T8/T8/T4 Gb, DIP A21 TA, T8/T8/T4 Db, IP68/IP67 (marking for NEPSI)  
 Ex d IIC T8/T8/T4 Gb, Ex ID A21, T85°C/T100°C/T135°C Db, IP68/IP67 (marking for KOSHA)  
 Ex d IIC T8/T8/T4 Gb, Ex tb IIIC, T85°C/T100°C/T135°C Db, IP68/IP67 (marking for ANZEx)  
 -60°C ≤ Tamb ≤ +80°C/75°C/110°C (maximum\*)  
 SIR A 07ATEX1273X  
 IECEX SIR 07.0093X  
 NCC 5614/09X  
 GOST POCC US.IT606.B00921  
 PESO - P279873/1  
 NEPSI GYJ13.1295X  
 KOSHA 13-AV480-0003X  
 ANZEx 11.2002X

\* Reference certificates for variations to Tamb.

**NON-INCENDIVE**



Ex nC IIC T6 Gb; IP68/IP67\*  
 Class I Div 2, Groups A,B,C,D; Class II Div 2, Groups F,G; Type 4X; IP68/IP67  
 -40°C ≤ Tamb ≤ +60°C

\*Consult factory for available sensing options.

**D-SERIES RESIN (DXR)**

**INTRINSICALLY SAFE (WITHOUT THE VALVE OPTION)**



Ex ie IIC T4 Gb, Ex t IIIC T70°C Db, IP67 (Silicone o-rings only)  
 Ex lb IIC T4 Gb, Ex tb IIIC T80°C Db, IP67 (marking for FF only)  
 Ex Ia IIC T8 Ga, DIP A21 TA, T8/T4 Db IP67 (marking for NEPSI)  
 -40°C ≤ Tamb ≤ +53°C (maximum\*)  
 SIR A 07ATEX2214X  
 Baseefa 11ATEX0035X (FF and FF with FISCO)  
 IECEX SIR 09.0098X  
 IECEX BAS 11.0022X (FF and FF with FISCO)  
 NEPSI GYJ13.1297X

\* Reference certificates for variations to Tamb due to sensing options.

**INTRINSICALLY SAFE (WITH THE VALVE OPTION)**



Ex Ia IIC T4 Gb, Ex t IIIC T70°C Db, IP67 (Silicone o-rings only)  
 Ex lb IIC T4 Gb, Ex tb IIIC T80°C Db, IP67 (marking for FF only)  
 Ex Ia IIC T8/T4 Ga, DIP A21 TA, T8/T4 Db IP67 (marking for NEPSI)  
 -20°C ≤ Tamb ≤ +53°C (maximum\*)  
 SIR A 07ATEX2214X  
 Baseefa 11ATEX0035X (FF and FF with FISCO)  
 IECEX SIR 09.0098X  
 IECEX BAS 11.0022X (FF and FF with FISCO)  
 NEPSI GYJ13.1297X

\* Reference certificates for variations to Tamb due to pilot options.

**INCREASED SAFETY (WITH & WITHOUT THE VALVE OPTION)**



Ex e mb IIC T4 Gb  
 Ex tb IIIC T86°C Db, IP67 (Silicone o-rings only)  
 -20°C ≤ Tamb ≤ +44°C (maximum\*)  
 SIR A 09ATEX3208X  
 IECEX SIR 09.0098X  
 P279873/2

\* Reference certificates for variations to Tamb due to pilot options.

**NON-INCENDIVE**



Class I Div 2, Groups A,B,C,D; Class II Div 2, Groups F,G; Type 4,4X; IP67  
 T4 -40°C ≤ Tamb ≤ +80°C

**GENERAL PURPOSE**



Type 4X, IP67

**D-SERIES METAL (DXP/DXS)**

**GENERAL PURPOSE**



Type 4X, IP68/IP67

\*Consult factory for available sensing options.

## Safe Use

### User instructions (in compliance with ATEX 94/9/EC Directive, Annex II, 1.0.6)

#### Instructions for safe selection, installation, use, maintenance and repair

- 1) The equipment may be used in zones 0, 1 or 2.
- 2) The equipment may be used in the presence of flammable gases and vapors with apparatus groups IIC or IIB or IIA and with temperature classes T1 or T2 or T3 or T4 or T5 or T6.
- 3) The equipment is certified for use in ambient temperatures in the range of -50°C to +60°C and should not be used outside this range.  
**(NOTE: Ambient temperature range may change according to protection method)**
- 4) The equipment is to be installed by suitably trained personnel in accordance with the applicable code of practice (typically IEC 60079-14)
- 5) Under certain extreme circumstances, the plastic cover over the valve position indicator may generate an ignition-capable level of electrostatic charge. Therefore, particularly in the event of an installation in zone 0, the equipment shall not be installed in a location where the external conditions are conducive to the build-up of electrostatic charge, e.g. wind-blown dust, etc. Additionally the equipment shall only be cleaned with a damp cloth.
- 6) Periodic inspection of the equipment and system should be performed by suitably trained personnel in accordance with the applicable code of practice (typically IEC 60079-17) to ensure it is maintained in a satisfactory condition.
- 7) The equipment does not require assembly or dismantling.
- 8) The equipment is not intended to be repaired by the user. Repair of the equipment is to be carried out by the manufacturer, or their approved agents, in accordance with the applicable code of practice.

#### Special Conditions of Safe Use (All installations)

Clean only with a damp cloth to prevent possibility of electrostatic discharge.

For Explosion Proof installations, the internal ground connection shall be used and the external ground connection, if supplied in addition, is supplemental bonding allowed where local authorities permit, or is required.

When installing with a third party listed nipple-mount solenoid, it is the responsibility of the installer to provide fittings, and apparatus, suitable for the area classification in accordance with the National Electrical Code.

All cable entry devices or conduit stopping boxes shall be certified according to protection type and suitable for the conditions of use and correctly installed.

The IIC enclosures are excluded from use in carbon disulphide atmospheres.

The air pressure to the valve block, when fitted, shall not exceed 10.0bar.

#### Special Conditions of Safe Use (Flameproof Installations)

1. The IIC enclosures are excluded from use in carbon disulphide atmospheres.
2. The air pressure to the valve block, when fitted, shall not exceed 10.0 bar.
3. For ambient temperatures above 110°C, the degrees of ingress protection IP66 and IP67 are not endorsed.
4. The slotted hexagonal head cover screws are not of standard form; they shall only be replaced with identical screws sourced from the equipment manufacturer.
5. The hexagonal head cover screws are to be replaced only with stainless steel 304, grade A2-70 or A4-80 screws to ISO 35061.
6. Cover fasteners are to be tightened to a torque value of 10.85Nm (8 ft./lbs) minimum.



## Continued

### Special Conditions or Safe Use Continued (Intrinsically Safe Installations)

The D-Series Intrinsically Safe TopWorx™ may contain one or more devices covered by the following certificates:

The installer shall confirm which certified sub-assemblies are contained within the equipment and ensure compliance with the appropriate certificate (with particular reference to input parameters)

Number	Description
PTB 99ATEX2219X plus supplement 1	Pepperl & Fuchs slot-type initiators, types SJ... & SC...
PTB 00ATEX2032X plus Supplements 1 & 2	Pepperl & Fuchs cuboidal inductive sensors, type NJ...
PTB 00ATEX2048X plus Supplements 1, 2 & 3	Pepperl & Fuchs cylindrical inductive sensors, types NC... & NJ...
PTB 00ATEX2049X plus Supplement 1	Pepperl & Fuchs SN sensors, type NJ...
KEMA 02ATEX1090X plus Amendment 1	Turk two-wire proximity sensors type ...-....-Y1.-...../....
PTB 01ATEX2191	IFM inductive proximity switch type NE****, NF****, NG****, NI****, NN****, NT****, NS****
LCIE 02ATEX6122X	Crouzet electro-valve type 81519xxx
Sira 12ATEX2192U	4-20 mA Transmitter Module

1. The 4-20 mA loop circuit and the various additional sub-assemblies (switches, sensors and valves) shall be treated as separate intrinsically safe circuits.
2. The DXR (resin) enclosure shall only be installed where there is a low risk of mechanical damage.
3. The switchbox may contain simple switches, which shall have a maximum input power (Pi) of 1.3 W for T4 or 0.7 W for T6 from an intrinsically safe supply.
4. For a T4 temperature class, the switchbox may contain simple switch and resistor arrangements, which shall have a maximum input power (Pi) of 0.7 W from an intrinsically safe supply. These are not permitted for a T6 temperature class.
5. For a T6 temperature class, the input parameters to sensors covered by PTB 99ATEX2219X, PTB 00ATEX2032X, PTB 00ATEX2048X or PTB 00ATEX2049X shall be limited to  $U_i = 16V$ ,  $I_i = 25mA$ ,  $P_i = 64mW$ .
6. For a T6 temperature class, the Turck proximity sensors listed in certificates KEMA 02ATEX1090X shall have the maximum input parameters as follows:
  - Type AX & GX:  $U_i = 15V$ ,  $I_i = 20mA$ ,  $P_i = 200mW$
  - All other sensors:  $U_i = 15V$ ,  $I_i = 60mA$ ,  $P_i = 130W$
7. When the equipment incorporates a 4-20 mA Transmitter Module (Sira 12ATEX2192U), the manufacturer may apply the marking "II 1G" or "II 2 D" or "II 2 GD". A T6 temperature class is not permitted with this Module fitted. The ambient temperature is limited to a maximum range of -40°C to +53°C, but this range may be reduced, depending on the enclosure and gasket type, as well as the internal sub-assemblies fitted. Additionally, the output from the 4-20mA Transmitter Module shall only be connected to a Novotechnic WAL30 potentiometer

### Preventative Maintenance

The TopWorx™ is designed to operate for one million cycles without servicing. Call the factory when you are approaching this milestone for a preventative maintenance kit and instructions.

## TopWorx™ D-Series Replacement Part Number List

The TopWorx™ is designed to operate for one million cycles without servicing. Call TopWorx™ when you are approaching this milestone for a preventative maintenance kit and instructions.

<b>35 Series GO™ Switches</b>	
35-13319M	Option L2/L4 - SPDT
35-83358M	Option Z2/Z4 - DPDT Stainless Steel
<b>Switch / Module Replacement Kits</b>	
SCM-FF	Foundation Fieldbus module
SCM-AS	AS-Interface module
SCM-DN	DeviceNet module
AV-MSW1	(M) SPDT mechanical switch replacement
AV-E1	(E) P+F NJ2-V3-N sensor replacement
AV-TSW1	(T) DPDT mechanical switch replacement
AV-420TMRK	4-20mA transmitter replacement assembly w/ potentiometer
<b>Indicator / Dome Replacement Kits</b>	
AV-GB002	90°, Green/Open, Red/Closed, Buna O-Ring
AV-YB002	90°, Yellow/Open, Black/Closed, Buna O-Ring
AV-BB002	90°, Black/Open, Yellow/Closed, Buna O-Ring
AV-4B002	45°, Green/Open, Red/Closed, Buna O-Ring
<b>Shaft Replacement Kits Mechanical Switches (M2 or T2)</b>	
AV-SSB201	Standard shaft Buna-N O-Rings & (2) cam Assembly w/ Hardware
AV-NSB201	NAMUR Shaft Buna-N O-Rings & (2) cam Assembly w/ Hardware
<b>Shaft Replacement Kits GO™ Switches (L2 - Manufactured after July 1, 2007)</b>	
AV-SSB205	Standard shaft Buna-N O-Rings & (2) Target Assembly w/ Hardware
AV-SNB205	NAMUR shaft Buna-N O-Rings & (2) Target Assembly w/ Hardware
<b>Shaft Replacement Kits SCMs with Reed Switches (R2)</b>	
AV-NSB202	NAMUR Shaft Buna-N O-Rings & (2) cam Assembly w/ Hardware
AV-SSB202	Standard Shaft Buna-N O-Rings & (2) cam Assembly w/ Hardware

## TopWorx™ D-Series Replacement Part Number List Continued

<b>Pilot Replacement Kits</b>	
AV-S24VPMRK	24vdc pilot/manifold replacement kit
AV-S110VPMRK	110vac pilot/manifold replacement kit
AV-SP20PMRK	Piezo pilot/manifold replacement kit
<b>Spool Valve Replacement Assemblies Fail Closed / No Override</b>	
AV-BFCVA20	Std Alum Spool Valve Assembly w/ Buna seals
AV-BFCVS20	Std 304SS Spool Valve Assembly w/ Buna seals
AV-BFCV620	Std 316SS Spool Valve Assembly w/ Buna seals
<b>Spool Valve Replacement Assemblies Fail Last Position / No Override</b>	
AV-BFLPVA20	Std Alum Spool Valve Assembly w/ Buna seals
AV-BFLPVS20	Std 304SS Spool Valve Assembly w/ Buna seals
AV-BFLPV620	Std 316SS Spool Valve Assembly w/ Buna seals
<b>Spool Valve Replacement Assemblies Block Center / No Override</b>	
AV-BBCVA20	Std Alum Spool Valve Assembly w/ Buna seals
AV-BBCVS20	Std 304SS Spool Valve Assembly w/ Buna seals
AV-BBCV620	Std 316SS Spool Valve Assembly w/ Buna seals

### Consult Factory

To order replacement parts or for information concerning parts or spool valve options not listed call  
**TopWorx™ at 502-969-8000**

## Recommended Operating Temperatures

<b>Flameproof (DXP and DXS Only)</b>			
<b>Option</b>	<b>Switch Description</b>	<b>TopWorx™ with NO Solenoid</b>	<b>TopWorx™ WITH Solenoid</b>
M	Mechanical switch - SPDT	-40°C to +80°C	-20°C to +60°C
K	Mech. switch w/Au contact	-40°C to +80°C	-20°C to +60°C
L	35 GO™ Switch SPDT	-60°C to +80°C	-20°C to +60°C
Z	35 GO™ Switch DPDT	-60°C to +80°C	-20°C to +60°C
R	Reed Switch SPDT	-40°C to +80°C	-20°C to +60°C
T	Mechanical switch DPDT	-40°C to +80°C	-20°C to +60°C
8	Mechanical switch DPDT	-40°C to +80°C	-20°C to +60°C
PS	Reed cube with LED	-40°C to +80°C	-20°C to +60°C
PN	Reed cube w/no LED	-40°C to +80°C	-20°C to +60°C
AS	Asi	-40°C to +80°C	-20°C to +60°C
DN	DeviceNet	-40°C to +80°C	-20°C to +60°C
FF	Foundation Fieldbus	-40°C to +80°C	-20°C to +60°C
MB	Mod Bus	-40°C to +80°C	-20°C to +60°C
_X	4-20mA Transmitter	-40°C to +80°C	-20°C to +60°C
_H	4-20 Xmitter with HART	-40°C to +80°C	-20°C to +60°C
0A	1k potentiometer	-40°C to +80°C	-20°C to +60°C
0B	10k potentiometer	-40°C to +80°C	-20°C to +60°C
<b>PEPPERL+FUCHS SWITCH OPTIONS - STANDARD</b>			
E	NJ2-V3-N	-25°C to +80°C	-20°C to +60°C
F	NJ2-12GK-N	-25°C to +80°C	-20°C to +60°C
B	NJ2-12GK-SN	-40°C to +80°C	-20°C to +60°C
C	NJ2-11-N	-25°C to +80°C	-20°C to +60°C
J	NJ2-11-SN	-40°C to +80°C	-20°C to +60°C
7	NJ2-12GM40-E2	-25°C to +70°C	-20°C to +60°C
V	NJ3-18GK-S1N	-25°C to +80°C	-20°C to +60°C
3	NJ5-30GK-S1N	-25°C to +80°C	-20°C to +60°C
<b>PEPPERL+FUCHS SWITCH OPTIONS - CUSTOM</b>			
<N001>	NCB5-18GM40-NO-V1	-25°C to +80°C	-20°C to +60°C
<N002>	NJ4-12GM-N	-25°C to +80°C	-20°C to +60°C
<N003>	SJ3.5-N	-25°C to +80°C	-20°C to +60°C
<N004>	SJ3.5-SN	-40°C to +80°C	-20°C to +60°C
<N005>	NCN4-12GM35-NO	-25°C to +80°C	-20°C to +60°C
<N006>	NJ2-12GK-SN	-40°C to +80°C	-20°C to +60°C
<N007>	SJ3.5-S1N	-25°C to +80°C	-20°C to +60°C
<N008>	NJ5-18GK-SN	-40°C to +80°C	-20°C to +60°C
<N009>	NJ4-12GK-SN	-40°C to +80°C	-20°C to +60°C
<N010>	NJ5-11-N-G	-25°C to +80°C	-20°C to +60°C
<N011>	NJ2-11-N-G	-25°C to +80°C	-20°C to +60°C
<N012>	NJ3-18GK-S1N	-25°C to +80°C	-20°C to +60°C
<N013>	NJ5-18GK-N	-25°C to +80°C	-20°C to +60°C
<N014>	SC3.5G-N0	-25°C to +80°C	-20°C to +60°C
<N015>	NJ2-12GM-N	-25°C to +80°C	-20°C to +60°C
<N016>	NJ5-18GM-N	-25°C to +80°C	-20°C to +60°C
<N017>	NJ2-12GK-N	-25°C to +80°C	-20°C to +60°C
<N018>	NCB5-18GM40-NO	-25°C to +80°C	-20°C to +60°C
<N019>	NJ2-12GM40-E2	-25°C to +80°C	-20°C to +60°C
<N020>	NCB2-12GM35-N0	-25°C to +80°C	-20°C to +60°C
<N021>	SJ3.5-N-BU	-25°C to +80°C	-20°C to +60°C
<N022>	NBN4-12GM40-Z0	-25°C to +80°C	-20°C to +60°C
<N023>	NJ2-11-SN-G	-40°C to +80°C	-20°C to +60°C
<N024>	NBB5-18GM40-Z0	-25°C to +70°C	-20°C to +60°C
<N025>	NCB2-12GM40-Z0	-25°C to +70°C	-20°C to +60°C
<N026>	NJ4-12GK-N	-25°C to +80°C	-20°C to +60°C

## Recommended Operating Temperatures Continued

<b>Intrinsically Safe</b>					
<b>Option</b>	<b>Switch Description</b>	<b>DXP/DXS</b>		<b>DXR</b>	
		<b>TopWorx™ w/o Solenoid</b>	<b>TopWorx™ w/Solenoid</b>	<b>TopWorx™ w/o Solenoid</b>	<b>TopWorx™ w/Solenoid</b>
M	Mechanical switch - SPDT	-40°C to +55°C	-10°C to +50°C	-20°C to +53°C	-10°C to +50°C
K	Mech. switch w/Au contact	-40°C to +55°C	-10°C to +50°C	-20°C to +53°C	-10°C to +50°C
L	35 GO™ Switch SPDT	-60°C to +55°C	-10°C to +50°C	-20°C to +53°C	-10°C to +50°C
Z	35 GO™ Switch DPDT	-60°C to +55°C	-10°C to +50°C	-20°C to +53°C	-10°C to +50°C
R	Reed Switch SPDT	-30°C to +55°C	-10°C to +50°C	-20°C to +53°C	-10°C to +50°C
T	Mechanical switch DPDT	not available	not available	not available	not available
8	Mechanical switch DPDT	-20°C to +50°C	-10°C to +50°C	-20°C to +53°C	-10°C to +50°C
PS	Reed cube with LED	not available	not available	not available	not available
PN	Reed cube w/no LED	-30°C to +55°C	-10°C to +50°C	not available	not available
AS	Asi	not available	not available	not available	not available
DN	DeviceNet	not available	not available	not available	not available
FF	Foundation Fieldbus	-40°C to +80°C	-20°C to +80°C	-20°C to +80°C	-20°C to +80°C
MB	Mod Bus	not available	not available	not available	not available
_X	4-20mA Transmitter	not available	not available	not available	not available
_H	4-20 Xmitter with HART	-40°C to +55°C	-10°C to +50°C	-40°C to +55°C	-10°C to +50°C
0A	1k potentiometer	-40°C to +55°C	-10°C to +50°C	not available	not available
0B	10k potentiometer	-40°C to +55°C	-10°C to +50°C	not available	not available
<b>PEPPERL+FUCHS SWITCH OPTIONS - STANDARD</b>					
E	NJ2-V3-N	-25°C to +55°C	-10°C to +50°C	-20°C to +53°C	-10°C to +50°C
F	NJ2-12GK-N	-25°C to +55°C	-10°C to +50°C	-20°C to +53°C	-10°C to +50°C
B	NJ2-12GK-SN	-40°C to +55°C	-10°C to +50°C	-20°C to +53°C	-10°C to +50°C
C	NJ2-11-N	-25°C to +55°C	-10°C to +50°C	-20°C to +53°C	-10°C to +50°C
J	NJ2-11-SN	-40°C to +55°C	-10°C to +50°C	-20°C to +53°C	-10°C to +50°C
7	NJ2-12GM40-E2	-25°C to +55°C	-10°C to +50°C	-20°C to +53°C	-10°C to +50°C
V	NJ3-18GK-S1N	-25°C to +55°C	-10°C to +50°C	-20°C to +53°C	-10°C to +50°C
3	NJ5-30GK-S1N	-25°C to +55°C	-10°C to +50°C	-20°C to +53°C	-10°C to +50°C
<b>PEPPERL+FUCHS SWITCH OPTIONS - CUSTOM</b>					
<N001>	NCB5-18GM40-NO-V1	-25°C to +40°C	-10°C to +40°C	-20°C to +53°C	-10°C to +50°C
<N002>	NJ4-12GM-N	-25°C to +40°C	-10°C to +40°C	-20°C to +53°C	-10°C to +50°C
<N003>	SJ3.5-N	-25°C to +60°C	-10°C to +60°C	-20°C to +53°C	-10°C to +50°C
<N004>	SJ3.5-SN	-50°C to +40°C	-10°C to +40°C	-20°C to +53°C	-10°C to +50°C
<N005>	NCN4-12GM35-NO	-25°C to +40°C	-10°C to +40°C	-20°C to +53°C	-10°C to +50°C
<N006>	NJ2-12GK-SN	-25°C to +40°C	-10°C to +40°C	-20°C to +53°C	-10°C to +50°C
<N007>	SJ3.5-S1N	-25°C to +40°C	-10°C to +40°C	-20°C to +53°C	-10°C to +50°C
<N008>	NJ5-18GK-SN	-40°C to +40°C	-10°C to +40°C	-20°C to +53°C	-10°C to +50°C
<N009>	NJ4-12GK-SN	-50°C to +40°C	-10°C to +40°C	-20°C to +53°C	-10°C to +50°C
<N010>	NJ5-11-N-G	-25°C to +40°C	-10°C to +40°C	-20°C to +53°C	-10°C to +50°C
<N011>	NJ2-11-N-G	-25°C to +40°C	-10°C to +40°C	-20°C to +53°C	-10°C to +50°C
<N012>	NJ3-18GK-S1N	-25°C to +40°C	-10°C to +40°C	-20°C to +53°C	-10°C to +50°C
<N013>	NJ5-18GK-N	-25°C to +40°C	-10°C to +40°C	-20°C to +53°C	-10°C to +50°C
<N014>	SC3.5G-N0	-25°C to +60°C	-10°C to +60°C	-20°C to +53°C	-10°C to +50°C
<N015>	NJ2-12GM-N	-25°C to +40°C	-10°C to +40°C	-20°C to +53°C	-10°C to +50°C
<N016>	NJ5-18GM-N	-25°C to +40°C	-10°C to +40°C	-20°C to +53°C	-10°C to +50°C
<N017>	NJ2-12GK-N	-25°C to +40°C	-10°C to +40°C	-20°C to +53°C	-10°C to +50°C
<N018>	NCB5-18GM40-NO	-25°C to +40°C	-10°C to +40°C	-20°C to +53°C	-10°C to +50°C
<N019>	NJ2-12GM40-E2	not available	not available	not available	not available
<N020>	NCB2-12GM35-N0	-25°C to +40°C	-10°C to +40°C	-20°C to +53°C	-10°C to +50°C
<N021>	SJ3.5-N-BU	-25°C to +60°C	-10°C to +60°C	-20°C to +53°C	-10°C to +50°C
<N022>	NBN4-12GM40-Z0	not available	not available	not available	not available
<N023>	NJ2-11-SN-G	-40°C to +40°C	-10°C to +40°C	-20°C to +53°C	-10°C to +50°C
<N024>	NBB5-18GM40-Z0	not available	not available	not available	not available
<N025>	NCB2-12GM40-Z0	not available	not available	not available	not available
<N026>	NJ4-12GK-N	-25°C to +40°C	-10°C to +40°C	-20°C to +53°C	-10°C to +50°C

# Warranty

## TERMS AND CONDITIONS OF SALE

## EXHIBIT C

These terms and conditions, the attendant quotation or acknowledgment, and all documents incorporated by reference therein, binds TopWorx, Inc. hereinafter the Seller, and the buyer, hereinafter Buyer, and constitutes the entire agreement (Agreement) between Buyer and Seller for the provision of services (Services) and/or the sale of goods (Goods) including (except as provided in Section 10) firmware incorporated therein.

**1. PRICES:** Unless otherwise specified by Seller, Seller's price for the Goods and/or Services shall remain in effect for thirty (30) days after the date of Seller's quotation or acceptance of the order for the Goods/Services, whichever is delivered first, provided an unconditional, complete authorization for the immediate manufacture and shipment of the Goods and/or provision of Services pursuant to Seller's standard order processing procedures is received and accepted by Seller within such time period. If such authorization is not received by Seller within such thirty (30) day period, Seller shall have the right to change the price for the Goods/Services to Seller's price in effect for the Goods/Services at the time the order is released to final manufacture. Prices for Goods do not cover storing, installing, starting up or maintaining Goods unless expressly stated in Seller's quotation. Notwithstanding the foregoing, the price for Goods/Services sold by Seller, but manufactured by others, shall be Seller's price in effect at the time of shipment to Buyer.

**2. DELIVERY, ORDER ACCEPTANCE AND DOCUMENTATION:** All shipping dates are approximate and are based upon Seller's prompt receipt of all necessary information from Buyer to properly process the order. Notwithstanding any provisions to the contrary in this or other documents related to this transaction, and regardless of how price was quoted, whether FOB, FAS, CIF or otherwise, legal title to the Goods and risk of loss thereto shall transfer to Buyer as follows: for sales in which the end destination of the Goods is within the United States, upon delivery to the freight carrier at the shipping point; for sales in which the end destination of the Goods is outside of the United States, immediately after the Goods have passed beyond the territorial limits of the United States. Seller shall provide Buyer with that data/documentation which is specifically identified in the quotation. If additional copies of data/documentation or non-standard data/documentation are to be provided by Seller, they shall be provided to Buyer at Seller's price then in effect. Data/documentation marked as confidential or proprietary may not be reproduced or used for any purpose other than the purpose for which it was provided and may not be disclosed to third parties without the prior written permission of Seller.

**3. EXCUSE OF PERFORMANCE:** Seller shall not be liable for delays in performance or for non-performance due to failure or interruption of computer or telecommunication systems, acts of God, war, riot, fire, terrorism, labor trouble, unavailability of materials or components, explosion, accident, compliance with governmental requests, laws, regulations, orders or actions, or other unforeseen circumstances or causes beyond Seller's reasonable control. In the event of such delay, the time for performance or delivery shall be extended by a period of time reasonably necessary to overcome the effect of the delay.

**4. TERMINATION AND SUSPENSION BY BUYER:** Buyer may terminate or suspend its order for any or all of the Goods/Services covered by the Agreement provided that Buyer gives Seller reasonable advance written notice of such termination or suspension and reimburses Seller for all losses, damages, costs and expenses arising from such termination or suspension.

**5. LIMITED WARRANTY:** Subject to the limitations contained in Section 6 herein, Seller warrants that the licensed firmware embodied in the Goods will execute the programming instructions provided by Seller, and that the Goods manufactured or Services provided by Seller will be free from defects in materials or workmanship under normal use and care. The foregoing warranties will apply until the expiration of the applicable warranty period. All other Goods are warranted for twelve (12) months from the date of shipment by Seller. Consumables and Services are warranted for a period of 90 days from the date of shipment or completion of the Services. Products purchased by Seller from a third party for resale to Buyer ("Resale Products") shall carry only the warranty extended by the original manufacturer. Buyer agrees that Seller has no liability for Resale Products beyond making a reasonable commercial effort to arrange for procurement and shipping of the Resale Products. If Buyer discovers any warranty defects and notifies Seller thereof in writing during the applicable warranty period, Seller shall, at its option, correct any errors that are found by Seller in the firmware or Services or repair or replace F.O.B. point of manufacture that portion of the Goods or firmware found by Seller to be defective, or refund the purchase price of the defective portion of the Goods/Services. All replacements or repairs necessitated by inadequate maintenance, normal wear and usage, unsuitable power sources or environmental conditions, accident, misuse, improper installation, modification, repair, use of unauthorized replacement parts, storage or handling, or any other cause not the fault of Seller are not covered by this limited warranty, and shall be at Buyer's expense. Seller shall not be obligated to pay any costs or charges incurred by Buyer or any other party except as may be agreed upon in writing in advance by Seller. All costs of dismantling, reinstallation and freight and the time and expenses of Seller's personnel and representatives for site travel and diagnosis under this warranty clause shall be borne by Buyer unless accepted in writing by Seller. Goods repaired and parts replaced by Seller during the warranty period shall be in warranty for the remainder of the original warranty period or ninety (90) days, whichever is longer. This limited warranty is the only warranty made by Seller and can be amended only in a writing signed by Seller. THE WARRANTIES AND REMEDIES SET FORTH ABOVE ARE EXCLUSIVE. THERE ARE NO REPRESENTATIONS OR WARRANTIES OF ANY KIND, EXPRESS OR IMPLIED, AS TO MERCHANTABILITY, FITNESS FOR PARTICULAR PURPOSE OR ANY OTHER MATTER WITH RESPECT TO ANY OF THE GOODS OR SERVICES.

**6. LIMITATION OF REMEDY AND LIABILITY:** SELLER SHALL NOT BE LIABLE FOR DAMAGES CAUSED BY DELAY IN PERFORMANCE. THE REMEDIES OF BUYER SET FORTH IN THIS AGREEMENT ARE EXCLUSIVE. IN NO EVENT, REGARDLESS OF THE FORM OF THE CLAIM OR CAUSE OF ACTION (WHETHER BASED IN CONTRACT, INFRINGEMENT, NEGLIGENCE, STRICT LIABILITY, OTHER TORT OR OTHERWISE), SHALL SELLER'S LIABILITY TO BUYER AND/OR ITS CUSTOMERS EXCEED THE PRICE TO BUYER OF THE SPECIFIC GOODS MANUFACTURED OR SERVICES PROVIDED BY SELLER GIVING RISE TO THE CLAIM OR CAUSE OF ACTION. BUYER AGREES THAT IN NO EVENT SHALL SELLER'S LIABILITY TO BUYER AND/OR ITS CUSTOMERS EXTEND TO INCLUDE INCIDENTAL, CONSEQUENTIAL OR PUNITIVE DAMAGES. THE TERM "CONSEQUENTIAL DAMAGES" SHALL INCLUDE, BUT NOT BE LIMITED TO, LOSS OF ANTICIPATED PROFITS, REVENUE OR USE AND COSTS INCURRED INCLUDING WITHOUT LIMITATION FOR CAPITAL, FUEL AND POWER, AND CLAIMS OF BUYER'S CUSTOMERS.

**7. PATENTS:** Subject to the limitations contained in Section 6, Seller shall defend any suits brought against Buyer based on a claim that use of the Goods manufactured by Seller constitutes an infringement of a valid patent of the United States, and shall pay any damages awarded therein against Buyer, provided that Buyer promptly notifies Seller in writing of the filing of such suit or the threat thereof; permits Seller to control completely the defense or compromise of such claim of infringement; and provides all reasonable assistance and cooperation requested by Seller for the defense of such suit. In the event that only the Goods manufactured by Seller are held to be infringing in such suit and their use is enjoined, Seller shall, at its sole option and expense, provide a commercially reasonable alternative, including, but not limited to, procuring for Buyer the right to continue using the Goods, replacing them with a non-infringing product or modifying them so they become non-infringing. Buyer agrees that Seller shall not be liable for infringement, and that Buyer shall fully indemnify Seller therefore, if infringement is based upon the use of Goods in connection with goods not manufactured by Seller or in a manner for which the Goods were not designed by the Seller or if the Goods were not designed by the Seller or if the Goods were designed by the Buyer or were modified by or for the Buyer in a manner to cause them to become infringing.

**8. TAXES:** Any tax or governmental charge payable by the Seller because of the manufacture, sale or delivery of the Goods, or provision of Services, may at Seller's option be added to the price herein specified. The foregoing shall not apply to taxes based upon Seller's net income.

**9. TERMS OF PAYMENT:** Subject to the approval of Seller's Credit Department, terms are F.O.B. shipping point, net 30 days from date of Seller's invoice in U.S. currency, except for applicable milestone payments covered below or export shipments for which Seller may require other arrangements. Freight charges may include shipping and handling charges, and Buyer shall pay all such charges. If any payment owed to Seller hereunder is not paid when due, it shall bear interest at a rate 1-1/2% per month interest from the date on which it is due until it is received and future shipments may be placed on hold. Seller shall have the right, among other remedies, either to terminate the Agreement or to suspend further deliveries under this and/or other agreements with Buyer in the event Buyer fails to make any payment hereunder when due. Buyer shall be liable for all expenses attendant to collection of past due amounts, including attorneys' fees. Unless otherwise provided in Seller's written quotation, periodic milestone payments shall be made by Buyer when the purchase price of this Agreement exceeds \$100,000. In such cases, invoices shall be issued by Seller and paid by Buyer based on the following milestones: Milestone 1: 30% of price upon acceptance of order by Seller. Milestone 2: 30% of price upon release by Seller of approved bills of material to manufacturing for assembly. Milestone 3: 40% of price upon shipment of the Goods by Seller. Seller reserves the right to designate additional Milestones where the Agreement provides for Services in excess of \$50,000.

**10. SOFTWARE AND FIRMWARE:** Notwithstanding any other provision herein to the contrary, Seller or applicable third party owner shall retain all rights of ownership and title in its respective firmware and software, including all copyrights relating to such firmware and software and all copies of such firmware and software. Except as otherwise provided herein, Buyer is hereby granted a nonexclusive, royalty free license to use firmware and software, and copies of firmware and software, incorporated into the Goods only in conjunction with such Goods and only at the Buyer's plant site where the Goods are first used. Buyer may negotiate with Seller separate licenses to use such copies and firmware and software at other plant sites. Buyer's use of certain firmware (as specified by Seller) and all other software shall be governed exclusively by Seller's and/or third party owner's applicable license terms.

**11. BUYER SUPPLIED DATA:** To the extent that Seller has relied upon any specifications, information, representation of operating conditions or other data or information supplied by Buyer to Seller ("Data") in the selection or design of the Goods and/or provision of the Services and the preparation of Seller's quotation, and in the event that actual operating conditions or other conditions differ from those represented by Buyer and relied upon by Seller, any warranties or other provisions contained herein which are affected by such conditions shall be null and void.

**12. EXPORT/IMPORT:** Buyer agrees that all applicable import and export control laws, regulations, orders and requirements, including without limitation those of the United States and the European Union, and the jurisdictions in which the Seller and Buyer are established or from which items may be supplied will apply to its receipt and use of Goods and Services. In no event shall Buyer use, transfer, release, import, export, or re-export Goods in violation of such applicable laws, regulations, orders, or requirements.

**13. GENERAL PROVISIONS:** (a) Buyer shall not assign its rights or obligations under the Agreement without Seller's prior written consent; (b) there are no understandings, agreements or representations, express or implied, not specified in the Agreement; (c) no action, regardless of form, arising out of transactions under the Agreement, may be brought by either party more than two years after the cause of action has accrued; (d) any modification of these terms and conditions must be set forth in a written instrument signed by a duly authorized representative of Seller; (e) the Agreement is formed and shall be construed, performed and enforced under the laws of the State of Missouri (however, Buyer and Seller agree that the proper venue for all actions arising under the Agreement shall be only in the State where the Goods involved in such actions were manufactured); (f) The 1980 United Nations Convention on Contracts for the International Sale of Goods does not apply to this Agreement; (g) If any provision of the Agreement is invalid under any statute or rule of law, such provision, to that extent only, shall be deemed to be omitted without affecting the validity of the remainder of the Agreement; (h) Seller specifically objects to the application of any Federal Acquisition Regulation ("FAR") or other governmental procurement provision or clause to the Agreement; (i) UNLESS OTHERWISE SPECIFICALLY PROVIDED IN SELLER'S QUOTATION, GOODS AND SERVICES HEREUNDER ARE NOT INTENDED FOR USE IN ANY NUCLEAR OR NUCLEAR RELATED APPLICATIONS. Buyer (i) accepts Goods and Services in accordance with the restriction set forth in the immediately preceding sentence, (ii) agrees to communicate such restriction in writing to any and all subsequent purchasers or users and (iii) agrees to defend, indemnify and hold harmless Seller from any and all claims, losses, liabilities, suits, judgments and damages, including incidental and consequential damages, arising from use of Goods and Services in any nuclear or nuclear related applications, whether the cause of action be based in tort, contract or otherwise, including allegations that the Seller's liability is based on negligence or strict liability; (j) The rights, remedies and protections afforded to Seller under this Agreement, including but not limited to indemnification of Seller, limitation of remedy and liability and limited warranty shall extend to Seller and to its affiliates, subsidiaries, or related companies performing or supplying work, services, or products under this Agreement or any agreement into which it is incorporated by reference; and (k) Seller does not agree to: (i) indemnify Buyer; or (ii) name Buyer as an additional insured.





## GLOBAL SUPPORT OFFICES

### **North America**

3300 Fern Valley Road  
Louisville, Kentucky 40213 USA  
1 502 969 8000  
info.topworx@emerson.com

### **Asia-Pacific**

1 Pandan Crescent  
Singapore 128461  
65 6777 8211  
info.topworx@emerson.com

### **Europe**

Horsfield Way  
Bredbury Industrial Estate  
Stockport  
SK6 2SU UK  
44 0161 406 5155  
info.topworx@emerson.com

### **Middle East**

P.O. Box 17033  
Jebel Ali Free Zone –South 2  
Dubai 17033  
United Arab Emirates  
9714 8118283  
info.topworx@emerson.com

### **Africa**

24 Angus Crescent  
Longmeadow Business Estate East  
Modderfontein  
Gauteng  
South Africa  
27 011 451 3700  
info.topworx@emerson.com

Visit [www.topworx.com](http://www.topworx.com) for comprehensive information on our company, capabilities, and products – including model numbers, data sheets, specifications, dimensions, and certifications.

[info.topworx@emerson.com](mailto:info.topworx@emerson.com)

**[www.topworx.com](http://www.topworx.com)**

The Emerson logo is a trademark and a service mark of Emerson Electric Co. ©2014 Emerson Electric Co. ©2014 TopWorx™, All rights reserved. TopWorx™, and GO™ Switch are trademarks of TopWorx™. All other marks used in this document are the property of their respective owners. Information contained herein - including product specifications is subject to change without notice.



ES-01857-1 R17

**EMERSON. CONSIDER IT SOLVED.™**