



PanaFlow™ MV82

Insertion style multivariable flowmeter

Key benefits

- Multivariable vortex flowmeter for measuring volumetric flow, temperature, pressure, density, and mass flow using a single meter
- Advanced design and digital signal processing for vibration isolation
- Cost effective, accurate and reliable meter for volumetric and mass flow measurement in most gases, liquids and steam without the need to recalibrate
- Energy management through accurate measurement of both temperature and mass flow simultaneously
- Remote monitoring and integration to DCS using HART®, Modbus®, and BACnet® communication protocols
- Significant cost savings through reduced installation costs, wiring runs and services support using MV meter with no moving parts.
- Certified for division 1/Zone 1 explosive atmospheres – US/CAN/ATEX/IEC Ex

Applications

- Ideal for high temperature and high velocity steam
- Power generation—fuel and steam applications
- Industrial—HVAC, district energy management
- Commercial—building, campus and facility energy management
- Oil and gas—allocation of natural gas
- Petrochemical—mass balancing, reaction processes heating

Unique multivariable design

Panametrics, a Baker Hughes business, PanaFlow MV82 in-line multivariable mass vortex flowmeter is the next generation vortex meter. PanaFlow MV82's multivariable design consists of a vortex shedding velocity sensor, an RTD temperature sensor and a solid state pressure transducer that measures the mass flow rate of steam, gases and liquids. Other meter types use external process measurements to calculate mass flow. The temperature and pressure devices are typically not installed in the same location as the flowmeter. Process conditions can vary greatly between the two locations, causing inaccurate mass flow readings. PanaFlow MV82 measures velocity, temperature and pressure at the same location, which provides more accurate process measurement.

Portfolio of flow meter solutions

Panametrics is committed to providing customers with the best technologies for their flow measurement needs. PanaFlow MV82 is the newest addition to the PanaFlow family of flowmeters, providing effective solutions for smaller pipe sizes for a variety of applications. Panametrics offers the PanaFlow MV82 in a number of configurations to best suit your application measurement needs.

Field service solutions

Panametrics has a global field service team ready to assist in the start-up and commissioning of the PanaFlow MV82 flowmeters. This service includes validating the proper installation and programming of the meter, and can include customized training for theory, operation and maintenance. Regularly scheduled preventative maintenance visits will provide peace of mind, ensuring that the meters work to specification and your expectation for years.

Mass flow measurement—true multivariable

The MV82 offers flow computer functionality in a compact field device. The VTP option incorporates temperature and pressure sensors to provide an instantaneous reading of compensated mass flow rate of gases, liquids and steam. In addition to outputs for totalized mass and alarm settings, the field configurable electronics deliver up to three analog 4-20 mA outputs of five process measurements, including volumetric flow rate, mass flow rate, pressure, temperature and density. Alternate configurations for mass flow include a temperature only compensation (VT), best used when in saturated steam applications, and an integrated RTD with an external pressure transmitter (VT-EP) when a full function pressure transmitter is desired.

Energy measurement in liquids and steam

The VT-EM energy monitoring option enables real time-of-flight diffraction calculation of energy consumption for a facility or process. The meter can be programmed to measure steam, hot water or chilled water. This option uses the MV82 flowmeter to monitor one side of the process, either sent or return, and uses the input from a second separate temperature sensor on the opposite leg of the process to calculate the change in energy. Selectable energy units include BTU, joules, calories, watt-hours, megawatt-hours and horsepower-hours. The local or remote electronics indicate two temperatures, delta T, mass total and energy total. For energy measurement in steam, the VTP-EM option adds a pressure transmitter to offer better accuracy.

Volumetric flow for most gases and liquids

The base model MV82 delivers a direct reading of volumetric flow rate—generally the most cost-effective solution for liquid flow monitoring—in applications ranging from general water flows to hydrocarbon fuel flow measurement.

Model	Configuration	Volumetric flow	Mass flow	Integrated RTD	Integrated pressure	External temperature	External pressure	Typical application	Pipe size*
MV82-V	Volumetric flow for liquid and gas	X						Liquid volumetric flow	2" to 72"
MV82-VT	Mass flow with temperature and assumed saturated steam	X	X	X				Saturated steam and liquid mass flow	2" to 72"
MV82-VTP	Mass flow with integrated temperature and Pressure in one device	X	X	X	X			Steam and gases mass flow	2" to 72"
MV82-VT-EP	Mass flow with integrated temperature and analog input for an external pressure transmitter	X	X	X			X	Steam and gases mass flow (special material, high pressure)	2" to 72"
MV82-VT-EM	Energy using integrated temperature and one input for an RTD transmitter	X		X		X		Saturated steam and liquid energy	2" to 72"
MV82-VTP-EM	Energy for steam with integrated pressure and temperature and one input for an RTD transmitter	X	X	X	X	X		Steam energy	2" to 72"

Specifications

Performance

Accuracy

Mass flow rate accuracy for gas and steam based on 50-100% of pressure range

PanaFlow MV82 flow meter accuracy		
Process variable	Liquids	Gas and steam
Volumetric flow rate	± 1.2% of rate	± 1.5% of rate
Mass flow rate	± 1.5% of rate	± 2% of rate
Temperature	± 2°F (± 1°C)	± 2°F (± 1°C)
Pressure	± 0.3% of full scale	± 0.3% of full scale
Density	± 0.3% of reading	± 0.5% of reading

Repeatability

Mass flow rate	±0.2% of rate
Volumetric flow rate	±0.1% of rate
Temperature	±0.2°F (± 0.1°C)
Pressure	±0.05% of full scale
Density	±0.1% of reading

Stability over 12 months

Mass flow rate	±0.2% of rate
Volumetric flow rate	negligible
Temperature	±0.9°F (± 0.5°C)
Pressure	±0.1% of full scale
Density	±0.1% of reading

Response time

Adjustable from 1 to 100 seconds

Operating

Process and ambient temperature

Process standard temperature (code ST)	-40 to 500°F (-40 to 260°C)
Process high temperature (code HT)	Up to 750°F (400°C)
Ambient operating	-5 to 185°F (-20 to 85°C)
Ambient storage	-40 to 185°F (-40 to 85°C)

Pressure transducer ratings			
Full scale operating pressure		Max. over-range pressure	
psia	bara	psia	bara
30	2	60	4
100	7	200	14
300	20	600	40
500	35	1000	70
1500	100	2500	175

Pressure ratings			
Style connection	Process	Rating	Ordering
	2-inch (50mm) Male NPT	ANSI 600 lb	CNPT
	2-inch 150 lb (50mm 70kg) flange	ANSI 150 lb -- PN 16	C150
	2-inch 300 lb (50mm 135kg) flange	ANSI 300 lb -- PN 40	C300
	2-inch 600 lb (50mm 275kg) flange	ANSI 600 lb -- PN 64	C600
Packing gland			
	2-inch (50mm) Male NPT	50 psig (3.5 barg)	PNPT
	2-inch 150 lb (50mm 70kg) flange	50 psig (3.5 barg)	P150
	2-inch 300 lb (50mm 135kg) flange	50 psig (3.5 barg)	P300
Packing gland and removable retractor			
	2-inch (50mm) Male NPT	ANSI 300 lb (135kg)	PNPT and RR
	2-inch 150 lb (50mm 70kg) flange	ANSI 150 lb (70kg)	P150 and RR
	2-inch 300 lb (50mm 135kg) flange	ANSI 300 lb (135kg)	P300 and RR
Packing gland and permanent retractor			
	2-inch (50mm) Male NPT	ANSI 600 lb (275kg)	PNPTR
	2-inch 150 lb (50mm 70kg) flange	ANSI 150 lb (70kg)	P150R
	2-inch 300 lb (50mm 135kg) flange	ANSI 300 lb (135kg)	P300R
	2-inch 600 lb (50mm 275kg) flange	ANSI 600 lb (275kg)	P600R

Power requirements

Model MV82-V: 12-36 VDC loop powered
 Model MV82-VTP, DC option: 12-36 VDC, 100 mA max
 Model MV82-VTP, AC option: 85-240 VAC, 50/60 Hz, 1 watt
 Model MV82-VTP, DC4POE option: 12-28 VDC or power over ethernet (5 watts maximum)

Display

Alphanumeric 2 line x 16 character LCD digital display
 Six pushbuttons for full field configuration
 Pushbuttons can be operated with magnetic wand without removal of enclosure covers
 Display can be mounted in 90° intervals for better viewing

Output signals

Analog: 4–20 mA, loop powered for volumetric meters
 Alarm: Solid state relay, 40 VDC
 Totalizer Pulse: 50 millisecond, 40 VDC
 Volumetric: One analog, one totalizer pulse, HART
 Multivariable: Up to three analog signals, three alarms, one totalizer pulse, HART
 Multivariable option: HART, Modbus RTU, Modbus TCP/IP, BACnet/MSTP, BACnet TCP/IP

Physical

Wetted materials

316L stainless steel, plus:

- PTFE-based thread sealant on models with pressure transducer
- PTFE packing on standard temperature models with packing gland
- Graphite-based packing on high temperature models with packing gland

Certifications

Explosion-proof for Class I, Division 1, Groups B, C & D
 Dust-ignitionproof for Class II, III, Division 1, Groups E, F & G
 Type 4x and IP66
 T6 Temperature Class at -40°C - +70°C
 KEMA ATEX/IEC Ex Approvals II 2 G Ex d IIB + H2 T6
 II 2 D Ex tD A21 IP66 T85°C

Sizing considerations

Piping conditions		
Condition	Pipe diameters, D	
	Upstream	Downstream
One 90° elbow before meter	10D	5D
Two 90° elbows before meter	15D	5D
Two 90° elbows before meter, out of plane	25D	5D
Reduction before meter	10D	5D
Expansion before meter	20D	5D
Partially open valve	25D	5D

Velocity range

Maximum velocity, liquid: 30 feet/sec (9 meters/second)
 Minimum velocity, liquid: 1 foot/sec (.3 meters/second)
 Maximum velocity, gas or steam: 300 feet/sec (90 meters/second)
 Minimum velocity, gas or steam feet/sec (meters/second):

$$\frac{5}{\sqrt{\text{density (lb/ft}^3)}} \qquad \frac{6.1}{\sqrt{\text{density (kg/m}^3)}}$$

Consult the PanaFlow MV sizing program for easy calculation of flow range.

Water minimum and maximum flow rates						
Rate	Nominal pipe size (in)					
	3	6	8	12	16	24
GPM min	20.6	81.3	142	317	501	1138
GPM max	618	2437	4270	9501	15043	34144
Nominal pipe size (mm)						
	80	150	200	300	400	600
M3/hr min	5.2	20.4	35.4	79.2	125	284
M3/hr max	157	614	1062	2337	3753	8537

Typical saturated steam minimum and maximum flow rates (lb/hr)						
Pressure	Nominal Pipe Size (in)					
	3	6	8	12	16	24
5 psig	205 2721	800 10633	1385 18412	3099 41196	4893 65039	11132 147954
100 psig	468 14246	1831 55674	3170 96407	7092 215703	11197 340546	25472 774698
200 psig	632 25948	2471 101405	4278 175595	9572 392880	15111 620268	34377 1411029
300 psig	762 37652	2976 147145	5153 254799	11530 570093	18203 900047	41410 2047489
400 psig	873 49494	3412 193420	5908 334930	13219 749382	20870 1183103	47477 2691404
500 psig	974 61543	3805 240507	6588 416468	14741 931816	23272 1471125	52942 3346615

Typical saturated steam minimum and maximum flow rates (kg/hr)						
Pressure	Nominal Pipe Size (mm)					
	80	150	200	300	400	600
0 barg	81 938	316 3667	548 6350	1226 14209	1936 22432	4404 51039
5 barg	187 4946	729 19486	1263 33742	2826 75495	4461 119189	10151 271187
10 barg	249 8859	972 34620	1683 59949	3767 134132	5947 211764	13530 481821
15 barg	298 12700	1164 49629	2016 85939	4510 192283	7120 303570	16200 690705
20 barg	340 16550	1329 64676	2301 111995	5148 250581	8128 395609	18493 900119
30 barg	413 24357	1612 95187	2791 164827	6246 368789	9860 582234	22435 582234

Typical air minimum and maximum flow rates (SCFM) air at 70°F

Nominal pipe size (in)						
Pressure	3	6	8	12	16	24
0 psig	56 924	220 3611	381 6253	852 13991	1345 22089	3059 50250
100 psig	157 7236	615 28279	1065 48969	2383 109564	3763 172977	8560 393500
200 psig	216 13588	843 53101	1460 91950	3266 205732	5156 324804	11729 738886
300 psig	262 19974	1022 78059	1770 135169	3960 302430	6251 477467	14221 1086176
400 psig	301 26391	1175 103136	2034 178593	4551 399588	7186 630859	16346 1435121
500 psig	335 32834	1310 128314	2269 222191	5077 497136	8015 784865	18233 1785464

Typical air minimum and maximum flow rates (nm³/hr) air at 20°C

Nominal Pipe Size (mm)						
Pressure	80	150	200	300	400	600
0 barg	89 1463	347 5716	601 9897	1345 22145	2124 34962	4833 79547
5 barg	217 8702	847 34006	1467 58885	3282 131751	5181 208004	11788 473266
10 barg	294 15975	1148 62430	1987 108105	4446 241878	7020 381870	15972 868857
15 barg	355 23280	1385 90979	2399 157542	5368 352487	8474 556497	19282 1266182
20 barg	407 30615	1589 119642	2751 207175	6156 463539	9718 731823	22112 1665095
30 barg	495 45361	1934 177268	3349 306961	7493 686081	11829 1084302	26915 2467081

Approximate weight, lb (kg)

	CL	SL	EL
CNPT	13 (5.7)	14 (6.2)	15 (6.7)
C150	15 (6.8)	16 (7.3)	17 (7.8)
C300	17 (7.8)	18 (8.3)	19 (8.8)
C600	18 (8.2)	19 (8.0)	20 (9.2)

Add 11 lb (5 kg) for remote electronics

PanaFlow MV82-V, VT

in (mm)	CL/ Compact Length		SL/ Standard Length		EL/ Extended Length	
	A	B	A	B	A	B
CNPT, compression fitting, male NPT	21.6 (549)	9.8 (249)	38 (965)	26.2 (665)	50 (1270)	38.2 (970)
C150, compression fitting, 150 lb flange	21.6 (549)	10.9 (277)	38 (965)	27.3 (693)	50 (1270)	39.3 (998)
C300, compression fitting, 300 lb flange	21.6 (549)	10.8 (277)	38 (965)	27.2 (691)	50 (1270)	39.2 (996)
C600, compression fitting, 600 lb flange	21.6 (549)	10.4 (264)	38 (965)	26.8 (681)	50 (1270)	38.8 (986)

PanaFlow MV82-VTP

in (mm)	CL/ Compact Length		SL/ Standard Length		EL/ Extended Length	
	A	B	A	B	A	B
CNPT, compression fitting, male NPT	24.6 (625)	9.8 (249)	41 (1041)	26.2 (665)	53 (1346)	38.2 (970)
C150, compression fitting, 150 lb flange	24.6 (625)	10.9 (277)	41 (1041)	27.3 (693)	53 (1346)	39.3 (998)
C300, compression fitting, 300 lb flange	24.6 (625)	10.8 (274)	41 (1041)	27.2 (691)	53 (1346)	39.2 (996)
C600, compression fitting, 600 lb flange	24.6 (625)	10.4 (264)	41 (1041)	26.8 (681)	53 (1346)	38.8 (986)

Turndown

Turndown is application-dependent. Consult the PanaFlow MV sizing program for exact values. Turndown can exceed 100:1.

Dimensional outline: compression fitting models

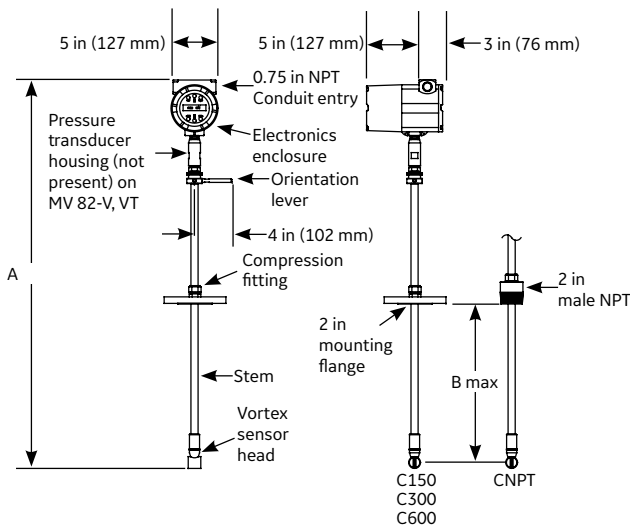

Dimensional outline: packing gland models

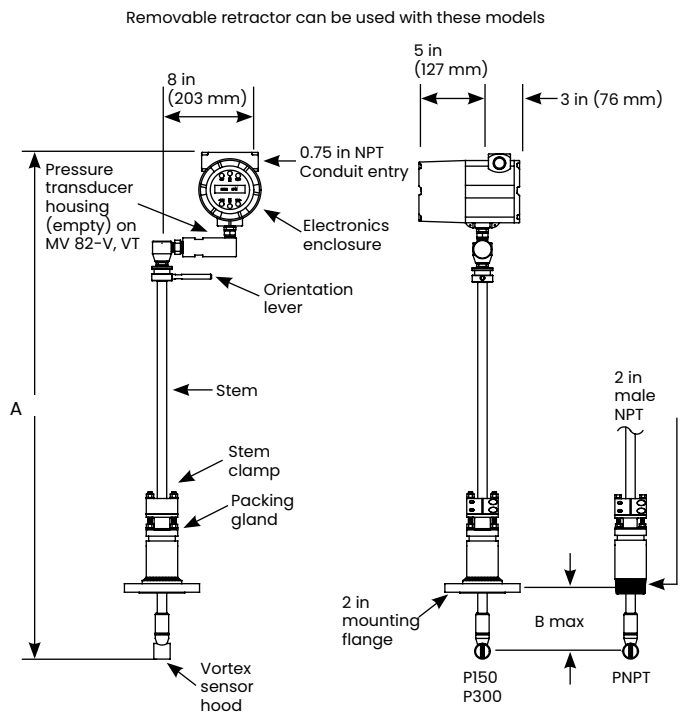

PanaFlow MV82 in (mm)	SL/Compact Length		EL/Standard Length	
	A	B	A	B
PNPT, packing gland, male NPTT	40.5 (1029)	21.5 (546)	52.5 (1334)	33.5 (851)
P150, packing gland, 150 lb flange	40.5 (1029)	21.1 (536)	52.5 (1334)	33.1 (841)
P300, packing gland, 300 lb flange	40.5 (1029)	21.1 (536)	52.5 (1334)	33.1 (841)

	Approximate weight, lb (kg)	
	SL	EL
PNPT	16 (7.1)	17 (7.6)
P150	21 (9.4)	22 (9.9)
P300	25 (11.3)	26 (11.8)

Add 11 lb (5 kg) for remote electronics

Dimensional outline: packing gland models with permanent retractor

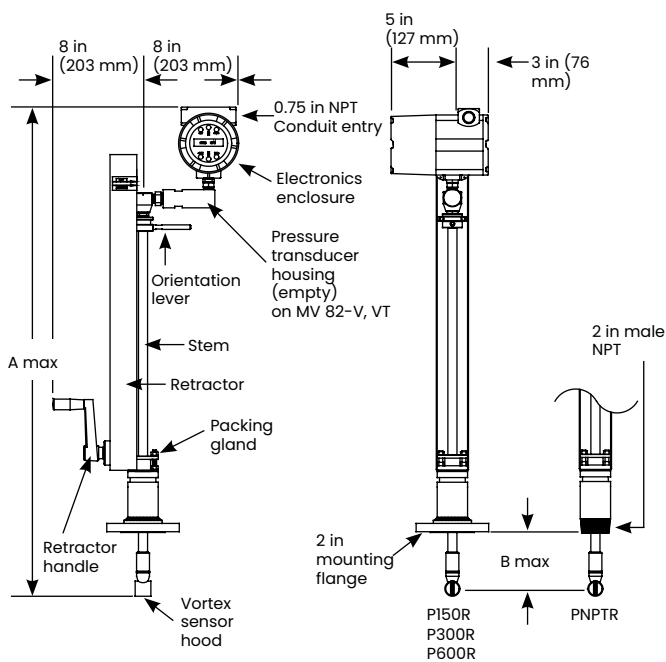

Dimensional outline: remote electronics option

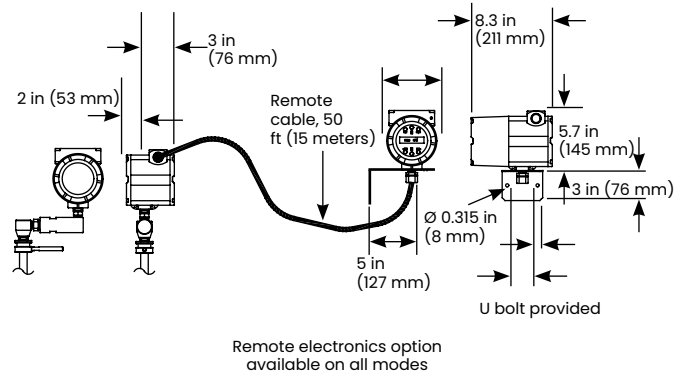

PanaFlow MV82 in (mm) with permanent retractor	SL/Standard Length		EL/Extended Length	
	A	B	A	B
PNPT, packing gland, male NPT	40.5 (1029)	21.5 (546)	52.5 (1334)	33.5 (851)
P150R, packing gland, 150 lb flange	40.5 (1029)	21.1 (536)	52.5 (1334)	33.5 (841)
P300R, packing gland, 300 lb flange	40.5 (1029)	21.1 (536)	52.5 (1334)	33.1 (841)
P600R, packing gland, 600 lb flange	40.5 (1029)	21.1 (536)	52.5 (1334)	33.1 (841)

	Approximate weight, lb (kg)	
	SL	EL
PNPT	25 (11.5)	32 (14.5)
P150	30 (13.7)	37 (16.7)
P300	34 (15.5)	41 (18.5)
P600	35 (16.0)	42 (19.0)

Add 11 lb (5 kg) for remote electronics

PanaFlow MV82 ordering information

Parent number code

MV82 Insertion multivariable mass
Vortex flowmeter

Feature 1: Multivariable options

V Volumetric flowmeter for liquid, gas and steam
VT Velocity and temperature sensors
VTP Velocity, temperature and pressure sensors
VT-EM Energy output options
VTP-EM Energy options with pressure sensor
VT-EP Velocity and temperature sensors with analog input for pressure
VTEP-EM Energy option with external pressure sensor

Feature 2: Probe length

SL Standard length
CL Compact length
EL Extended length

Feature 3: Electronics enclosure

L Local electronics Type 4X enclosure mounted on probe
R (25) Remote electronics Type 4X, 25 ft (8 m) cable
R (50) Remote electronics Type 4X, 50 ft (17 m) cable

Feature 4: Display options

DD Digital display and programming buttons
ND No display

Feature 5: Input power

DC2 12 to 36 VDC required on 2-wire (loop powered) meters with 1AHL only
DC4 12 to 36 VDC standard volumetric meter on 4-wire
AC 100-240 VAC, 50/60 Hz
DC4POE 12-28 VDC or Power over Ethernet (5 Watts maximum), Requires TCP/IP option

Feature 6: Output signal

1AHL Loop powered option - one analog output (4-20mA), one pulse, one frequency, HART (DC2 option only)
1AH One analog output (4-20mA), one alarm, one pulse, one frequency, HART (DC4 or AC option only)
1AM One analog output (4-20mA), one alarm, one pulse, one frequency, Modbus/RTU (DC4 or AC option only)
1AMIP One analog output (4-20mA), one alarm, one pulse, one frequency, Modbus TCP/IP (DC4POE option only)
1AB One analog output (4-20mA), one alarm, one pulse, one frequency, BACnet/MSTP (DC4 or AC option only)
1ABIP One analog output (4-20mA), one alarm, one pulse, one frequency, BACnet TCP/IP (DC4POE option only)
3AH Three analog output (4-20mA), three alarm, one pulse, one frequency, Modbus RTU (DC4 or AC option only)
3AM Three analog outputs (4-20 mA), three alarms, one pulse, MODBUS, (VT, VTP only)
3AMIP Three analog output (4-20mA), three alarms, one pulse, one frequency, Modbus TCP/IP (DC4POE option only)
3AB Three analog output (4-20mA), three alarm, one pulse, one frequency, BACnet/MSTP (DC4 or AC option only)
3ABIP Three analog output (4-20mA), three alarms, one pulse, one frequency, BACnet TCP/IP (DC4POE option only)

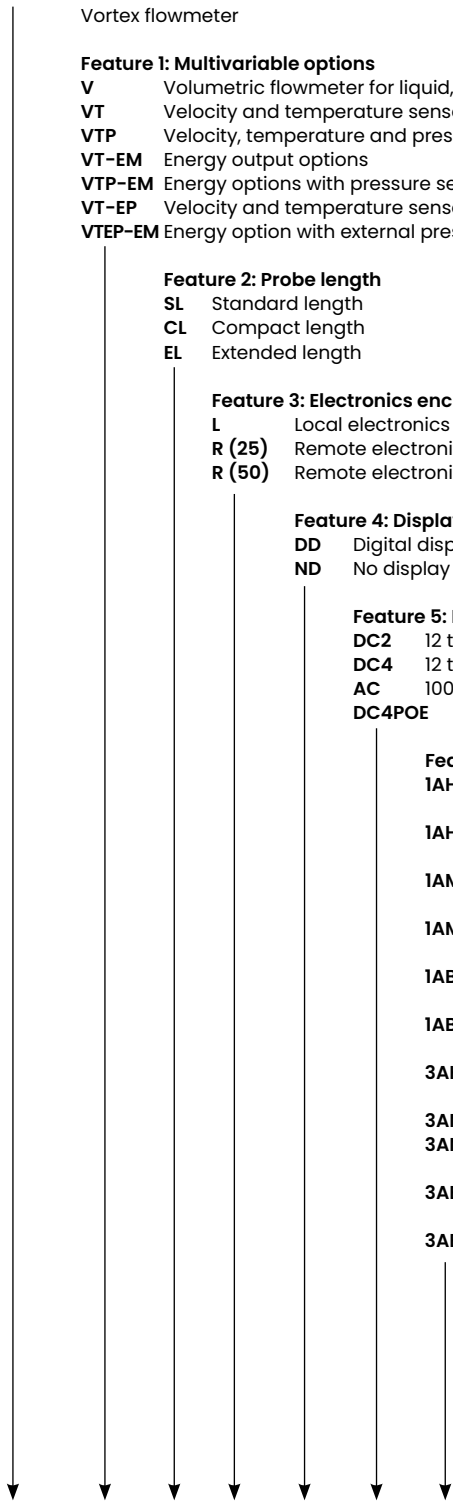

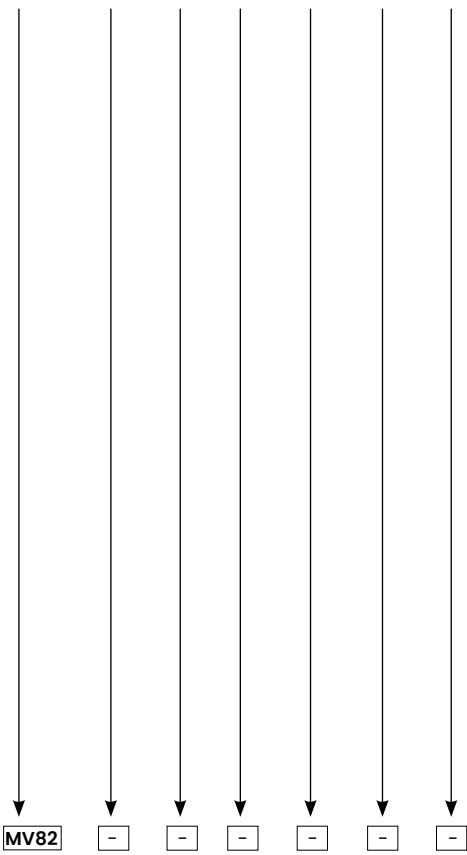

Feature 7: Process temperature options

- ST** Standard process temperature -40° to 500°F (-40° to 260°C)
- HT** High process temperature 750°F (400°C)

Feature 8: Pressure options

- P0** No pressure sensor
- P1** Maximum 30 psi (2 barg), Proof 60 psia (4barag)
- P2** Maximum 100 psi (7 barg), Proof 200 psia (14barag)
- P3** Maximum 300 psi (20 barg), Proof 600 psia (41 barag)
- P4** Maximum 500 psi (34 barg), Proof 1000 psia (64 barag)
- P5** Maximum 1500 psi (100 barg), Proof 2500 psia (175 barag)

Feature 9: Process connections

- | | |
|---|---|
| CNPT Compression, 2 inch NPT | P40 Packing gland, DN50 PN40 flange |
| C150 Compression, 2 inch 150# flange | PNPTR Packing gland, 2 inch NPT, retractor |
| C16 Compression, DN50 PN16 flange | P150R Packing gland, 2 inch 150# flange, retractor |
| C300 Compression, 2 inch 300# flange | P16R Packing gland, DN50 PN16 flange, retractor |
| C40 Compression, DN50 PN40 flange | P300R Packing gland, 2 inch 300# flange, retractor |
| C600 Compression, 2 inch 600# flange | P40R Packing gland, DN50 PN40 flange, retractor |
| C64 Compression, DN50 PN64 flange | P600R Packing gland, 2 inch 600# flange, retractor |
| PNPT Packing gland, 2 inch NPT | P64R Packing gland, DN50 PN64 flange, retractor |
| P150 Packing gland, 2 inch 150# flange | |
| P16 Packing gland, DN50 PN16 flange | |
| P300 Packing gland, 2 inch 300# flange | |

MV82

-

-

-

-

-

-

-

-

-

-

Panametrics, a Baker Hughes Business, provides solutions in the toughest applications and environments for moisture, oxygen, liquid and gas flow measurement. Experts in flare management, Panametrics technology also reduces flare emissions and optimizes performance.

With a reach that extends across the globe, Panametrics' critical measurement solutions and flare emissions management are enabling customers to drive efficiency and achieve carbon reduction targets across critical industries including: Oil & Gas; Energy; Healthcare; Water and Wastewater; Chemical Processing; Food & Beverage and many others.

Join the conversation and follow us on LinkedIn
[linkedin.com/company/panametricscompany](https://www.linkedin.com/company/panametricscompany)