



CSA Hazardous Area Approvals Fisher™ FIELDVUE™ DVC6200 Series Digital Valve Controllers

Hazardous Area Approvals and Special Instructions for “Safe Use” and Installations in Hazardous Locations

Certain nameplates may carry more than one approval, and each approval may have unique installation/wiring requirements and/or conditions of “safe use”. These special instructions for “safe use” are in addition to, and may override, the standard installation procedures. Special instructions are listed by approval type.

Note

This information supplements the nameplate markings affixed to the product and the DVC6200 Series quick start guide ([D103556X012](#)), available from your Emerson sales office or Local Business Partner, or at [Fisher.com](#).

Always refer to the nameplate itself to identify the appropriate certification.

⚠ WARNING

Failure to follow these conditions of “safe use” could result in personal injury or property damage from fire or explosion and area re-classification.

Ordinary Locations Approval

Complies with general electrical safety CAN/CSA-C22.2 No. 61010-1-2004
SELV, conduit connected, Enclosure Type 4X, IP66, Installation Category I, Pollution Degree 4

DVC6200 Series (HART HW1, FOUNDATION Fieldbus, PROFIBUS)

Rated Input 9-30 VDC, 4-20 mA
-52°C to + 80°C Ambient

DVC6205 (HART HW1, FOUNDATION fieldbus, PROFIBUS)

Rated Input 9-30 VDC, 4-20 mA
Outputs 0-9.6 VDC, 0-3.5 mA
-52°C to + 80°C Ambient

DVC6215 Remote Mount

Rated Input 10 VDC max, 3.5 mA max
-52 to 125°C Ambient

Explosion-proof and Dust Ignition-proof

DVC6200 and DVC6205 Series (HART HW1 & HW2, SIS, FOUNDATION Fieldbus, PROFIBUS)

Class I, Division 1, Groups B,C,D ; Class I, Division 2, Groups A,B,C,D

Class II, Division 1, Groups E,F,G ; Class II, Division 2, Groups F,G

Class III, Division 1

Ex d IIC

Ex nC IIC

Type 4X, IP66

Single Seal Device (HART HW2 and SIS pending)

Rated input 30 Vmax, 20 mA

- 52°C < Ambient < + 80°C

Max inlet pressure 10 bar (145 psig) (air or natural gas)

Temperature Code: T6 (Tamb ≤ 75°C), T5 (Tamb ≤ 80°C)

DVC6215 Remote Mount

Class I, Division 1, Groups A,B,C,D ; Class I, Division 2, Groups A,B,C,D

Class II, Division 1, Groups E,F,G ; Class II, Division 2, Groups F,G

Class III, Division 1

Ex d IIC

Ex nA IIC

Type 4X, IP66

Rated input 30 Vmax, 20 mA

- 52°C < Ambient < + 125°C

Temperature Code: T6 (Tamb ≤ 75°C), T5 (Tamb ≤ 90°C), T4 (Tamb ≤ 125°C)

Intrinsically Safe

Class I, Division 1, Groups A,B,C,D

Class II, Division 1, Groups E,F,G

Class III, Division 1

Ex ia IIC

Type 4X, IP66

Single Seal Device (HART HW2 and SIS pending)

Rated input 30 V DC max, 20 mA

- 52°C < Ambient < + 80°C (-52°C to 125°C for DVC6215)

Max inlet pressure 10 bar (145 psig) (air or natural gas)

Intrinsically safe when connected per installation drawing GE42818, as shown in the following figures

DVC6200 HW2 and DVC6200 SIS figure 1 and 6

DVC6205, DVC6205 SIS, and DVC6215 Remote Mount figure 2 and 6

DVC6200f and DVC6200p figure 3 and 6

DVC6205f, DVC6205p, and DVC6215 Remote Mount figure 4 and 6

DVC6200 HW1 figure 5 and 6

Figure 1. CSA Loop Schematics—FIELDVUE DVC6200 HW2 and DVC6200 SIS

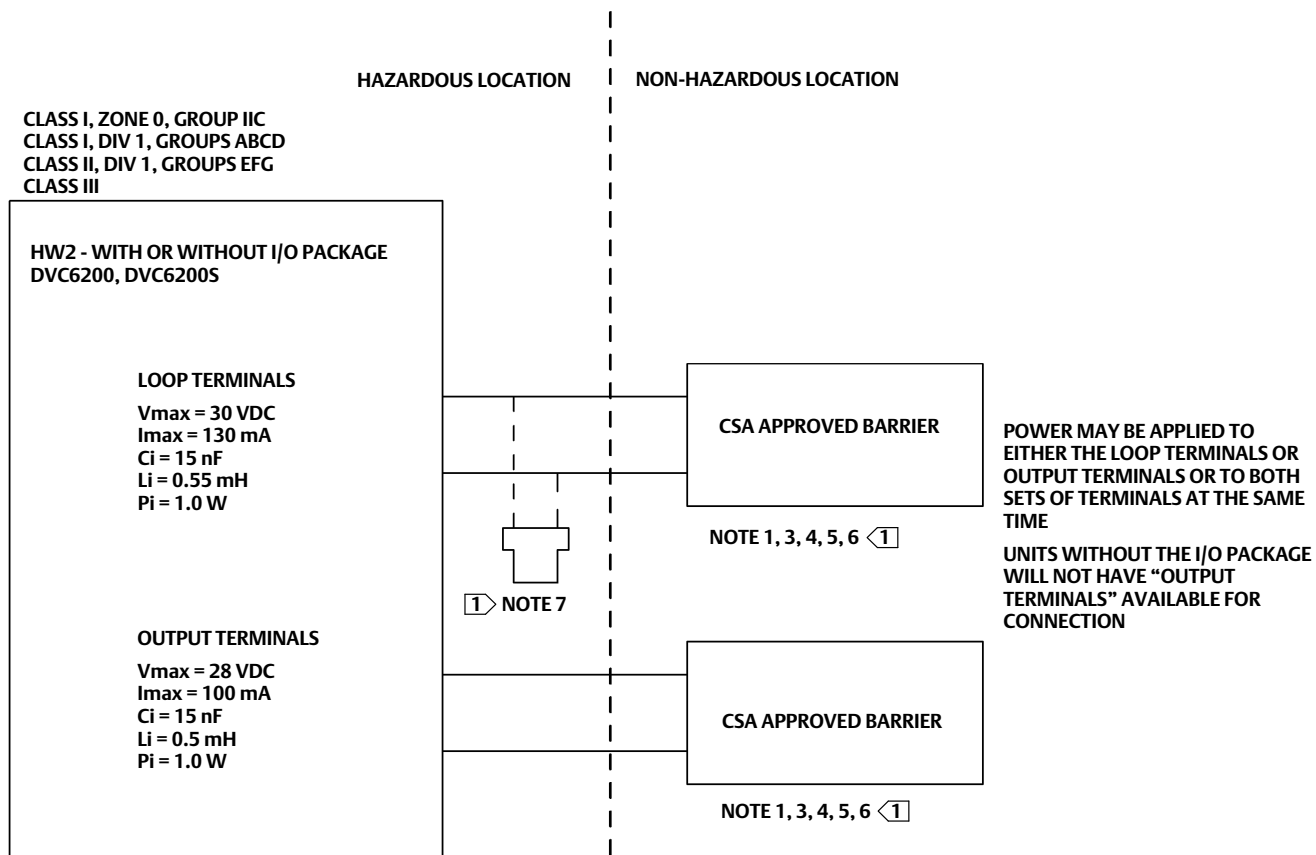

T CODE	WITH I/O PACKAGE	WITHOUT I/O PACKAGE
	T (amb)	T (amb)
T5	$\leq 80^\circ\text{C}$	$\leq 80^\circ\text{C}$
T6	$\leq 61^\circ\text{C}$	$\leq 74^\circ\text{C}$

GE42818 Sheet 11, Rev. C

1 SEE NOTES IN FIGURE 6

Figure 2. CSA Loop Schematics—FIELDVUE DVC6205, DVC6205 SIS, and DVC6215

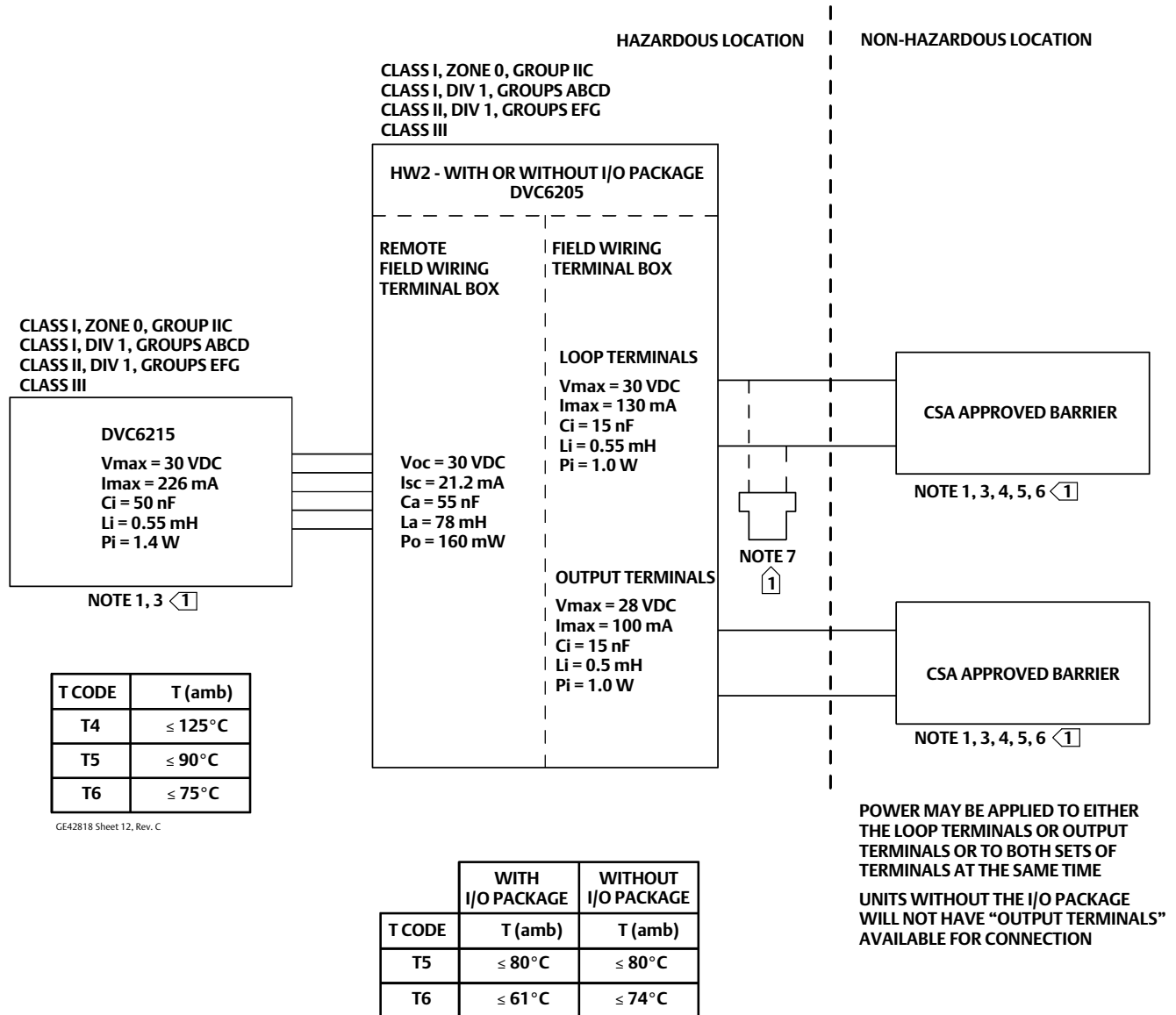

1 SEE NOTES IN FIGURE 6

Figure 3. CSA Loop Schematics—FIELDVUE DVC6200f and DVC6200p

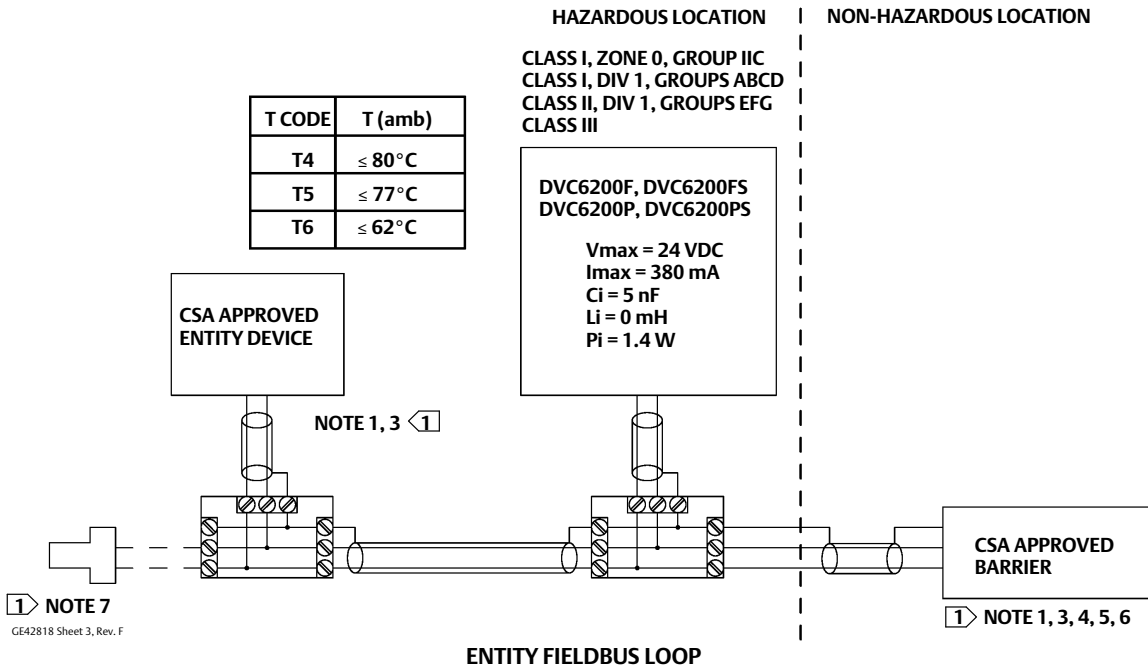

SEE NOTES IN FIGURE 6

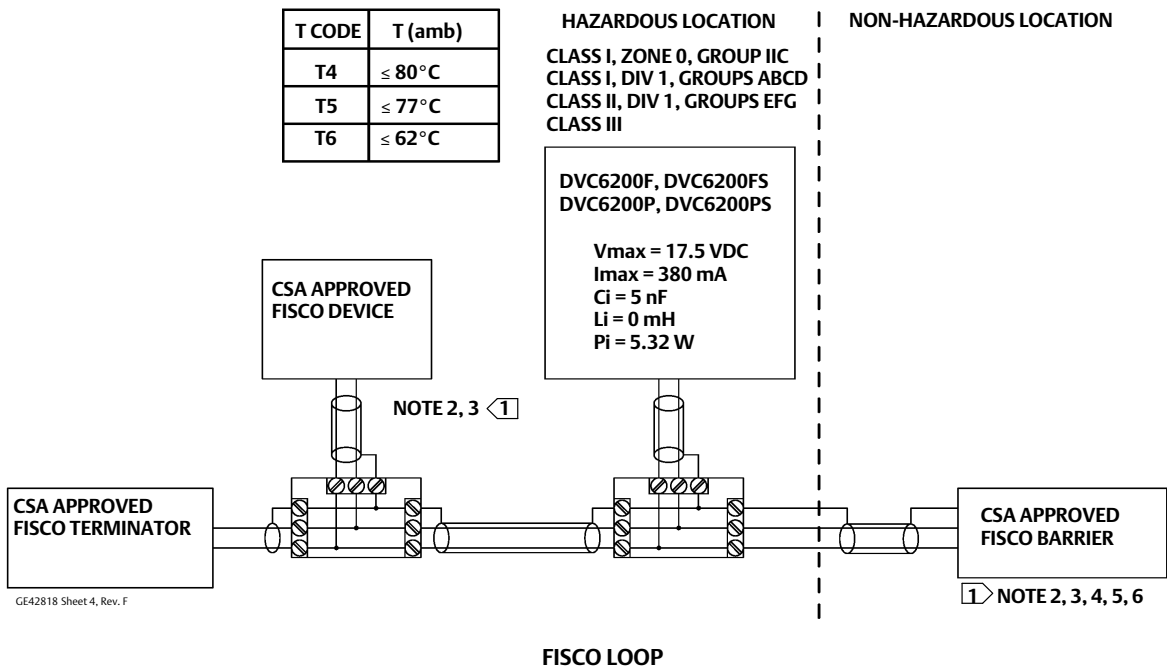

SEE NOTES IN FIGURE 6

Figure 4. CSA Loop Schematics—FIELDVUE DVC6205f, DVC6205p, and DVC6215

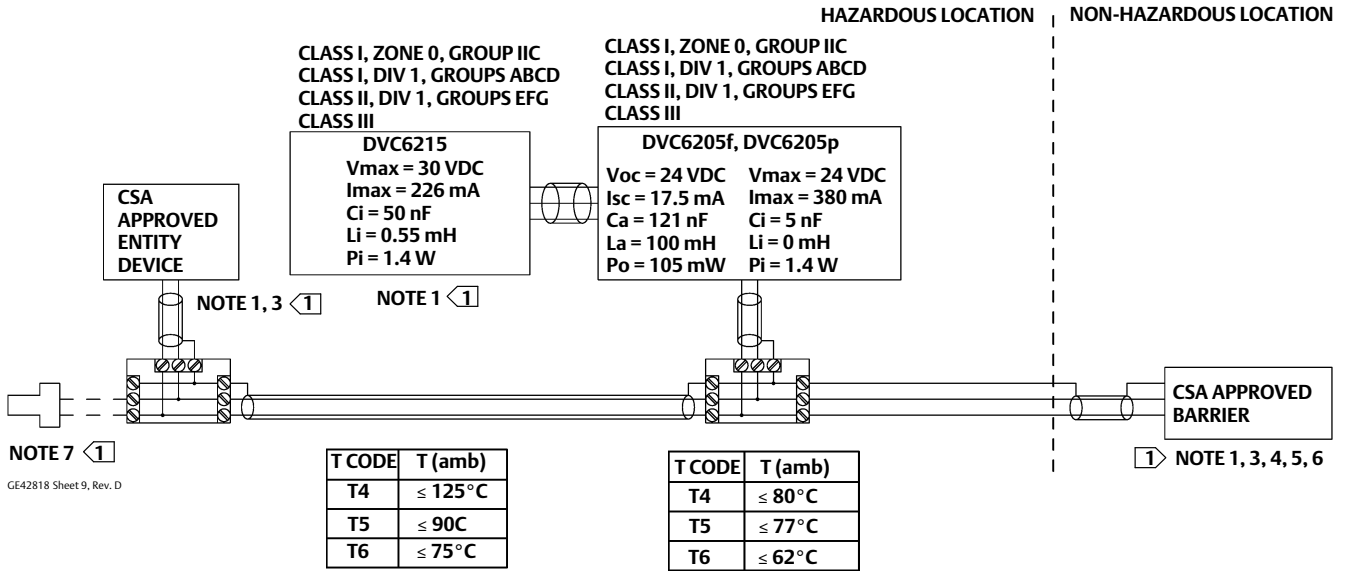

ENTITY FIELDBUS LOOP

1 SEE NOTES IN FIGURE 6

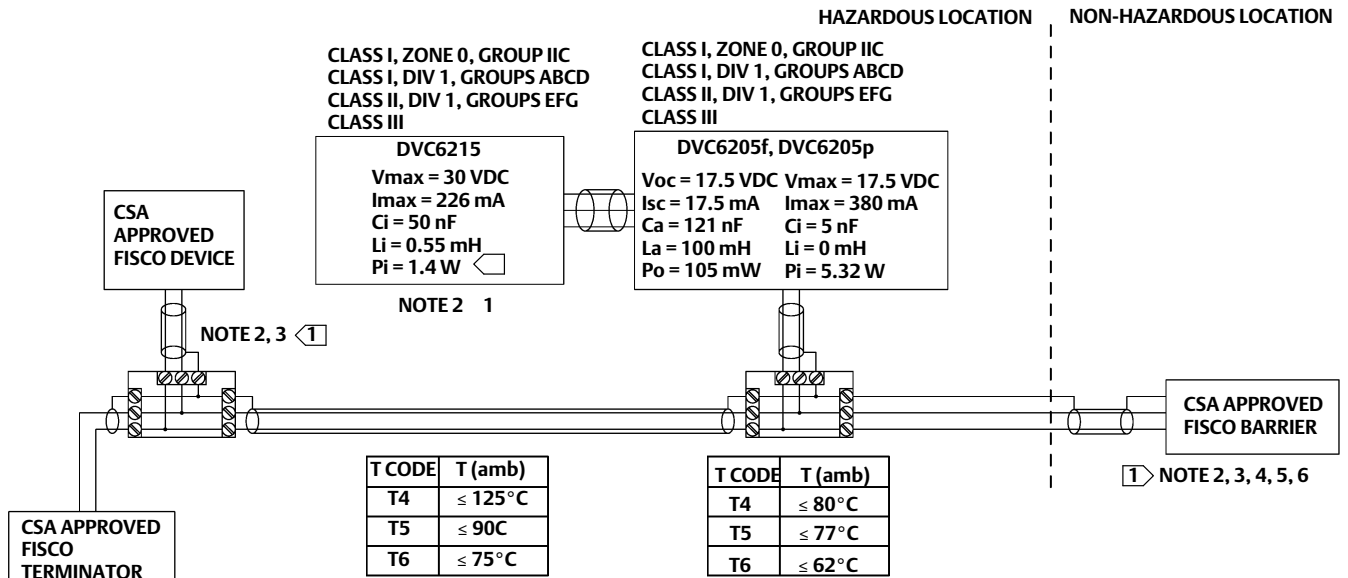

FISCO LOOP

1 SEE NOTES IN FIGURE 6

Figure 5. CSA Loop Schematic—FIELDVUE DVC6200 HW1

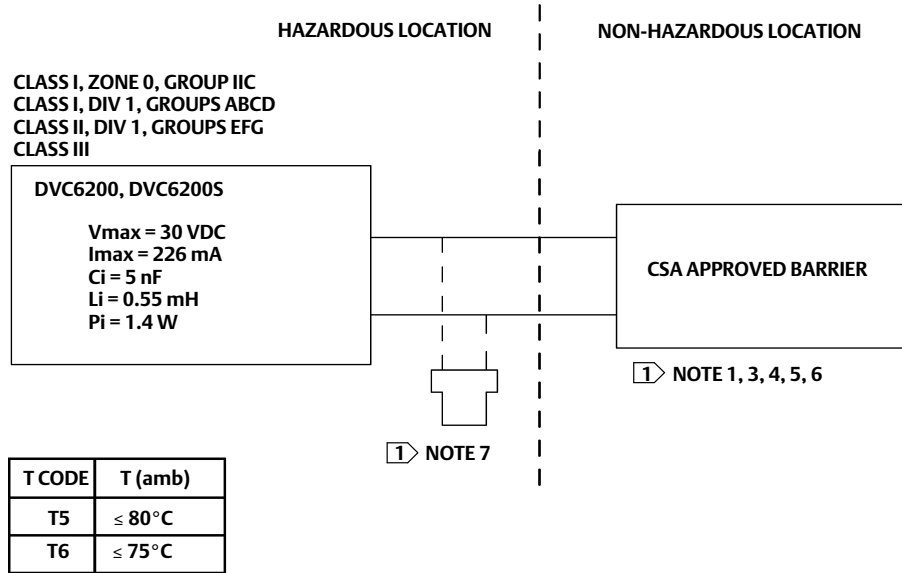

GE42818 sheet 2, Rev. F

SEE NOTES IN FIGURE 6

Figure 6. Notes for CSA Loop Schematics

1 THE ENTITY CONCEPT ALLOWS INTERCONNECTION OF INTRINSICALLY SAFE APPARATUS TO ASSOCIATED APPARATUS NOT SPECIFICALLY EXAMINED IN SUCH COMBINATION. THE CRITERIA FOR INTERCONNECTION IS THAT THE VOLTAGE (V_{max} or U_i), THE CURRENT (I_{max} or I_i), AND THE POWER (P_{max} or P_i) OF THE INTRINSICALLY SAFE APPARATUS MUST BE EQUAL TO OR GREATER THAN THE VOLTAGE (V_{oc} or U_o), AND THE CURRENT (I_{sc} or I_o), AND THE POWER (P_o) DEFINED BY THE ASSOCIATED APPARATUS. IN ADDITION, THE SUM OF THE MAX UNPROTECTED CAPACITANCE (C_i) AND MAX UNPROTECTED INDUCTANCE (L_i), INCLUDING THE INTERCONNECTING CABLING CAPACITANCE (C_{cable}) AND CABLING INDUCTANCE (L_{cable}) MUST BE LESS THAN THE ALLOWABLE CAPACITANCE (C_a) AND INDUCTANCE (L_a) DEFINED BY THE ASSOCIATED APPARATUS. IF THE ABOVE CRITERIA IS MET, THEN THE COMBINATION MAY BE CONNECTED.

$$V_{max} \text{ or } U_i \geq V_{oc} \text{ or } U_o \quad I_{max} \text{ or } I_i \geq I_{sc} \text{ or } I_o \quad P_{max} \text{ or } P_i \geq P_o \quad C_i + C_{cable} \leq C_a \quad L_i + L_{cable} \leq L_a$$

2 THE FISCO CONCEPT ALLOWS INTERCONNECTION OF INTRINSICALLY SAFE APPARATUS TO ASSOCIATED APPARATUS NOT SPECIFICALLY EXAMINED IN SUCH COMBINATION. THE CRITERIA FOR THE INTERCONNECTION IS THAT THE VOLTAGE (V_{max} or U_i), CURRENT (I_{max} or I_i), AND POWER (P_{max} or P_i), WHICH AN INTRINSICALLY SAFE APPARATUS CAN RECEIVE AND REMAIN INTRINSICALLY SAFE, CONSIDERING FAULTS, MUST BE EQUAL TO OR GREATER THAN THE VOLTAGE (V_{oc} or U_o), CURRENT (I_{sc} or I_o), AND POWER (P_o) LEVELS WHICH CAN BE DELIVERED BY THE ASSOCIATED APPARATUS, CONSIDERING FAULTS AND APPLICABLE FACTORS. IN ADDITION THE MAXIMUM UNPROTECTED CAPACITANCE (C_i) AND INDUCTANCE (L_i) OF EACH APPARATUS (OTHER THAN THE TERMINATION) CONNECTED TO THE FIELD BUS MUST BE LESS THAN OR EQUAL TO 5 nF AND 10 μH RESPECTIVELY.

IN EACH SEGMENT ONLY ONE ACTIVE DEVICE, NORMALLY THE ASSOCIATED APPARATUS, IS ALLOWED TO PROVIDE THE NECESSARY ENERGY FOR THE FIELD BUS SYSTEM. THE VOLTAGE (U_o or V_{oc} or V_t) OF THE ASSOCIATED APPARATUS HAS TO BE LIMITED TO THE RANGE OF 9 V TO 17.5 VDC. ALL OTHER EQUIPMENT CONNECTED TO THE BUS CABLE HAS TO BE PASSIVE, MEANING THAT THEY ARE NOT ALLOWED TO PROVIDE ENERGY TO THE SYSTEM, EXCEPT FOR A LEAKAGE CURRENT OF 50 μA FOR EACH CONNECTED DEVICE. SEPARATELY POWERED EQUIPMENT NEEDS A GALVANIC ISOLATION TO ASSURE THAT THE INTRINSICALLY SAFE FIELD BUS CIRCUIT REMAINS PASSIVE.

CONTINUED ON NEXT PAGE...

Figure 6. Notes for CSA Loop Schematics (continued)

2 CONTINUED

THE CABLE USED TO CONNECT THE DEVICES NEEDS TO HAVE THE PARAMETERS IN THE FOLLOWING RANGE:

LOOP RESISTANCE R': 15 TO 150 ohms/km

INDUCTANCE PER UNIT LENGTH L: 0.4 TO 1 mH/km

CAPACITANCE PER UNIT LENGTH C': 80 TO 200 nF/km

C' = C' LINE/LINE + 0.5' LINE/SCREEN, IF BOTH LINES ARE FLOATING OR

C' = C' LINE/LINE + C' LINE/SCREEN, IF THE SCREEN IS CONNECTED TO ONE LINE.

LENGTH OF SPLICE: < 1 m (T-BOX MUST ONLY CONTAIN TERMINAL CONNECTIONS WITH NO ENERGY STORAGE CAPABILITY)

LENGTH OF SPUR CABLE: < 30 M

LENGTH OF TRUNK CABLE: < 1 km

AT EACH END OF THE TRUNK CABLE AN APPROVED INFALLIBLE TERMINATION WITH THE FOLLOWING PARAMETERS IS SUITABLE:

R = 90 TO 100 ohms AND C = 0 TO 2.2 uF

NOTE, A BUILT-IN TERMINATOR IS INCLUDED IN THE FIELD SIDE AND A SELECTABLE TERMINATOR IS AVAILABLE ON THE HOST SIDE.

THE NUMBER OF PASSIVE DEVICES CONNECTED TO THE BUS SEGMENT IS NOT LIMITED IN THE FISCO CONCEPT FOR INTRINSICALLY SAFE REASONS. IF THE ABOVE RULES ARE RESPECTED, UP TO A TOTAL LENGTH OF 1000 m (SUM OF THE LENGTH OF THE TRUNK CABLE AND ALL SPUR CABLES), THE INDUCTANCE AND CAPACITANCE OF THE CABLE WILL NOT IMPAIR THE INTRINSIC SAFETY OF THE INSTALLATION.

3 INSTALLATION MUST BE IN ACCORDANCE WITH THE CANADIAN ELECTRICAL CODE (CEC) AND ANSI/ISA RP12.6.

4 MAXIMUM SAFE AREA VOLTAGE SHOULD NOT EXCEED 250 Vrms.

5 RESISTANCE BETWEEN INTRINSICALLY SAFE GROUND AND EARTH GROUND MUST BE LESS THAN ONE OHM

6 LOOPS MUST BE CONNECTED ACCORDING TO THE BARRIER MANUFACTURER'S INSTRUCTIONS.

7 IF HAND-HELD COMMUNICATOR OR MULTIPLEXER IS USED, IT MUST BE CSA APPROVED WITH ENTITY PARAMETERS AND INSTALLED PER THE MANUFACTURER'S CONTROL DRAWINGS.

CE42818 Sheet 8, Rev. E

Neither Emerson, Emerson Automation Solutions, nor any of their affiliated entities assumes responsibility for the selection, use or maintenance of any product. Responsibility for proper selection, use, and maintenance of any product remains solely with the purchaser and end user.

Fisher and FIELDVUE are marks owned by one of the companies in the Emerson Automation Solutions business unit of Emerson Electric Co. Emerson Automation Solutions, Emerson, and the Emerson logo are trademarks and service marks of Emerson Electric Co. All other marks are the property of their respective owners.

The contents of this publication are presented for informational purposes only, and while every effort has been made to ensure their accuracy, they are not to be construed as warranties or guarantees, express or implied, regarding the products or services described herein or their use or applicability. All sales are governed by our terms and conditions, which are available upon request. We reserve the right to modify or improve the designs or specifications of such products at any time without notice.

Emerson Automation Solutions
Marshalltown, Iowa 50158 USA
Sorocaba, 18087 Brazil
Cernay, 68700 France
Dubai, United Arab Emirates
Singapore 128461 Singapore

www.Fisher.com



EMERSON[™]