



A new and improved approach to ammonia gas detection

EC-FX-NH3 Sensor & Transmitter

Introducing a better, tougher, longer-lasting sensor for industrial refrigeration

Three harsh environments. One tough sensor.

If you use ammonia as part of your refrigeration process, you face several challenges in protecting your plant from the danger and expense of ammonia leaks:



Cold Storage

From banana rooms to ice cream storage to food processing facilities, your cold storage areas are subject to extremely low temperatures — plus changes in humidity during cleaning and changes in pressure due to opening and closing doors. These fluctuations can cause some ammonia sensors to go into fault or false alarm. But since workers are often present in these areas, it's critical for ammonia sensors to stand up to tough conditions and accurately report gas at low levels.



Refrigerated Processing Areas

Some of the harshest environments in the food industry are spiral freezers and blast freezers, where rapid freezing often means drastic changes in temperature. This temperature shock — along with humidity shock from hot-water washdowns — can further challenge the resilience of your ammonia sensors.



Engine Rooms

Finally, the most likely places for a catastrophic ammonia leak are often your engine rooms, since they typically hold ammonia for use throughout your plant. But in the hot conditions of most engine rooms, the liquid electrolytes in standard ammonia sensor cells can dry out quickly, sometimes reducing the sensor's life span and causing false alarms.

*Maintaining sensitivity and accuracy —
even with rapid changes in temperature
and humidity*



Breakthrough technology, only from Honeywell Analytics.

In response to these challenging conditions, Honeywell Analytics has developed an innovative new ammonia detector — delivering reliability, accuracy and long-lasting performance that you can't get anywhere else.

The EC-FX-NH3, an evolution of our Manning EC-F9-NH3, features an all-new ammonia sensor with a proprietary electrolyte that stands up to harsh environments.

So whether you're monitoring ammonia in blast freezers, cold storage or engine rooms, you can feel confident in the effectiveness of your gas detection system, helping you ensure life safety, prevent food spoilage and manage costs.

Proprietary technology for longer life and lower costs



EC-FX-NH3 with Stainless Steel enclosure and LCD options

Double the warranty

We stand behind our products. We are so confident in the performance of our new sensor that it comes with a two-year warranty — ***twice the warranty of most competing sensors.***



The next generation in ammonia sensors

Our proprietary new sensor in the EC-FX-NH₃, backed by rigorous testing, was engineered to Honeywell's highest standards of safety, reliability and cost-effectiveness:

Stability you can count on.

Unlike other ammonia sensors, our new sensor maintains sensitivity — even during rapid changes in temperature and humidity. While other sensors may quickly lose sensitivity after exposure to ammonia gas, our EC-FX sensor bounces back from alarm-level gas exposure and resumes accurate detection. So you can rest assured that your ammonia sensors are protecting lives and operations.

Lower cost of ownership.

Fewer sensor replacements means a lower cost of ownership over time. In fact, if you're currently using our EC-F9 or EC-F2 transmitter, you can significantly cut your costs by switching out your current sensor for the new EC-FX sensor. Over a 10-year period, you can save up to \$2,500 per sensor in the engine room and up to \$1,300 per sensor in cold storage and blast freezers.

Longer life span.

Thanks to our proprietary technology, the EC-FX sensor lasts up to 18 months longer than competitors — and we back it up with the longest warranty on the market. See how it compares:

Application	Competing Sensors	EC-FX Sensor
Cold storage and freezers	Replace once or more every two years	Replace once every three to four years
Engine rooms	Replace every six to 18 months	Replace once every two to three years

And if you're using an ammonia gas detector from another manufacturer, you can potentially save even more by switching to the EC-FX-NH₃ transmitter with the all-new sensor. Over a 10-year period, you can cut costs by up to \$5,500 per sensor in the engine room and \$2,800 per sensor in cold storage and blast freezers.

Depending on the number of ammonia gas detectors in your operations, that longer sensor life can add up to serious savings.

How much can you save?

Call us at **1-800-444-9935** to discuss the long-term savings based on your equipment.

EC-FX-NH3 Sensor & Transmitter

The gold standard in ammonia detection — with innovation you can trust

The EC-FX-NH3 is the next evolution of the proven Manning Systems technology, which was designed specifically for the extreme conditions of fruit and vegetable processing, bakeries, meat and poultry processing, beverage and bottling plants, and more.

In fact, our Manning EC-F9 and EC-F2 products have been the most-installed ammonia gas detectors in the refrigeration industry. Now, with the all-new EC-FX-NH3 from Honeywell Analytics, we're making that great technology even better.

Robust capabilities with unique design

The EC-FX-NH3 responds quickly to ammonia gas concentrations in low parts per million (PPM). You can count on this detector to stand up to the challenges of industrial refrigeration environments.

- **Rugged construction for long-term reliability.** Unlike fragile plastic housings that may break in cold temperatures, the heavy-duty steel enclosure of the EC-FX-NH3 was built to withstand cold and wet environments. The EC-FX-NH3 is also available in stainless steel.
- **ATMOS™ Technology for environmental flexibility.** The EC-FX-NH3 automatically adapts to its environment and can operate in -50°F and 100 percent humidity. So whether you're monitoring ammonia in a banana room or a blast freezer, during dry conditions or a hot-water washdown, the detector maintains accurate and reliable performance.

*Creating a new standard
of reliability in ammonia
gas detection*

- **SensorCheck™ Technology for peace of mind.** The EC-FX-NH3 is equipped with a microprocessor that checks the electrical viability of the sensor every 24 hours. If there's a problem, SensorCheck sends an indication to your controller — so you can rest assured that the sensor is operating properly.
- **Optional LCD for real-time visibility.** With an easy-to-read display, you can clearly see the ammonia concentration at any given time. The optional display also makes it easy to set alarm levels and change settings — all from the detector.

Add it up, and our new EC-FX-NH3 gas detector — housing an all-new, proprietary ammonia sensor from Honeywell Analytics — is the new gold standard for reliability, accuracy and long-term performance in ammonia gas detection.

Isn't it time you upgraded to the most innovative, longest-lasting technology for ammonia detection?

Contact Honeywell Analytics today at **1-800-444-9935** to upgrade your ammonia sensors, reduce your costs, and ensure the continued safety and productivity of your plant.

EC-FX SPECIFICATIONS

Ammonia Gas Sensor

Measurement	
Operating Principle	3-electrode electrochemical
Measurement Range	0-100, 0-200, and 0-250PPM NH ₃
Maximum Overload	500 ppm
Lower Detection Limit	< 10 ppm
Filter	None
Sensitivity	100 ± 40 nA/ppm
Response Time (T90)	< 30 s
Baseline Offset (clean air)	< ±0.2 mA
Zero Shift (+10°C to +40°C)	< 4 ppm
Accuracy	± 5% full scale*
Repeatability	< 10% of full scale
Mechanical	
Housing Material	Polyphenylene Oxide (PPO) Noryl
Weight	4.5 g
Orientation	Vertical only
Environmental	
Typical Applications	Industrial refrigeration, cold storage, and rooms
Operating Temperature Range	Continuous: -4° to 122°F (sensor only) Storage: -58° to 122°F (sensor only)
Operating Pressure Range	Atmospheric ± 10%
Operating Humidity Range	5% to 95% RH non-condensing
Intrinsic Safety Data	
Maximum at 1000ppm	< 0.14 mA
Maximum o/c Voltage	< 1.2 V
Maximum s/c Current	< 100 mA
Lifetime	
Long Term Output Drift	< 5% per 6 months
Expected Operating Life	Cold Storage: 3-4 years in average conditions Engine Room: 2-3 years in average conditions
Storage Life	6 months in sealed container
Standard Warranty	Two years from date of shipment

* ±5% of full scale range at temperature of calibration. Contact HA for additional details.

CAUTION:

EC-FX is designed for operation in a wide range of environments and harsh conditions. However, it is important that exposure to high concentrations of solvent vapors is avoided, both during storage, fitting into instruments, and operation.

EC-FX is designed to be used in safety critical applications. To ensure that the sensor and/or instrument in which it is used, are operating properly, it is a requirement that the function of the device is confirmed by exposure to target gas (bump check). Failure to carry out such tests on a regular basis may jeopardize the safety of people and property.

PLEASE NOTE:

Connection should be made via PCB sockets only. Soldering to pins will render your warranty void.

While every effort has been made to ensure accuracy in this publication, no responsibility can be accepted for errors or omissions. Data may change, as well as legislation, and you are strongly advised to obtain copies of the most recently issued regulations, standards, and guidelines. This publication is not intended to form the basis of a contract.

Find out more

www.honeywellanalytics.com

Toll-free: 800.444.9935

SS01162_V2 5/14
© 2014 Honeywell Analytics

Product Dimensions

All dimension in mm, all tolerances ± 0.15 mm unless otherwise stated.

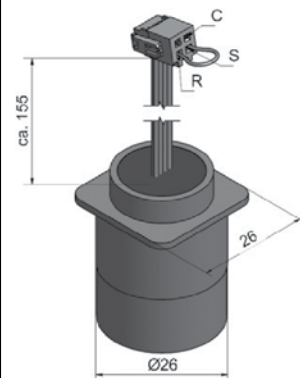

Cross-sensitivity Data

While Honeywell cells are designed to be highly specific to the gas they are intended to measure, they will still respond to some degree to certain gases. The table below is not exclusive and other gases not included in the table may still cause a sensor to react.

Gas	Concentration Used (ppm)	Reading (ppm)
Carbon Dioxide CO ₂	5000	0
Ethylene C ₂ H ₄	200	0
Carbon Monoxide CO	50	13
Hydrogen Sulfide H ₂ S	10	47
Sulfur Dioxide SO ₂	20	16
Iso-Propanol C ₃ H ₇ OH	11000	21
Hydrogen H ₂	3000	141
Methane CH ₄	18500	0
Ozone O ₃	0.25	-1
Chlorine Cl ₂	10	-20

The cross-sensitivity values quoted are based on tests conducted on a small number of sensors. They are intended to indicate sensor response to gases other than the target gas. Sensors may behave differently with changes in ambient conditions and may show some variation from the values quoted.

Honeywell Analytics Lines of Business



Commercial

Gas detection from standalone units to fully engineered, multi-point systems, all offering cost-effective regulatory compliance

- » Applications: parking structures, chillers, mechanical rooms, office towers, commercial buildings, shopping centers, swimming pools, golf courses, schools and universities, laboratories

Find out more

www.honeywellanalytics.com

Contact Honeywell Analytics:

USA

Honeywell Analytics, Inc.
405 Barclay Blvd.
Lincolnshire, IL 60069
USA

Toll-free: 1-800-444-9935

Fax: +1-888-967-9938

ha_manning@honeywell.com

USA Technical Services

Tel: 1-800-538-0363

haservice@honeywell.com

Canada

2840 2nd Ave SE
Calgary, Alberta, Canada
T2A 7X9

3580 Rue Isabelle Unit 100
Brossard, Quebec, Canada
J4Y 2R3

Toll-free: 1-800-563-2967 (select lang. + press 1)

Tel: 847-955-8200

Fax: +1-450-619-2448

hasales.canada@honeywell.com

Canada Technical Services

Tel: 1-800-538-0363

haservice.canada@honeywell.com

www.honeywell.com

Industrial

Renowned Sieger and Manning gas detection systems with advanced electrochemical, infrared and open path sensing technologies

- » Applications: oil and gas, cold storage, water/wastewater treatment, chemicals, engine rooms, plastics and fibers, agriculture, printing and light industrial



High Tech/Government

A complete portfolio of gas and chemical detection instrumentation including infrared spectroscopy (MST) with no cross interference, to Chemcassette paper-based solutions (MDA Scientific) offering detection down to parts per billion

- » Applications: semiconductor manufacturing and nanotechnology, aerospace propulsion and safety, specialty chemicals industry, research laboratories, emergency response

Europe, Middle East, Africa

Life Safety Distribution AG
Weiherallee 11a
CH-8610 Uster
Switzerland

Tel: +41 (0) 44 943 4300

Fax: +41 (0) 44 943 4398

gasdetection@honeywell.com

Portables

Single or multi-gas and other premium detectors with compact, lightweight designs ranging from simple alarm only units to advanced, fully configurable and serviceable instruments

- » Applications: underground utility and electricity ducts, boiler rooms, post-fire sites, sewers, industrial plants, industrial hygiene, first responder teams, remote fleets



Technical Services

24/7 global network includes post-sales service and Systems Integration teams

- » Emergency call out, service contracts, on/off-site repair, training and commissioning
- » Complete range of spares, consumables and accessories

Asia Pacific

Honeywell Analytics, Asia Pacific
#508, Kolon Science Valley (1)
187-10 Guro-Dong, Guro-Gu
Seoul, 152-050

Korea

Tel: +82 2 6909 0300

Fax: +82 2 2025 0328

analytics.ap@honeywell.com

Please Note:

While every effort has been made to ensure accuracy in this publication, no responsibility can be accepted for errors or omissions. Data may change, as well as legislation, and you are strongly advised to obtain copies of the most recently issued regulations, standards, and guidelines. This publication is not intended to form the basis of a contract.

H_EC-FX-NH3_BRO1162_V2 5/14
© 2014 Honeywell Analytics

Honeywell