

3500 Internal Barriers

Bently Nevada™ Asset Condition Monitoring

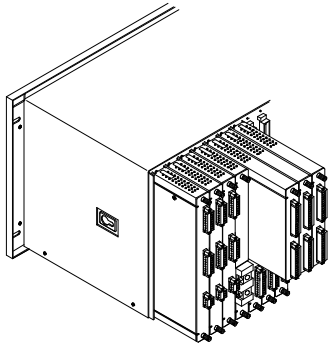

Description

3500 Internal Barriers are intrinsically safe interfaces that provide explosion protection for transducer systems connected directly to the 3500 Machinery Protection System.

The barrier designs are fully compatible with the 3500 System, and provide a convenient and cost-effective solution for installing all types of transducer systems within a hazardous area. Unlike external barriers, 3500 Internal Barriers are an integral part of the 3500 System and will not degrade the 3500 System's performance.

We can supply most Bently Nevada transducer systems that have comprehensive approvals for hazardous area installations and are matched to those of the 3500 Internal Barriers (consult Table 1 for compatible monitors and transducers). The design of each component complies both individually and as part of a system with the strict safety requirements of North American and International Standards. This removes the need for a system designer to reference individual certificates to verify the compatibility between components.

Standard and Internal Barrier monitors can reside within the same 3500 rack, which increases the overall flexibility of the 3500 system. Users can upgrade standard monitors to those that contain internal barriers by replacing existing I/O modules.

Installation Guidelines

A 3500 rack containing Internal Barriers uses Monitor I/O Modules that incorporate barriers. These barriers provide explosion protection for transducer systems that are connected to the 3500 system. An intrinsically safe (IS) earthing module provides the IS earth connection through the 3500 system backplane. Installations use the same method to connect the hazardous area cable shields.

The IS Earth Module requires a dedicated I/O module position and precludes the use of this monitor position for other 3500 System modules. This limits a standard 19-inch rack to 13 monitor positions. In addition, a number of installation options are not available when Internal Barriers are installed in a 3500 rack. Note the following information when considering the use of Internal Barriers.

New Rack Installations

The same rack can contain both Internal Barrier and Standard I/O Module types without compromising the separation between hazardous and safe area field wiring.



The External Termination option is not available for I/O modules with Internal Barriers (Hazardous Area Approvals do not allow the use of intrinsically safe wiring within a multi-cored cable assembly).

Monitors that contain TMR rack options cannot use Internal Barrier I/O Modules, connecting a transducer to multiple I/O module inputs will compromise the integrity of the IS system.

A rack that contains any Internal Barrier modules **must have** a 3500/04-01 IS Earthing Module to provide the Barrier Module IS earth connection.

I/O Module Positioning

Internal Barrier I/O Modules have an increased depth over that of Standard Barrier I/O Modules. Consider the rack position with respect to adjacent modules to ensure that you can easily access these I/O modules during maintenance.

Internal Barrier I/O and IS Earthing Modules can occupy any general-purpose rack position, and can be adjacent to Standard I/O Module types without (?) compromising the 50 mm (2 in) physical separation requirement between 'Safe' and 'Hazardous' area field wiring.

Grouping all Internal Barrier I/O Modules in adjacent rack positions will simplify the installation. You should locate the IS Earthing Modules in a rack position that provides easy access for routine online maintenance. You should also consider its positioning relative to adjacent Internal Barrier I/O Modules and cabinet bulkheads.

If you plan to install Standard I/O Modules or an IS Earthing Module between a pair of Internal Barrier I/O Modules, allow a minimum of 2 rack position to ensure that you can easily access the Standard I/O or IS Earthing Module online without disturbing the installation of adjacent I/O modules.

Upgrading a 3500 Rack

Users can upgrade a 3500 rack with standard I/O Modules to a rack containing one or more Internal Barrier I/O Modules. by replacing the standard I/O Modules with the appropriate Internal Barrier Modules (see Spares). An IS Earthing Module must be installed in a dedicated monitor position. The IS Earthing Module can be ordered separately (see Spares).

Revision 2.3 or later of 3500 Configuration Software is required to enable the use of Internal Barriers with the following monitor types: /25, /40, /42, /50, /60, /61, /62, /70, /72.

The following Firmware revisions are required:

Table 1: Firmware Revision Requirements

Monitor	Firmware Version	Firmware Rev
3500/25	1.06	D or later
3500/50	1.05	E or later
3500/60	1.06	E or later
3500/61	1.06	E or later
3500/62	1.06	C or later

No firmware revisions are required for the 3500/40M, 3500/42M, 3500/70M, or 3500/72M monitors. (?)

Cabinet and Panel Installations

The Internal Barrier I/O Modules add approximately 50 mm (2 in) to the depth of the rack to provide the 50 mm (2 in) physical separation between 'Safe' and 'Hazardous' area field wiring. This means that a standard rack with Internal Barrier Modules will not fit into a 400 mm cabinet. The Bulkhead rack version is available for installations that require this cabinet type. A standard rack with Internal Barrier Modules will fit comfortably in a 600 mm and the 3500/06 Weatherproof Housing.

The following information provides suggested installations for the Internal Barriers within a cabinet or panel:

- The positioning of the 'Hazardous' and 'Safe' area connectors dictates that installations route the 'Hazardous' area field wiring above the 3500 rack and 'Safe' area wiring below the 3500 Rack.
- Installations should carefully route the Safe area wiring from the bulkhead version along the top of the 3500 rack to maintain the 50 mm (2 in) separation between safe and hazardous area wiring.

When multiple racks are installed within the same cabinet, hazardous area and safe area wiring can share the same cable trays providing that the cable trays provide a physical separator.

Specifications

Proximity / Acceleration

Bandwidth:

30 kHz

Amplitude

Accuracy:

3% @ 10 kHz,
-15/+10% @ 30 kHz

Phase Accuracy:

-11° @ 10 kHz

Circuit

Parameters:

Power (PWR):

$U_o = 26.8 \text{ V}$
 $R_{min} = 237.6 \ \Omega$
 $I_o = 112.8 \text{ mA}$

Signal (SIG):

$U_o = 14.05 \text{ V}$
 $R_{min} = 4985 \ \Omega$
 $I_o = 2.82 \text{ mA}$

Channel

Parameters:

$U_m = 250 \text{ V}$
 $U_o = 28 \text{ V}$
 $I_o = 115.62 \text{ mA}$
 $C_o = 0.083 \ \mu\text{F}$
 $L_o = 2.99 \text{ mH}$
 $P_o = 758 \text{ mW}$

Velomitor®

Amplitude

Accuracy:

±1%

Circuit

Parameters:

$U_o = 27.25 \text{ V}$

$R_{min} = 297 \ \Omega$

$I_o = 91.8 \text{ mA}$

Channel

Parameters:

$U_m = 250 \text{ V}$

$U_o = 27.25 \text{ V}$

$I_o = 91.8 \text{ mA}$

$C_o = 0.088 \ \mu\text{F}$

$L_o = 4.75 \text{ mH}$

$P_o = 625 \text{ mW}$

Temperature

Temperature

Accuracy:

±1 °C @ +25 °C, ±15 °C
over operating temperature

Circuit

Parameters:

Channel B:

$U_o = 5.44 \text{ V}$

$R_{min} = 134.5 \ \Omega$

$I_o = 40.45 \text{ mA}$

Channel C:

$U_o = 6.67 \text{ V}$

$R_{min} = 134.5 \ \Omega$

$I_o = 49.59 \text{ mA}$

Channel

Parameters:

$U_m = 250 \text{ V}$

$U_o = 7.87 \text{ V}$

$I_o = 90.04 \text{ mA}$

$C_o = 8.8 \ \mu\text{F}$

$L_o = 4.89 \text{ mH}$

$P_o = 136.4 \text{ mW}$

Process Variable

Circuit Parameters:

Power (PWR):

$$U_o = 27.52 \text{ V}$$

$$R_{\min} = 297 \ \Omega$$

$$I_o = 92.7 \text{ mA}$$

Signal (SIG):

$$U_o = 9.82 \text{ V}$$

$$R_{\min} = 50.58 \ \Omega$$

$$I_o = 194.2 \text{ mA}$$

Channel Parameters:

$$U_m = 250 \text{ V}$$

$$U_o = 28.72 \text{ V}$$

$$I_o = 286.9 \text{ mA}$$

$$C_o = 0.076 \ \mu\text{F}$$

$$L_o = 0.486 \text{ mH}$$

$$P_o = 889 \text{ mW}$$

Aeroderivative

See Proximity / Acceleration

Dynamic Pressure

See Proximity / Acceleration

Hazardous Area Approvals

CSA/NRTL/C

A/Ex nC[ia] IIC

Class I, Zone 2/(0)

Class I, Div I, Groups A,B,C,D

T4 @ Ta = -20 °C to +65 °C

(-4 °F to +150 °F)

Certification Number

CSA 1389797 (LR 26744-211)

ATEX

 II 1 G

[EEx ia] IIC

T4 @ Ta = -20 °C to +65 °C

(-4 °F to +150 °F)

Certification Number

LCIE 04 ATEX 6161X

Environmental Limits

Operating Temperature:

0 °C to +65 °C (+32 °F to +150 °F)

Storage Temperature:

-40 °C to +85 °C (-40 °F to +185 °F)

Humidity:

95%, noncondensing

Electromagnetic Compatibility

Radiated Emissions:

EN 55011, Class A.

Electrostatic Discharge:

EN 61000-4-2 (1995), Criteria B.

Radiated Susceptibility:

ENV 50140 (1993), Criteria A.

Conducted Susceptibility:

ENV 50141 (1993), Criteria A.

Electrical Fast Transient:

EN 61000-4-4, Criteria B.

Surge Capability:

EN 61000-4-5, Criteria B.

Magnetic Field:

EN 61000-4-8, Criteria A.

Power Supply Dip:

EN 61000-4-11, Criteria B.

Radio Telephone:

ENV 50204, Criteria B.

Physical

Internal Barrier I/O Module

Dimensions (Height x Width x Depth):

241.3 mm x 24.4 mm x 163.1 mm
(9.50 in. x 0.96 in. x 6.42 in.).

Weight:

0.46 kg (1.01 lb).

Internal Barrier Earthing Module

Dimensions (Height x Width x Depth):

241 mm x 24.4 mm x 103.1 mm
(9.50 in. x 0.96 in. x 4.06 in.).

Weight:

0.201 kg (0.443 lb.).

Ordering Information

3500/04-01

IS Earthing Module

Note: Order Internal Barriers by specifying the appropriate I/O Module type for each monitor module, and install an IS Earthing Module (p/n 3500/04-01) in each rack containing internal barriers. Consult Specifications and Ordering Information for each 3500 monitor module to order the appropriate I/O module.

Spares

3500/04-01

Internal Barrier Earthing Module (includes front panel).

135473-01

3500/25 I/O Module with Internal Barriers and Internal Terminations.

135489-04

3500/40 I/O Module with Internal Barriers and Internal Terminations.

135489-01

3500/42, /70, /72 I/O Module with Internal Barriers (4 x prox./accel. ch's) and Internal Terminations (option A04).

135489-02

3500/42, /70, /72 I/O Module with Internal Barriers (2 x prox./accel. + 2x Velomitor ch's) and Internal Terminations (option A05).

135489-03

3500/42, /70, /72 I/O Module with Internal Barriers (4 x Velomitor channels) and Internal Terminations

Graphs and Figures

Compatible Monitors	
	3500/25 Keyphasor® Monitor 3500/40M Proximitor Monitor 3500/42M Proximitor/Seismic Monitor 3500/44M Aeroderivative 3500/50 Tachometer Monitor 3500/60 Temperature Monitor 3500/61 Temperature Monitor with Recorders 3500/62 Process Variable Monitor 3500/64 Dynamic Pressure Monitor 3500/70M Recip Impulse/Velocity Monitor 3500/72M Recip Rod Position Monitor
Compatible Transducer Systems	
<i>Proximity:</i>	3300 XL Proximitor Sensor 3300 5 mm Proximitor Sensor 3300 8 mm Proximitor Sensor 3300 RAM Proximitor Sensor 7200 5 & 8 mm Proximitor Sensor
<i>Acceleration:</i>	23733-03 Standard Acceleration Transducer 330400 Standard Integral Acceleration Transducer 330425 Standard Integral Acceleration Transducer 49578-01 Standard Acceleration Transducer Modifies 86517 Interface Module
<i>Velocity:</i>	Velomitor® High Temperature Velomitor
<i>Temperature:</i>	3-wire Thermocouples: Type J Type K Type E Type T 3-wire RTDs: 10 Ω 3-wire Copper 100 Ω 3-wire Platinum 120 Ω 3-wire Nickel
<i>Process Variable</i>	+4 to +20 mA.
The Internal Barrier system does not support the following transducer systems:	
	11 mm, 14 mm, 16 mm, 25 mm, 35 mm, or 50 mm Proximitor® Sensors Velocity Seismoprobe (/42) Velocity-to-Displacement Converter (/40) Magnetic pick-up (/50) 4-wire RTDs and Thermocouples (/60, /61) 1-5 Vdc Process Variables (/62) 0-10 Vdc Process Variables (/62)
Note: Internal barriers have been designed to be compatible with approved BNC Transducer Systems. In most cases, non- BNC transducer systems are not compatible with 3500 Internal Barriers. Consult your local Bently Nevada Sales Professional for more information.	

Table 2: Monitors and Transducers compatible with 3500 Internal Barriers

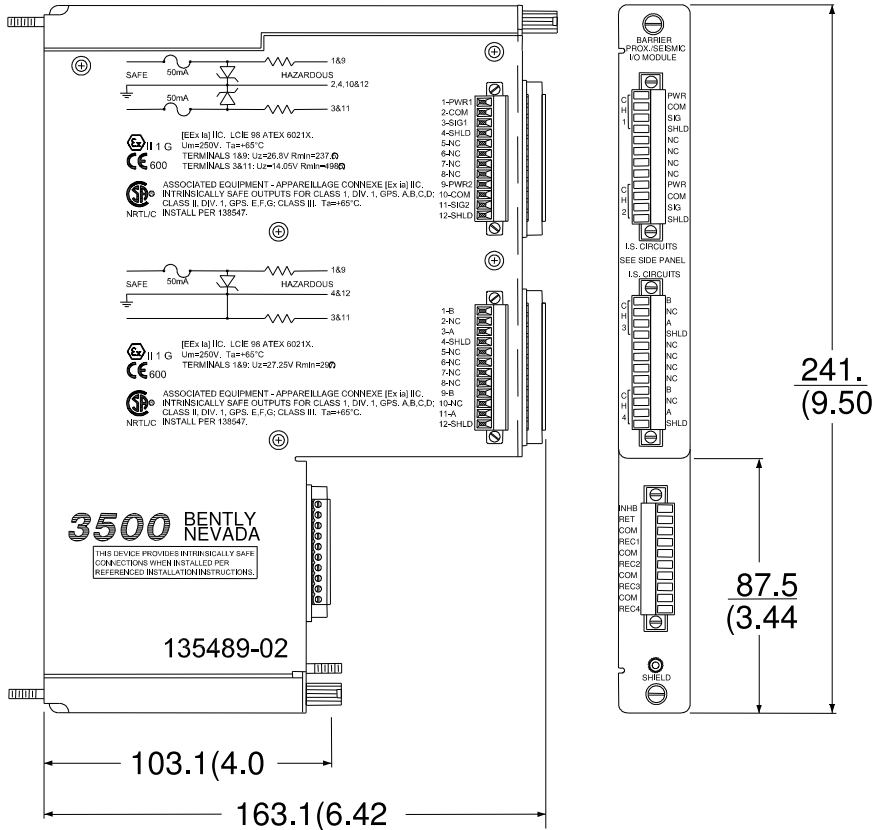

Typical Internal Barrier I/O Module

Figure 1: Typical Internal Barrier I/O Module

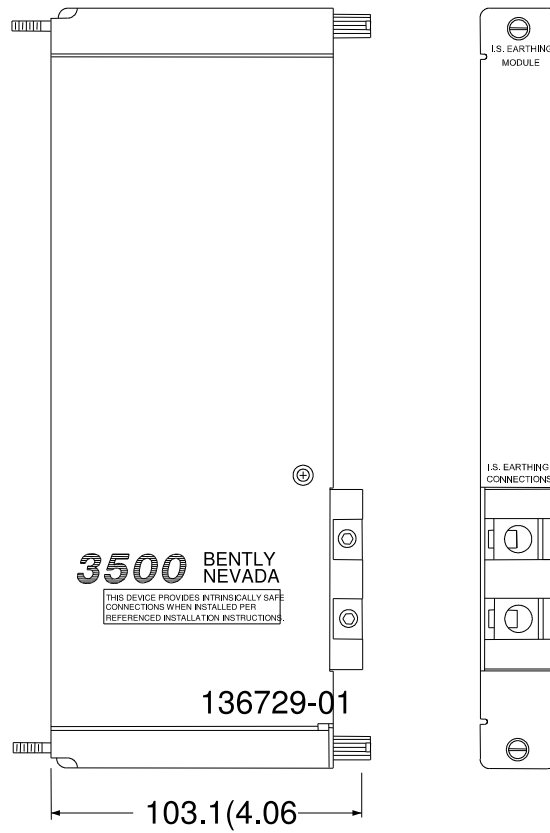

3500/04-01 Internal Barrier Earthing Module

Figure 2: Rear views of the 3500/04-01 Internal Barrier Earthing Module

Dimensions are in millimetres (inches)

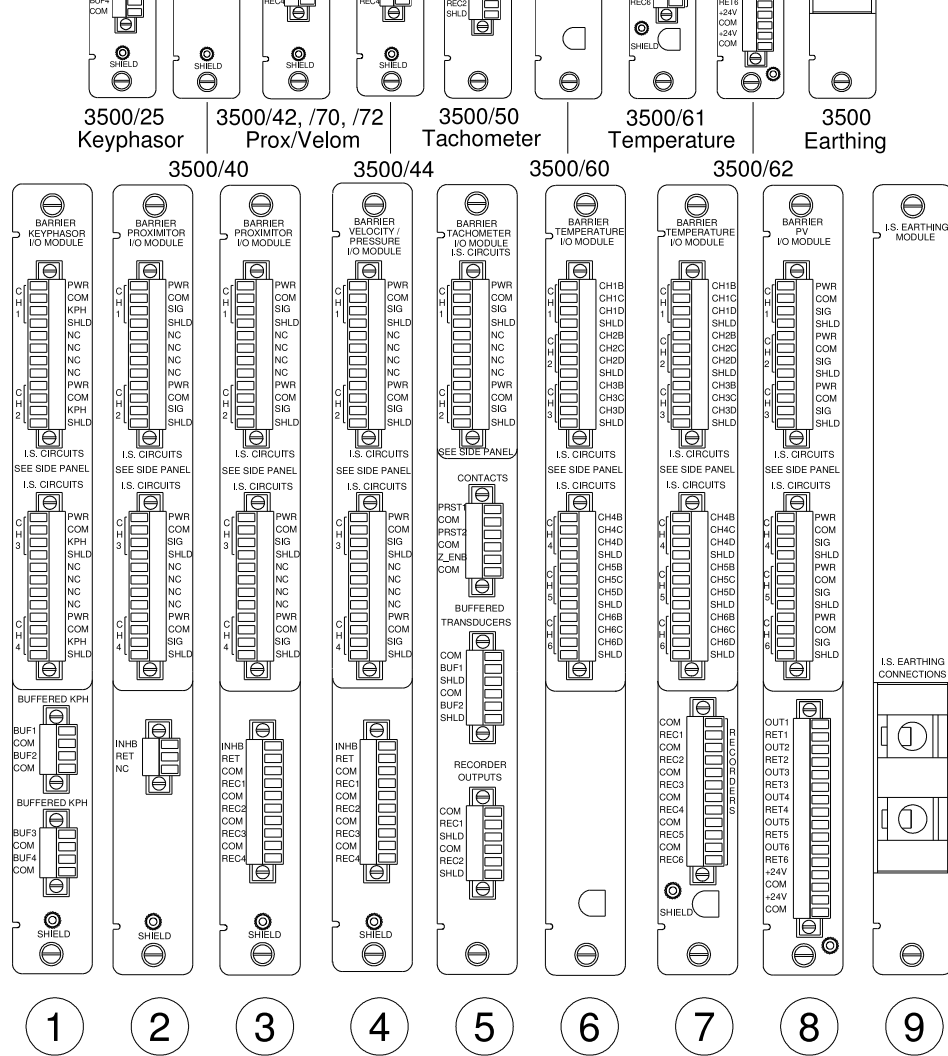

1. 3500/25 Keyphasor
2. 3500/40M Proximity
3. 3500/42M, /70M, /72M Prox/Velom
4. 3500/44M, /64 Vel/Pressure
5. 2500/50 Tachometer
6. 3500/60 Temperature
7. 3500/61 Temperature
8. 3500/62 Process
9. 3500 Earthing

Figure 3: Typical Internal Barrier Installation

Copyright 2000. Bently Nevada LLC.
 1631 Bently Parkway South, Minden, Nevada USA 89423
 Phone: 775.782.3611 Fax: 775.215.2873
www.ge-energy.com/bently
 All rights reserved.

Bently Nevada, Proximitor and Velomitor are trademarks of General Electric Company.