

# Fisher® FIELDVUE™ DVC6200 Series Digital Valve Controllers

## Contents

Before You Begin .....	3
Step 1. Install the DVC6200 on the Valve .....	4
Step 2. Connect the Pneumatic Tubing .....	19
Step 3. Connect the Electrical Wires .....	23
Step 4. Configure the DVC6200 .....	33
Special Instructions for Safety Instrumented Systems .....	35
Hazardous Area Approvals and Special Instructions for “Safe Use” and Installations in Hazardous Locations .....	43



W9713

This quick start guide provides installation and initial setup information for DVC6200 Series digital valve controllers





## Related Documents

The following documents include product specifications, reference materials, custom setup information, maintenance procedures, and replacement part details.

If a copy of any of these documents is needed scan or click the appropriate code below, contact your [Emerson Process Management sales office](#), or visit our website at [www.Fisher.com](http://www.Fisher.com).



### DVC6200

[DVC6200 HW1 Instruction Manual \(D103409X012\)](#)

[DVC6200 HW2 Instruction Manual \(D103605X012\)](#)



DVC6200

Scan or click code for digital valve controller field support

### DVC6200f

[DVC6200f Instruction Manual \(D103412X012\)](#)



DVC6200f

### DVC6200 SIS

[DVC6200 SIS Instruction Manual \(D103557X012\)](#)

[Safety manual for DVC6200 SIS \(D103601X012\)](#)



DVC6200 SIS

### DVC6200p

[DVC6200p Instruction Manual \(D103563X012\)](#)



DVC6200p

For information on installation and usage of DVC6200 Series digital valve controllers, visit the Fisher channel on YouTube and search for FIELDVUE.

<http://www.youtube.com/user/FisherControlValve>



## Before You Begin

Do not install, operate, or maintain a DVC6200 digital valve controller without being fully trained and qualified in valve, actuator, and accessory installation, operation, and maintenance. To avoid personal injury or property damage, it is important to carefully read, understand, and follow all contents of this quick start guide, including all safety cautions and warnings. Refer to Hazardous Area Approvals and Special Instructions for “Safe Use” and Installations in Hazardous Locations, on page 43, for approval specific safe use information. If you have any questions about these instructions, contact your [Emerson Process Management sales office](#) before proceeding.

### **⚠ WARNING**

**Avoid personal injury or property damage from sudden release of process pressure or bursting of parts. Before proceeding with any Installation procedures:**

- Always wear protective clothing, gloves, and eyewear to prevent personal injury or property damage.
- Do not remove the actuator from the valve while the valve is still pressurized.
- Disconnect any operating lines providing air pressure, electric power, or a control signal to the actuator. Be sure the actuator cannot suddenly open or close the valve.
- Use bypass valves or completely shut off the process to isolate the valve from process pressure. Relieve process pressure from both sides of the valve.
- Use lock-out procedures to be sure that the above measures stay in effect while you work on the equipment.
- Check with your process or safety engineer for any additional measures that must be taken to protect against process media.
- Vent the pneumatic actuator loading pressure and relieve any actuator spring precompression so the actuator is not applying force to the valve stem; this will allow for the safe removal of the stem connector.

### **⚠ WARNING**

**To avoid static discharge from the plastic cover when flammable gases or dust are present, do not rub or clean the cover with solvents. To do so could result in a spark that may cause the flammable gases or dust to explode, resulting in personal injury or property damage. Clean with a mild detergent and water only.**



# Step 1—Install the DVC6200 on the Valve

## Housing Variations

The DVC6200 housing is available in two different configurations, depending on the actuator mounting method. Figure 1 shows the available configurations.

Figure 1. Housing Variations

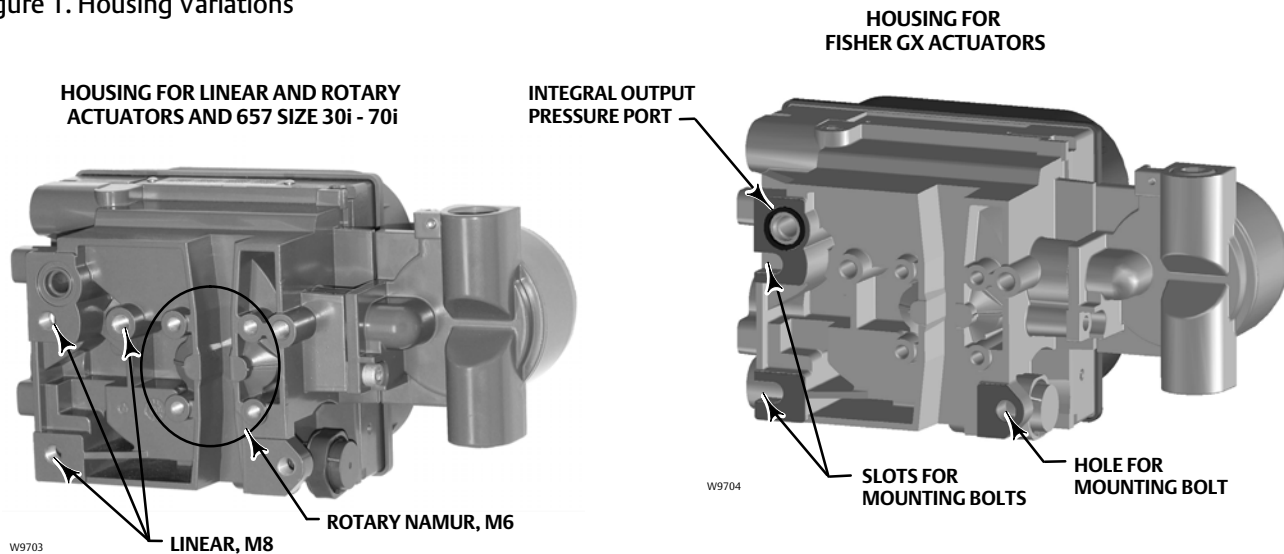

## General Mounting Guidelines

If ordered as part of a control valve assembly, the factory will mount the digital valve controller on the actuator and calibrate the instrument. If you purchased the digital valve controller separately, you will need a mounting kit. The following procedures are general guidelines. See the instructions that come with the mounting kit for detailed information on mounting the digital valve controller to a specific actuator model.

### CAUTION

The magnet assembly material has been specifically chosen to provide a long-term stable magnetic field.

However, as with any magnet, care must be taken when handling the magnet assembly. Another high powered magnet placed in close proximity (less than 25 mm) can cause permanent damage. Potential sources of damaging equipment include, but are not limited to: transformers, DC motors, stacking magnet assemblies.

#### General Guidelines for use of High Power Magnets with Positioners

Use of high power magnets in close proximity to any positioner which is operating a process should be avoided. Regardless of the positioner model, high power magnets can affect the positioner’s ability to control the valve.

**Use of Magnetic Tools with the DVC6200**

- **Magnetic Tip Screw Drivers** – Magnetic tip screw drivers can be used to work on the DVC6200. However, they should not be brought in close proximity to the magnet assembly (located at the back of the instrument) during process operations.
- **Calibrator Strap Magnets** – These are high power magnets used to hold 4-20 mA calibrators. Normally, these calibrators would not be used while an instrument is controlling the process. High power magnets should be kept at least 15 cm (6 inches) from the DVC6200.



**Note**

- The mounting instructions also apply to the DVC6215 remote mount feedback unit.
- As a general rule, do not use less than 60% of the magnet assembly travel range for full travel measurement. Performance will decrease as the assembly is increasingly subranged.
- The linear magnet assemblies have a valid travel range indicated by arrows molded into the piece. This means that the hall sensor (the center point of the channel on the back of the DVC6200 housing) has to remain within this range throughout the entire valve travel. The linear magnet assemblies are symmetrical. Either end may be up.
- The magnet assembly may be referred to as a magnetic array in user interface tools.
- Mounting the instrument vertically, with the vent at the bottom of the assembly, or horizontally, with the vent pointing down, is recommended to allow drainage of moisture that may be introduced via the instrument air supply.

**For sliding-stem linear actuators proceed to page 6**

Bracket Mounted .....	6
667 and 657 .....	6
Actuators over 210 mm (8.25 inches Travel) .....	8
Integral Mounted Fisher Actuators .....	9
Air-to-Open (GX) .....	10
Air-to-Close (657 Size 30i - 70i or GX) .....	12

**For quarter-turn rotary actuators proceed to page 14**

Integral Mounted Fisher Actuators .....	14
Bracket Mounted .....	15

## Sliding-Stem Linear Actuators

### Bracket Mounted

#### Fisher 667 and 657

1. Isolate the control valve from the process line pressure and release pressure from both sides of the valve body. Shut off all pressure lines to the actuator, releasing all pressure from the actuator. Use lock-out procedures to be sure that the above measures stay in effect while you work on the equipment.

Figure 2. Mounting Parts for Sliding-Stem Actuator with up to 210 mm (8.25 inches) Travel

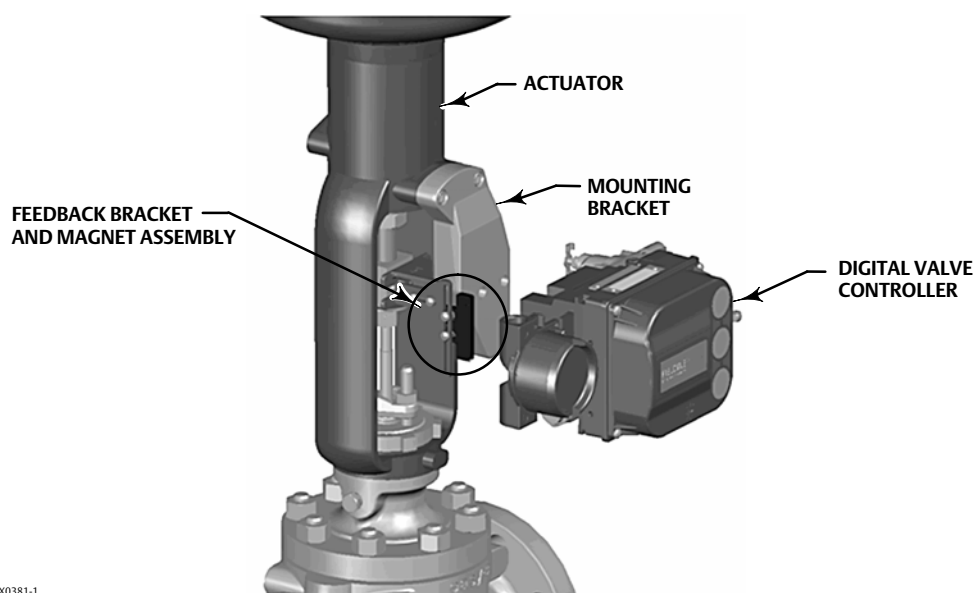

X0381-1

2. Attach the mounting bracket to the actuator.
3. Loosely attach the feedback pieces and magnet assembly to the valve stem connector. Do not tighten the fasteners because fine adjustment is required.

### CAUTION

**Do not install a magnet assembly that is shorter than the physical travel of the actuator. Loss of control will result from the magnet assembly moving outside the range of the index mark in the feedback slot of the DVC6200 housing.**

4. Using the alignment template (supplied with the mounting kit), position the magnet assembly inside the retaining slot.
5. Align the magnet assembly as follows:
  - For air-to-open actuators (e.g. Fisher 667) vertically align the magnet assembly so that the center line of the alignment template is lined up as close as possible with the upper extreme of the valid travel range on the magnet assembly. The magnet assembly should be positioned so that the index mark in the feedback slot of the DVC6200 housing is within the valid range on the magnet assembly throughout the range of travel. See figure 3.

- For air-to-close actuators (e.g. Fisher 657) vertically align the magnet assembly so that the center line of the alignment template is lined up as close as possible with the lower extreme of the valid travel range on the magnet assembly. The magnet assembly should be positioned so that the index mark in the feedback slot of the DVC6200 housing is within the valid range on the magnet assembly throughout the range of travel. See figure 4.

Figure 3. Air-to-Open Magnet Assembly Alignment

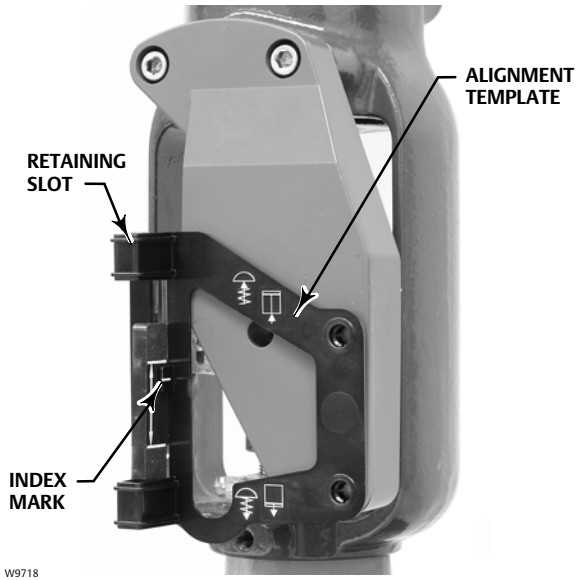
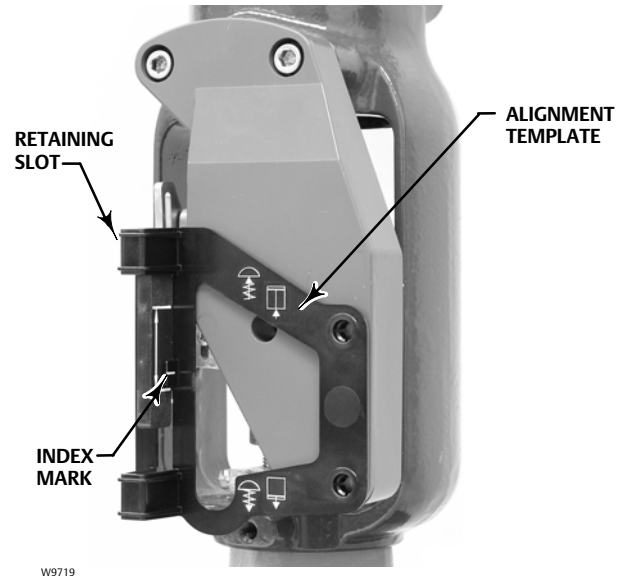

Figure 4. Air-to-Close Magnet Assembly Alignment



6. Tighten the fasteners and remove the alignment template.

**Note**

Use a flat end hex key to tighten the magnet assembly fasteners to a torque of 2.37 N•m (21 lbf•in) for 4 mm screws, and 5.08 N•m (45 lbf•in) for 5 mm screws. For added security, especially in vibrating services, blue (medium) threadlocker may be used on the fasteners.

7. Mount the digital valve controller to the mounting bracket, using the mounting bolts.

8. Check for clearance between the magnet assembly and the DVC6200 feedback slot.

**Note**

Ensure that there is clearance between the magnet assembly and the DVC6200 housing slot throughout the full range of travel.

9. For remote mount applications, proceed to page 17 for DVC6205 base unit mounting. Otherwise, proceed to Step 2—Connect the Pneumatic Tubing on page 19.

**Actuators over 210 mm (8.25 inches) Travel**

1. Isolate the control valve from the process line pressure and release pressure from both sides of the valve body. Shut off all pressure lines to the pneumatic actuator, releasing all pressure from the actuator. Use lock-out procedures to be sure that the above measures stay in effect while working on the equipment.

Figure 5. Mounting on Sliding-Stem (Linear) Actuators over 210 mm (8.25 Inches) Travel

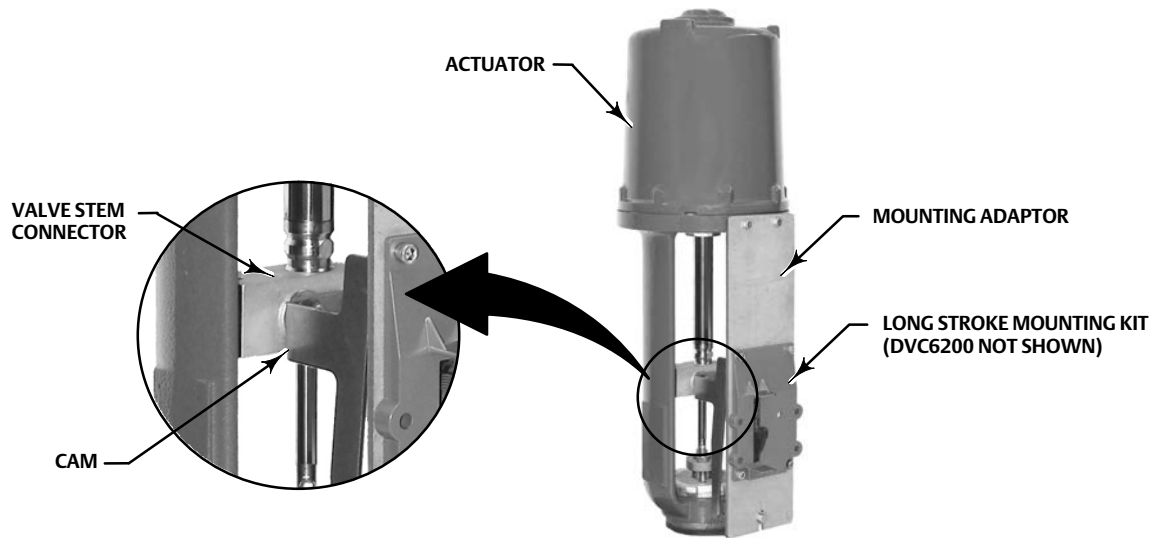

W9709

2. Install the cam to the valve stem connector as described in the instructions included with the mounting kit.
3. Install the mounting adaptor to the actuator.
4. Attach the digital valve controller and mounting kit assembly to the mounting adaptor. The roller on the digital valve controller feedback arm will contact the actuator cam as it is being attached.

Figure 6. Roller Arm Variation used for Sliding-Stem (Linear) Actuators over 210 mm (8.25 Inches) Travel

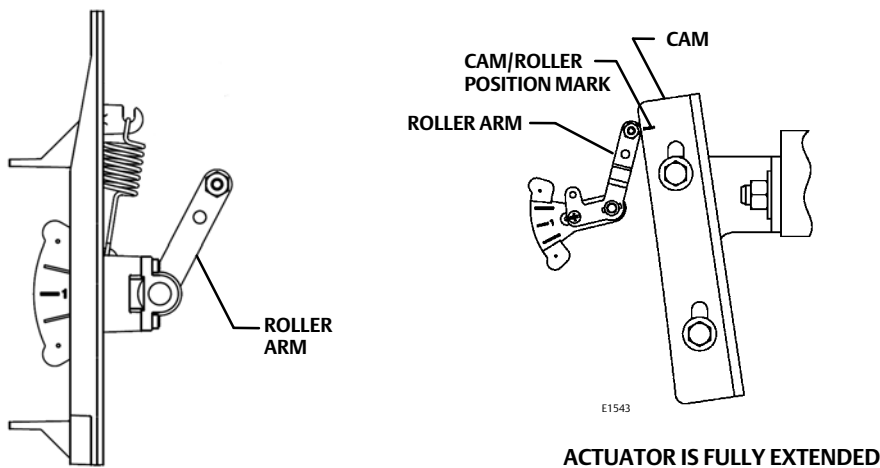

E1229

E1543

5. For remote mount applications, proceed to page 17 for DVC6205 base unit mounting. Otherwise, proceed to Step 2—Connect the Pneumatic Tubing on page 19.



## Integral Mounted Fisher Actuators

1. Isolate the control valve from the process line pressure and release pressure from both sides of the valve body. Shut off all pressure lines to the actuator, releasing all pressure from the actuator. Use lock-out procedures to be sure that the above measures stay in effect while you work on the equipment.
2. The DVC6200 digital valve controller mounts directly to an integral mounted Fisher actuator without the need for a mounting bracket. Make sure you have the correct DVC6200 housing for your actuator, as shown in figure 1.
3. For GX actuators, identify the yoke side to mount the DVC6200 digital valve controller based on the actuator fail mode. Refer to the [GX Control Valve and Actuator System instruction manual \(D103175X012\)](#).
4. Loosely attach the feedback pieces and magnet assembly to the valve stem connector. Do not tighten the fasteners because fine adjustment is required.

### CAUTION

**Do not install a magnet assembly that is shorter than the physical travel of the actuator. Loss of control will result from the magnet assembly moving outside the range of the index mark in the feedback slot of the DVC6200 housing.**

---

5. Using the alignment template (supplied with the mounting kit), position the feedback assembly inside the retaining slot.
6. Continue on with the appropriate procedure below to align the magnet assembly.

## Air-to-Open (GX)

Vertically align the magnet assembly so that the center line of the alignment template is lined up as close as possible with the upper extreme of the valid travel range on the magnet assembly. The magnet assembly should be positioned so that the index mark in the feedback slot of the DVC6200 housing is within the valid range on the magnet assembly throughout the range of travel. See figure 7.

Figure 7. Air-to-Open Magnet Assembly Alignment

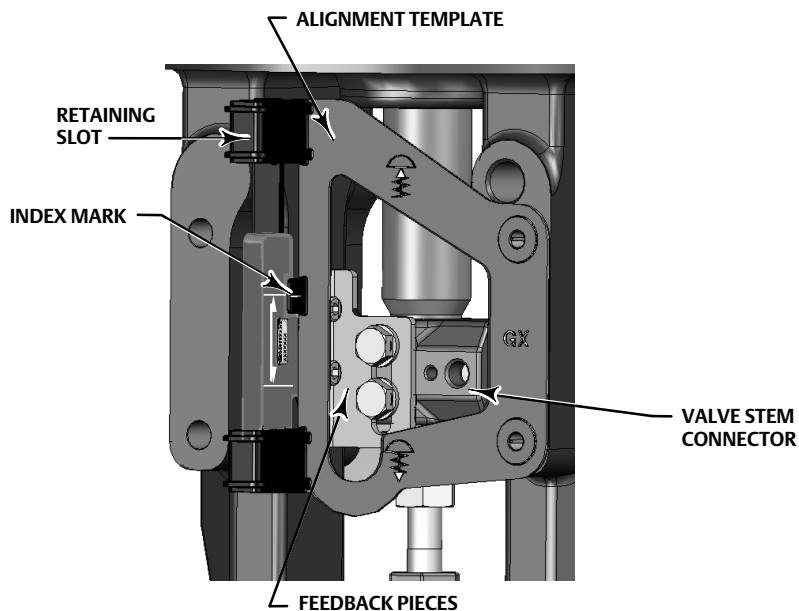

1. Tighten the fasteners and remove the alignment template.

### Note

Use a flat end hex key to tighten the magnet assembly fasteners to a torque of 2.37 N•m (21 lbf•in) for 4 mm screws, and 5.08 N•m (45 lbf•in) for 5 mm screws. For added security, especially in vibrating services, blue (medium) threadlocker may be used on the fasteners.

2. Remove the plug (R1/8) from the back of the DVC6200 housing. This pneumatic output port on the DVC6200 lines up with the integral GX actuator pneumatic port. See figure 8.

Figure 8. Modifications for Fisher GX Actuator; Air-to-Open Construction Only

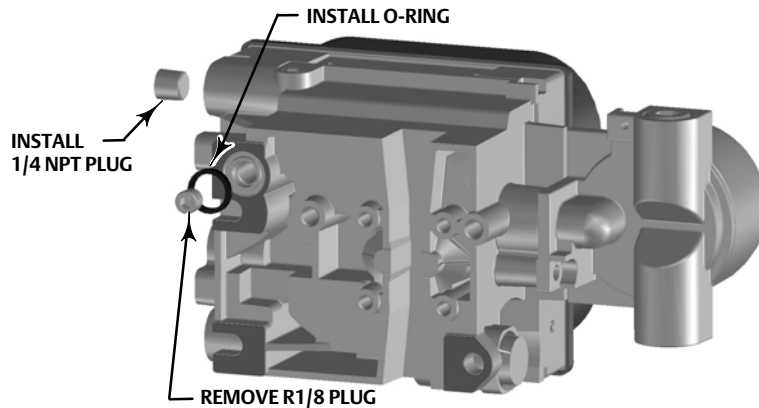

3. Install the plug (1/4 NPT, included in the mounting kit) to the external output pneumatic port A.
4. Using a 5 mm hex key, attach the digital valve controller to the GX actuator mounting pad on the side that has the open pneumatic port. Be sure to place the O-ring between the digital valve controller's pneumatic output and the actuator mounting pad. Pneumatic tubing is not required because the air passages are internal to the actuator.
5. Check for clearance between the magnet assembly and the DVC6200 feedback slot.
6. If not already installed, install a vent in the port on the upper diaphragm casing.
7. For remote mount applications, proceed to page 17 for DVC6205 base unit mounting. Otherwise, proceed to Step 2—Connect the Pneumatic Tubing on page 19.

### Air-to-Close (657 size 30i - 70i and GX)

Vertically align the magnet assembly so that the center line of the alignment template is lined up as close as possible with the lower extreme of the valid travel range on the magnet assembly. The magnet assembly should be positioned so that the index mark on the pole pieces (back of the DVC6200 housing) is within the valid range on the magnet assembly throughout the range of travel. See figure 9.

Figure 9. Air-to-Close Magnet Assembly Alignment

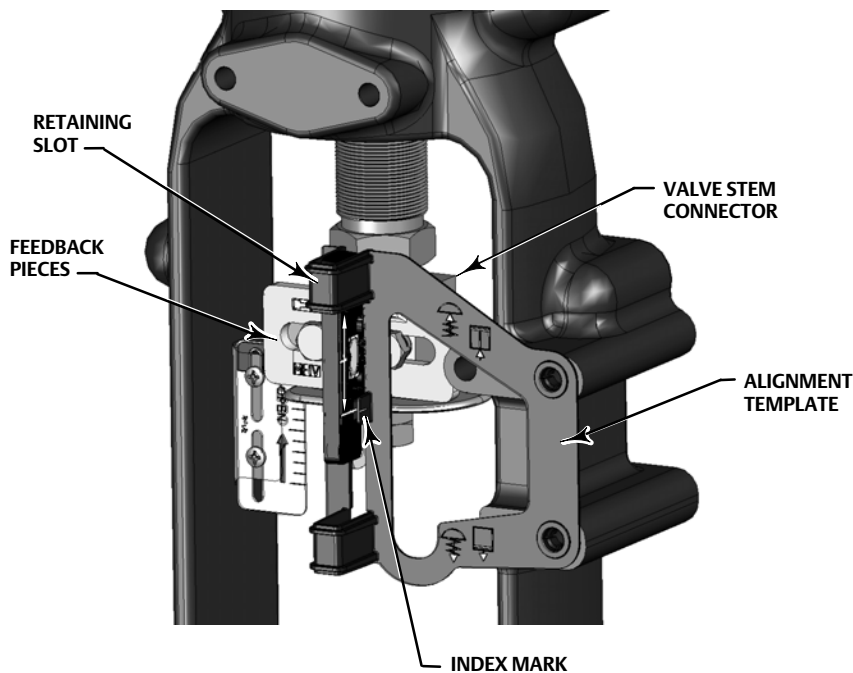

1. Tighten the fasteners and remove the alignment template.

#### **Note**

Use a flat end hex key to tighten the magnet assembly fasteners to a torque of 2.37 N•m (21 lbf•in) for 4 mm screws, and 5.08 N•m (45 lbf•in) for 5 mm screws. For added security, especially in vibrating services, blue (medium) threadlocker may be used on the fasteners.

2. Attach the digital valve controller to the actuator mounting pad.

---

**Note**

Use a 5 mm hex key to attach the digital valve controller the GX actuator mounting pad.

Use a 13 mm socket or box end wrench to attach the digital valve controller to the 657 size 30i -70i actuator mounting pad.

---

3. Check for clearance between the magnet assembly and the DVC6200 feedback slot.
4. Install tubing between the actuator casing and the appropriate DVC6200 pneumatic output port.
5. If not already installed, install a vent in the port on the lower diaphragm casing or yoke.
6. For remote mount applications, proceed to page 17 for DVC6205 base unit mounting. Otherwise, proceed to Step 2—Connect the Pneumatic Tubing on page 19.

---

**Note**

When field converting a GX actuator from air-to-close to air-to-open (or vice-versa), you will need to change the plugs for the pneumatic passages in the DVC6200 housing.

- To convert to air-to-open, remove the R1/8 pneumatic plug on the back of the DVC6200 housing and install an O-ring. Plug the external pneumatic output with a 1/4 NPT plug. Refer to figure 8.
  - To convert to air-to-close, remove the external pneumatic plug. Install an R1/8 plug on the back of the DVC6200 housing. Install tubing between the pneumatic output connection of the DVC6200 to the pneumatic port on top of the actuator casing.
- 

**Note**

Refer to the [657 Diaphragm Actuator Sizes 30/30i through 70/70i and 87 instruction manual \(D100306X012\)](#) for 657 product information.

Scan or click the code to see how to mount a DVC6200 digital valve controller to a 657 actuator with integrated mounting pad



Refer to the [GX Control Valve and Actuator System instruction manual](#) for GX product information.

---

## Quarter-Turn Rotary Actuators

### Integral Mounted Fisher Actuators

1. Isolate the control valve from the process line pressure and release pressure from both sides of the valve body. Shut off all pressure lines to the pneumatic actuator, releasing all pressure from the actuator. Use lock-out procedures to be sure that the above measures stay in effect while working on the equipment.
2. Verify that the appropriate cam is installed on the actuator as described in the instructions included with the mounting kit.

Figure 10. Mounting on Rotary Actuators

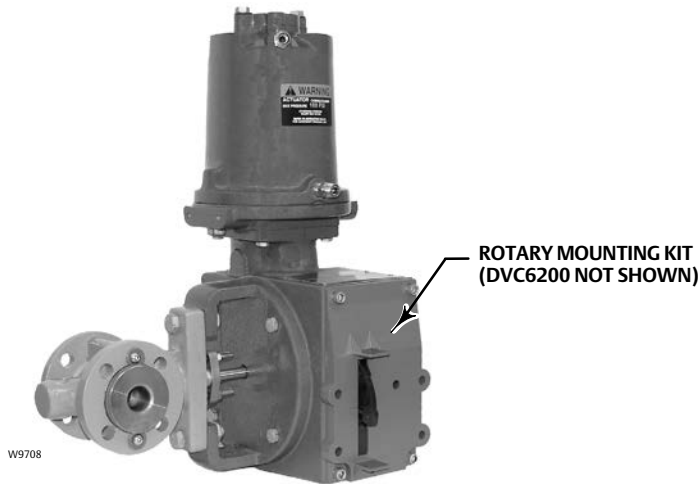
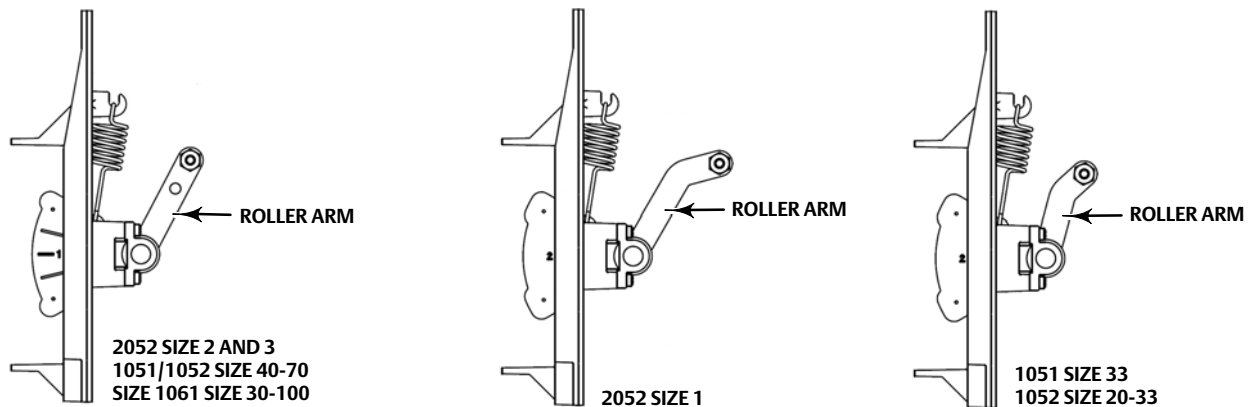

Figure 11. Rotary Actuator Mounting Variations



NOTE THE DIFFERENCE IN THE SHAPE AND LENGTH OF THE ROLLER ARM

E1229

3. Mount the DVC6200 on the actuator as follows:
  - If required, a mounting adaptor is included in the mounting kit. Attach the adaptor to the digital valve controller, then attach the digital valve controller assembly to the actuator. The roller on the digital valve controller feedback arm will contact the actuator cam as it is being attached.
  - If no mounting adaptor is required, attach the digital valve controller and mounting kit assembly to the actuator. The roller on the digital valve controller feedback arm will contact the actuator cam as it is being attached.
4. For remote mount applications, proceed to page 17 for DVC6205 base unit mounting. Otherwise, proceed to Step 2—Connect the Pneumatic Tubing on page 19.

## Bracket Mounted

The DVC6200 digital valve controller can be mounted to any quarter-turn rotary actuator, as well as those that comply with the NAMUR guidelines. A mounting bracket and associated hardware are required. Refer to figure 12.

1. Isolate the control valve from the process line pressure and release pressure from both sides of the valve body. Shut off all pressure lines to the actuator, releasing all pressure from the actuator. Use lock-out procedures to be sure that the above measures stay in effect while you work on the equipment.

Figure 12. Mounting on Quarter-Turn Actuators

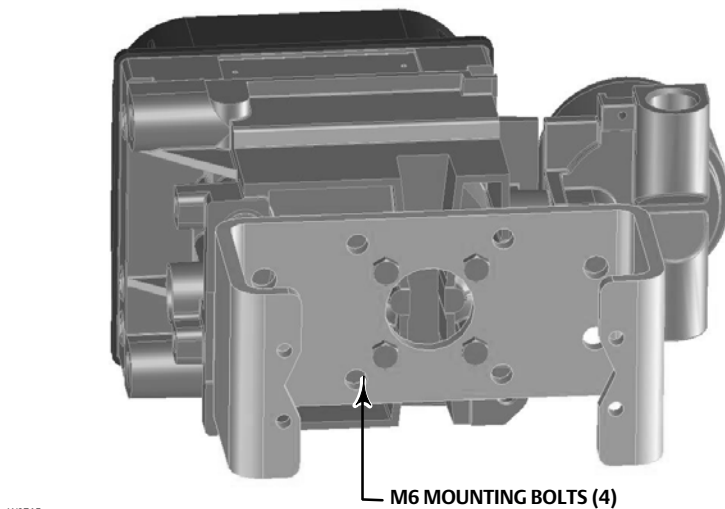

- Attach the magnet assembly to the actuator shaft. At mid-travel, the flats on the magnet assembly should be approximately parallel to the channel on the back of the DVC6200 housing, as shown in figure 13.

Figure 13. Magnet Assembly Orientation on Quarter-Turn Actuators

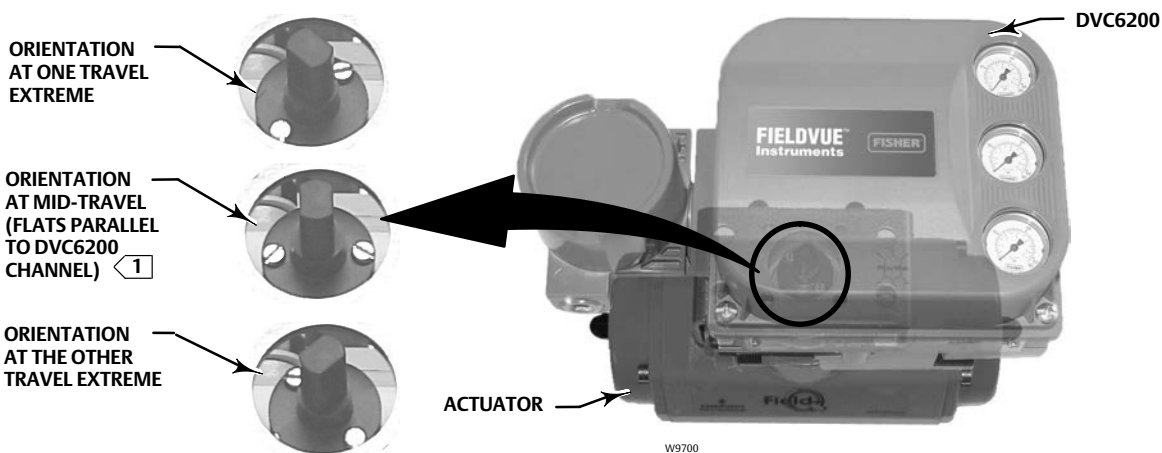

1 THIS EXAMPLE SHOWS AN ACTUATOR WITH 90° TRAVEL. ON AN ACTUATOR THAT HAS LESS THAN 90° TRAVEL THE MAGNET ASSEMBLY MAY NOT BE PARALLEL AT THE MID-TRAVEL POINT. TO VERIFY THE MAGNET ASSEMBLY POSITION IS IN WORKING RANGE, CONFIRM TRAVEL COUNTS ARE WITHIN THE EXPECTED RANGE OF 175-3800 USING VALVELINK SOFTWARE OR A FIELD COMMUNICATOR.

- Install the mounting bracket on the actuator.
- Attach the digital valve controller to the mounting bracket using the 4 mounting bolts, as shown in figure 12.
- Check for clearance between the magnet assembly and the DVC6200 feedback slot.
- For remote mount applications, proceed to page 17 for DVC6205 base unit mounting. Otherwise, proceed to Step 2—Connect the Pneumatic Tubing on page 19.



## DVC6205 Remote Mount Base Unit Mounting

For remote-mounted digital valve controllers, the DVC6205 base unit ships separately from the control valve and does not include tubing, fittings or wiring.

### Pipestand Mounting

1. Position a standoff on the back of the base unit.
2. Using two 101.6 mm (4-inch) 1/4-20 hex head screws loosely attach the base unit to the pipestand with the mounting bracket.
3. Position the second standoff, then using the remaining 101.6 mm (4-inch) hex head screws, securely fasten the base unit to the pipe stand.
4. Tighten all screws.
5. Proceed to Step 2—Connect the Pneumatic Tubing on page 19.

Figure 14. FIELDVUE DVC6205 Pipestand Mounting

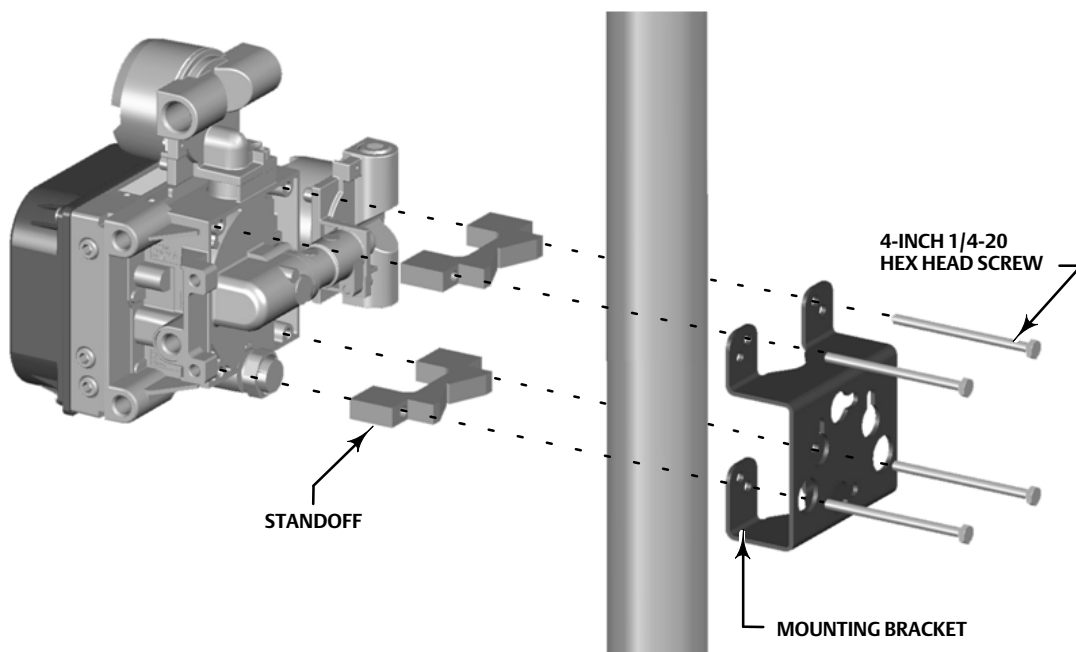

X0437

## Wall Mounting

1. Install the wall mounting screws by using the mounting bracket as a template.
2. Install the mounting bracket to the back of the base unit using the spacers and screws provided in the mounting kit.
3. Slide the assembly on the wall mounting screws and tighten.
4. Proceed to Step 2—Connect the Pneumatic Tubing on page 19.

Figure 15. FIELDVUE DVC6205 Wall Mounting

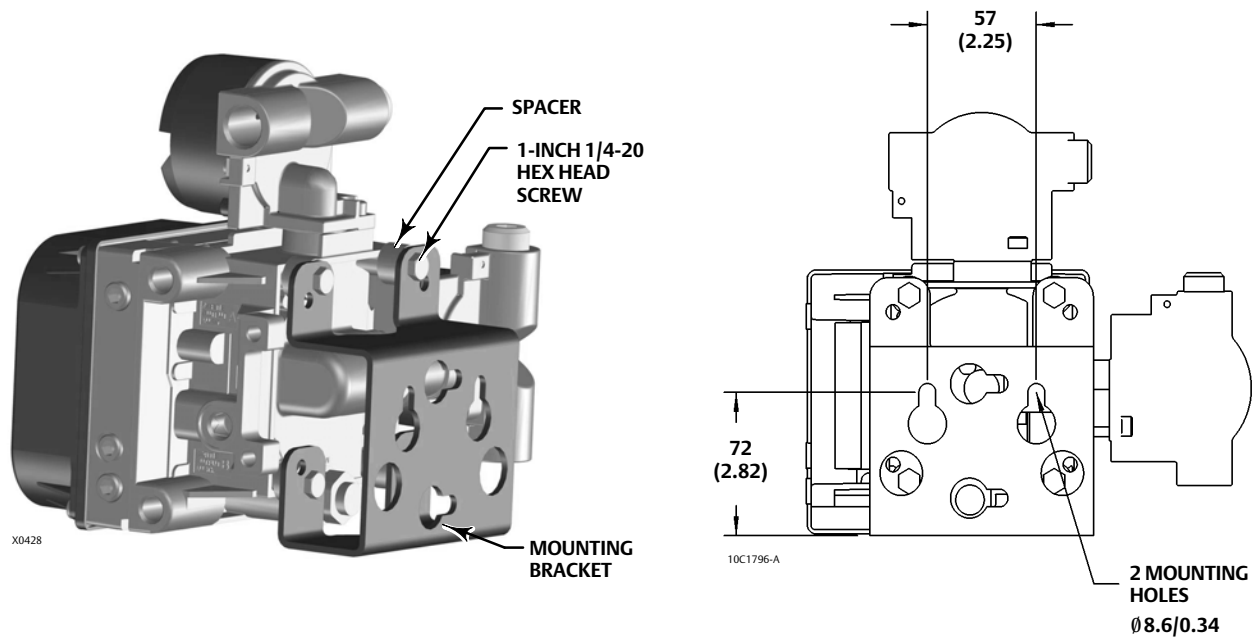



## Step 2—Connect the Pneumatic Tubing

Figure 16. Integral Mounting of a Fisher 67CFR Regulator on a FIELDVUE DVC6200 Digital Valve Controller

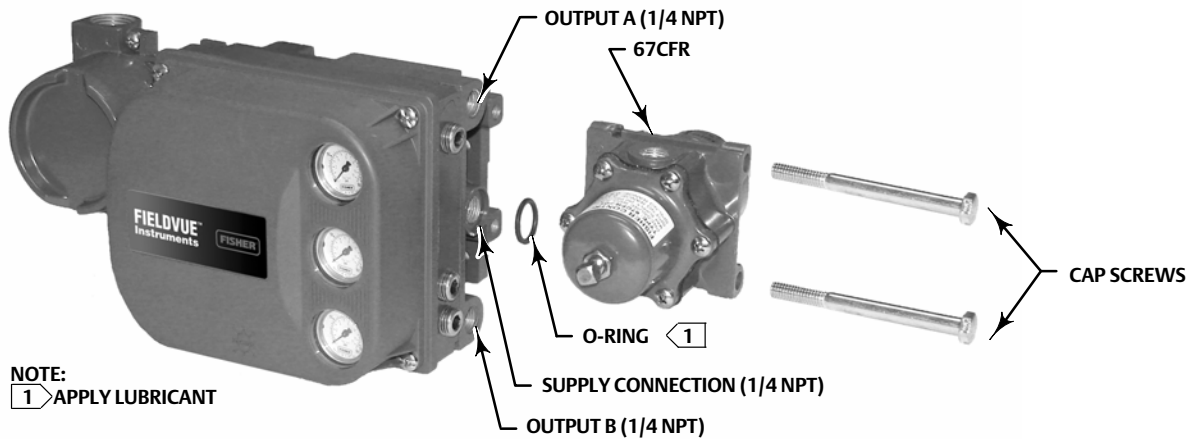

1. Connect the DVC6200 pneumatic output to the actuator input using at least 10 mm (3/8-inch) diameter tubing.
  - When using a single-acting direct digital valve controller (relay A or C) on a single-acting actuator, connect OUTPUT A to the actuator pneumatic input.
  - When using a single-acting reverse digital valve controller (relay B) on a single-acting actuator, connect OUTPUT B to the actuator diaphragm casing.
  - When using a double-acting digital valve controller (relay A) on a double-acting actuator, connect OUTPUT A and OUTPUT B to the appropriate actuator pneumatic input. With no input current to the DVC6200, OUTPUT A is at zero pressure and OUTPUT B is at full supply pressure when the relay is properly adjusted.

### Note

To have the actuator stem extend from the cylinder with increasing input signal, connect OUTPUT A to the actuator cylinder connection farthest from the actuator stem. Connect OUTPUT B to the cylinder connection closest to the actuator stem. To have the actuator stem retract into the cylinder with increasing input signal, connect OUTPUT A to the actuator cylinder connection closest to the actuator stem. Connect OUTPUT B to the cylinder connection farthest from the actuator stem.

**▲ WARNING**

Supply medium must be clean, dry, oil-free, and noncorrosive and meet the requirements of ISA Standard 7.0.01 or ISO 8573-1.

Severe personal injury or property damage may occur from an uncontrolled process if the instrument supply medium is not clean, dry, oil-free, and noncorrosive. While use and regular maintenance of a filter that removes particles larger than 40 micrometers in diameter will suffice in most applications, further filtration down to 5 micrometer particle size is recommended. Lubricant content is not to exceed 1 ppm weight (w/w) or volume (v/v) basis. Condensation in the air supply should be minimized.

Check with an Emerson Process Management field office and industry instrument air quality standards for use with corrosive air or if you are unsure about the amount of air filtration or filter maintenance.

When using natural gas as the supply medium, or for explosion-proof applications, the following warnings also apply:

- Remove electrical power before removing the housing cap. Personal injury or property damage from fire or explosion may result if power is not disconnected before removing the cap.
- Remove electrical power before disconnecting any of the pneumatic connections.
- When disconnecting any of the pneumatic connections or any pressure retaining part, natural gas will seep from the unit and any connected equipment into the surrounding atmosphere. Personal injury or property damage may result from fire or explosion if natural gas is used as the supply medium and appropriate preventive measures are not taken. Preventive measures may include, but are not limited to, one or more of the following: ensuring adequate ventilation and the removal of any ignition sources.
- Ensure that all caps and covers are correctly installed before putting this unit back into service. Failure to do so could result in personal injury or property damage from fire or explosion.

2. Connect a filter or filter regulator to the DVC6200 supply input using at least 10 mm (3/8-inch) diameter tubing.

- When using an integral mounted 67CFR filter regulator, lubricate an O-ring and insert it in the recess around the SUPPLY connection on the digital valve controller. Attach the filter regulator to the side of the digital valve controller. Thread a 1/4-inch socket-head pipe plug into the unused outlet on the filter regulator. This is the standard method of mounting the filter regulator. No tubing is required.
- When using a yoke mounted 67CFR filter regulator, mount the filter regulator with two cap screws to the pre-drilled and tapped holes in the actuator yoke. Thread a 1/4-inch socket-head pipe plug into the unused outlet on the filter regulator. No O-ring is required.
- When using a casing mounted filter regulator, use a separate casing mounting bracket (typically provided with the filter regulator). Attach the mounting bracket to the filter regulator and then attach this assembly to the actuator casing. Thread a 1/4-inch socket-head pipe plug into the unused outlet on the filter regulator. No O-ring is required.
- If the supply pressure is less than the maximum actuator and instrument pressure rating, a regulator is not required. However, a filter is always required. Attach the filter securely to the actuator or instrument.

**⚠ WARNING**

Personal injury or property damage can occur from cover failure due to overpressure. Ensure that the housing vent opening is open and free of debris to prevent pressure buildup under the cover.

This unit vents the supply medium into the surrounding atmosphere. When installing this unit in a non-hazardous (non-classified) location in a confined area, with natural gas as the supply medium, you must remotely vent this unit to a safe location. Failure to do so could result in personal injury or property damage from fire or explosion, and area re-classification.

When installing this unit in a hazardous (classified) location remote venting of the unit may be required, depending upon the area classification, and as specified by the requirements of local, regional, and national codes, rules and regulations. Failure to do so when necessary could result in personal injury or property damage from fire or explosion, and area re-classification.

In addition to remote venting of the unit, ensure that all caps and covers are correctly installed. Failure to do so could result in personal injury or property damage from fire or explosion, and area re-classification.

3. If necessary, remove the plastic vent on the DVC6200 and install a pipe-away vent line using at least 12.7 mm (1/2-inch) diameter tubing. The vent line must be as short as possible with a minimum number of bends and elbows to prevent back pressure build-up.

Figure 17. Vent Connection

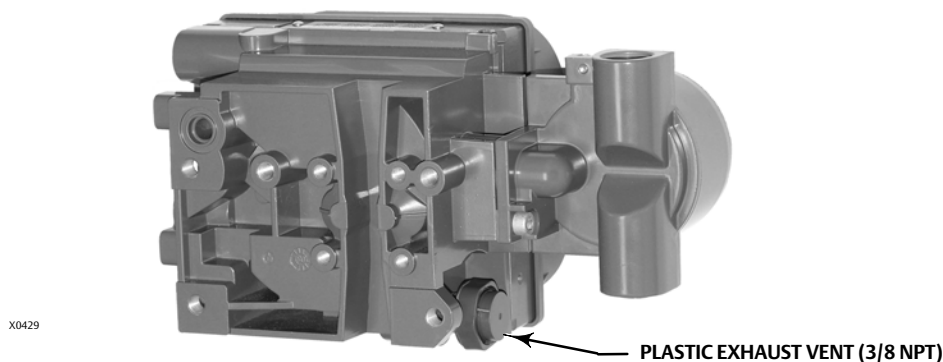

**⚠ WARNING**

To avoid personal injury or property damage resulting from bursting or parts, do not exceed maximum supply pressure.

Personal injury or property damage may result from fire or explosion if natural gas is used as the supply medium and appropriate preventive measures are not taken. Preventive measures may include, but are not limited to, one or more of the following: Remote venting of the unit, re-evaluating the hazardous area classification, ensuring adequate ventilation, and the removal of any ignition sources.

**Note**

The Natural Gas Certified, Single Seal device option simplifies conduit sealing requirements. Natural Gas Certified, Single Seal instruments can be identified by the natural gas approval label shown in figure 18. Read and follow all local, regional, and federal wiring requirements for natural gas installations. Contact your [Emerson Process Management sales office](#) for information on obtaining a Natural Gas Certified, Single Seal DVC6200 digital valve controller.

Figure 18. Label for Natural Gas Certified Terminal Box

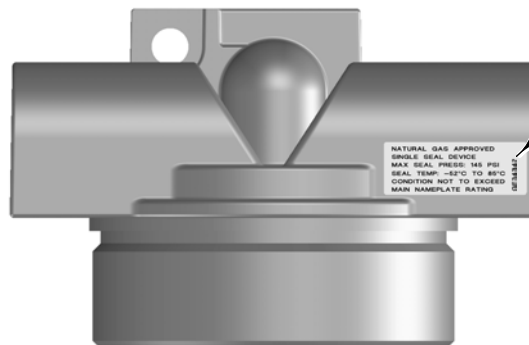
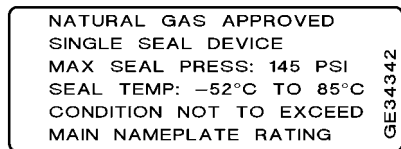

LABEL LOCATED  
ON TOP OF  
TERMINAL BOX

X0748

4. Connect the pneumatic supply line to the 1/4 NPT IN connection on the filter regulator.
5. Proceed to Step 3—Connect the Electrical Wires on page 23.



## Step 3—Connect the Electrical Wires

### **⚠ WARNING**

Select wiring and/or cable glands that are rated for the environment of use (such as hazardous area, ingress protection and temperature). Failure to use properly rated wiring and/or cable glands can result in personal injury or property damage from fire or explosion.

Wiring connections must be in accordance with local, regional, and national codes for any given hazardous area approval. Failure to follow the local, regional, and national codes could result in personal injury or property damage from fire or explosion.

To avoid personal injury resulting from electrical shock, do not exceed maximum input voltage specified on the product nameplate. If the input voltage specified differs, do not exceed the lowest specified maximum input voltage.

Personal injury or property damage caused by fire or explosion may occur if this connection is attempted in a potentially explosive atmosphere or in an area that has been classified as hazardous. Confirm that area classification and atmosphere conditions permit the safe removal of the terminal box cover before proceeding.

The valve may move in an unexpected direction when power is applied to the digital valve controller. To avoid personal injury and property damage caused by moving parts, keep hands, tools, and other objects away from the valve/actuator assembly when applying power to the instrument.

For FOUNDATION fieldbus™ or PROFIBUS PA devices proceed to page 24

For HART® devices proceed to page 26

## FOUNDATION fieldbus or PROFIBUS PA Devices

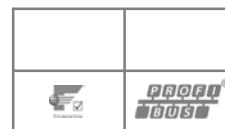

Refer to the [DVC6200f instruction manual](#) or the [DVC6200p instruction manual](#), available at [www.FIELDVUE.com](http://www.FIELDVUE.com) or from your local [Emerson Process Management sales office](#) for additional information.

The digital valve controller is normally powered over the bus from a power supply. Refer to the FOUNDATION fieldbus or PROFIBUS site planning guide, available from your Emerson Process Management sales office, for proper wire types, termination, length, grounding practices, etc.

### Note

To avoid the valve going to an unknown position when power is applied, the unit digital valve controller is shipped from the factory with the transducer block mode Out of Service.

Wire the digital valve controller as follows, refer to figure 19.

1. Remove the wiring terminal box cap.
2. Bring the field wiring into the terminal box. When applicable, install conduit using local and national electrical codes which apply to the application.
3. The instrument is not polarity sensitive. Connect one wire from the controller output to one of the LOOP screw terminals in the terminal box shown in figure 19. Connect the other wire from the controller output to the other LOOP screw terminal in the terminal box.

Figure 19. Loop Connections Terminal Box

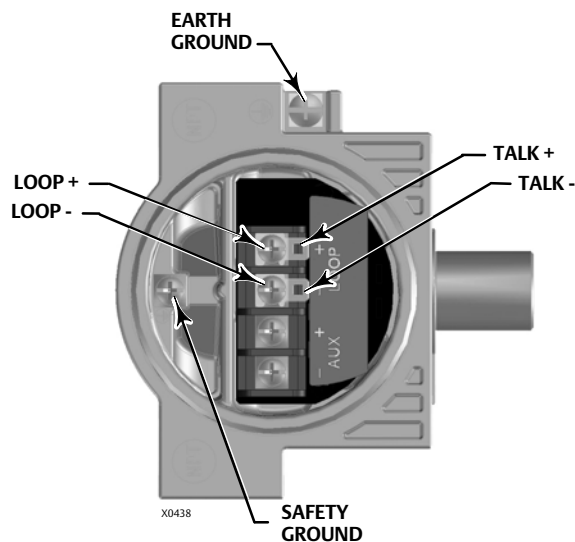

### ⚠ WARNING

Personal injury or property damage can result from the discharge of static electricity. Connect a 14 AWG (2.08 mm<sup>2</sup>) ground strap between the digital valve controller and earth ground when flammable or hazardous gases are present. Refer to national and local codes and standards for grounding requirements.



4. Make connections to the ground terminal(s) following national and local codes and plant standards. As shown in figure 19, two ground terminals are available for connecting a safety ground, earth ground, or drain wire. The safety ground terminal is electrically identical to the earth ground.
5. Replace and hand tighten the cover on the terminal box.
6. Write the valve tag number on the top and bottom of the paper commissioning tag, as shown in figure 20.

Figure 20. Paper Commissioning Tag

**COMMISSIONING TAG**

DEVICE ID  
005100XXXXFisherDVC-HMMS

TAG

TEAR HERE

DD\_Rev  Dev\_Type

DEV\_Rev

Function  FL  FC  SC

Block  FB Logic  FB Ctrl  Std Ctrl  SS

Diag  FD  AD  DI

FB Diag  Adv Diag  Perf Diag

005100XXXXFisherDVC-HMMS

TAG

**WRITE THE VALVE TAG NUMBER HERE**

XXXX = Device Type	HH = Hardware Rev	MM = MSP rev	S= SERIAL NUMBER
--------------------	-------------------	--------------	------------------

1889406-G

7. Remove the lower half of the paper commissioning tag and deliver it to the control system configurator. With the piece of paper, the control system configurator will be able to easily change the Device ID placeholder to the actual valve tag number.

**Note**

Alternatively, the valve tag number can be entered at the factory when specified at the time of order entry. When the valve tag number is electronically stored on the DVC6200, the control system will display the valve tag number instead of the Device ID. As a result, step 6 and 7 will not be required.

8. For Remote Mount applications, proceed to page 30. Otherwise proceed to Step 4—Configure the Digital Valve Controller on page 33.

	SIS

## HART Devices

Refer to the [DVC6200 HW1 instruction manual](#), the [DVC6200 HW2 instruction manual](#), or the [DVC6200 SIS instruction manual](#), available at [www.FIELDVUE.com](http://www.FIELDVUE.com) or from your local [Emerson Process Management sales office](#) for additional information.

The digital valve controller is normally powered by a control system output channel. Shielded cable will ensure proper operation in electrically noisy environments.

Wire the digital valve controller as follows, refer to figure 21:

1. Remove the wiring terminal box cap.
2. Bring the field wiring into the terminal box. When applicable, install conduit using local and national electrical codes which apply to the application.
3. Connect the control system output channel positive wire to the LOOP + screw terminal in the terminal box. Connect the control system output channel negative (or return) wire to the LOOP - screw terminal in the terminal box.

### **⚠ WARNING**

**Personal injury or property damage, caused by fire or explosion, can result from the discharge of static electricity. Connect a 14 AWG (2.08 mm<sup>2</sup>) ground strap between the digital valve controller and earth ground when flammable or hazardous gases are present. Refer to national and local codes and standards for grounding requirements.**

4. As shown in figure 21, two ground terminals are available for connecting a safety ground, earth ground, or drain wire. The safety ground is electrically identical to the earth ground. Make connections to these terminals following national and local codes and plant standards.

Figure 21. Loop and Talk Connections

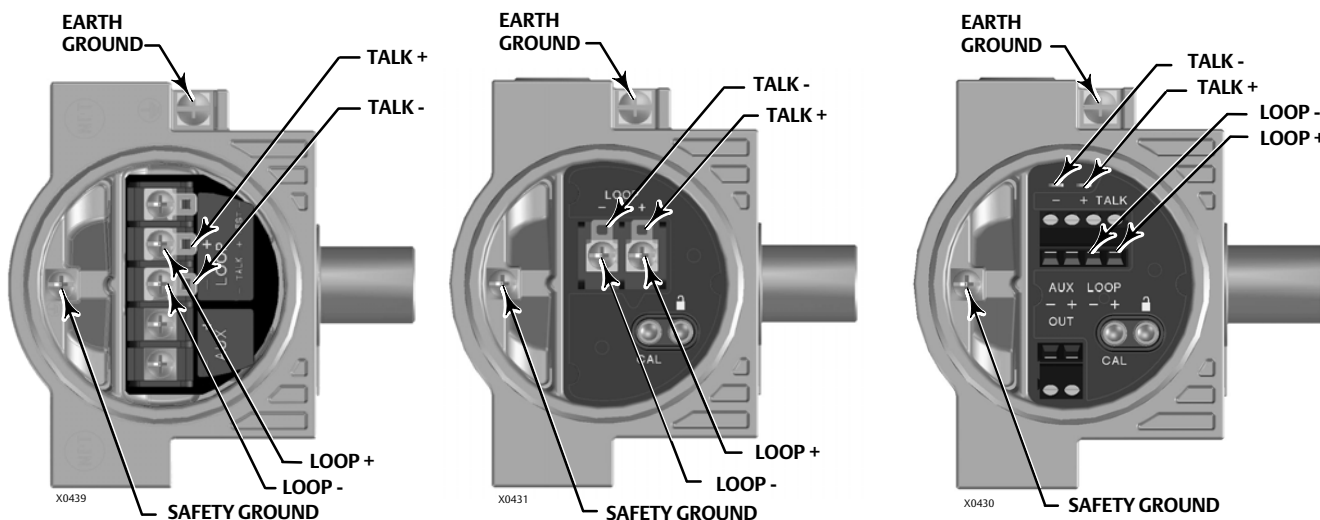

---

**Note**

Depending on the control system you are using, an HF340 HART filter may be needed to allow HART communication. The HART filter is a passive device that is inserted in field wiring from the HART loop. The filter is normally installed near the field wiring terminals of the control system I/O. Its purpose is to effectively isolate the control system output from modulated HART communication signals and raise the impedance of the control system to allow HART communication. For more information on the description and use of the HART filter, refer to the [HF340 HART filter instruction manual \(D102796X012\)](#). To determine if your system requires a HART filter refer to the [DVC6200 HW1 instruction manual](#), the [DVC6200 HW2 instruction manual](#), or the [DVC6200 SIS instruction manual](#), or contact your [Emerson Process Management sales office](#).

---

5. Replace and hand tighten the cover on the terminal box.
6. For applications that require a Position Transmitter or Discrete Switch (page 28), Remote Feedback Mounting (page 30), and/or THUM™ Adapter (page 32), proceed to the appropriate page. For DVC6200 SIS applications proceed to Special Instructions for Safety Instrumented Systems on page 35. Otherwise, proceed to Step 4—Configure the Digital Valve Controller on page 33.



## Position Transmitter or Discrete Switch

The DVC6200 HART communicating device has an optional output circuit that can be configured as a 4-20 mA position transmitter or a discrete switch. Configuration of the output circuit requires the proper DIP switch electrical setting on the main electronics board (figure 22) and also must be enabled with a user interface tool. The DIP switch electrical setting is preconfigured at the factory when ordered properly.

Figure 22. OUTPUT Connections and Transmitter / Switch Settings

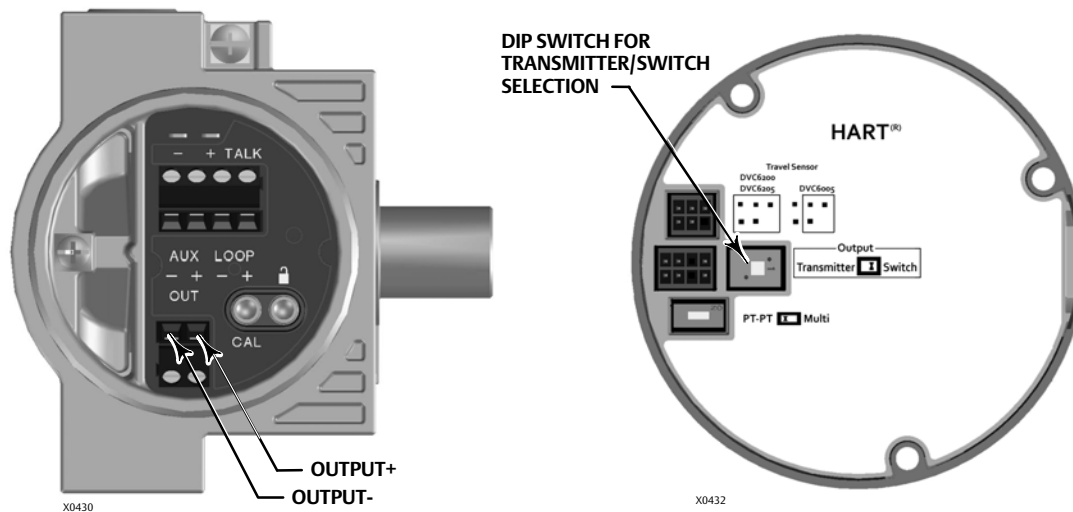

The position transmitter circuit derives its operating power from the control system input channel in the same manner as a 2-wire transmitter. The position transmitter circuit operates independently from the digital valve controller.

The discrete switch is a solid state circuit (1-amp maximum) which opens and closes based on a user configurable trip point. The trip point can be based on valve travel anywhere within the calibrated travel range, or based on a device alert. In order for the switch output to function, the digital valve controller must be powered. If power is lost, the switch will always go to the open state. The output circuit, whether operating as a transmitter or switch, is galvanically isolated from the position control loop circuit such that different ground references between the 2 circuits are allowed.

Wire the OUTPUT terminals as follows (refer to figure 23):

1. Route the field wiring into the terminal box through the conduit connection.
2. When applicable, install conduit using any local and national electrical codes that apply to the connection.
3. Connect the control system input channel positive wire to the OUT (+) terminal. Connect the control system input channel negative wire to the OUT (-) terminal.
4. Replace and hand tighten the cover on the terminal box.
5. For applications that require Remote Feedback Mounting (page 30) and/or a THUM Adapter (page 32), proceed to the appropriate page. For DVC6200 SIS applications proceed to Special Instructions for Safety Instrumented Systems on page 35. Otherwise, proceed to Step 4—Configure the Digital Valve Controller on page 33.

Figure 23. FIELDVUE DVC6200 with Position Transmitter or Discrete Switch, Field Wiring Schematic

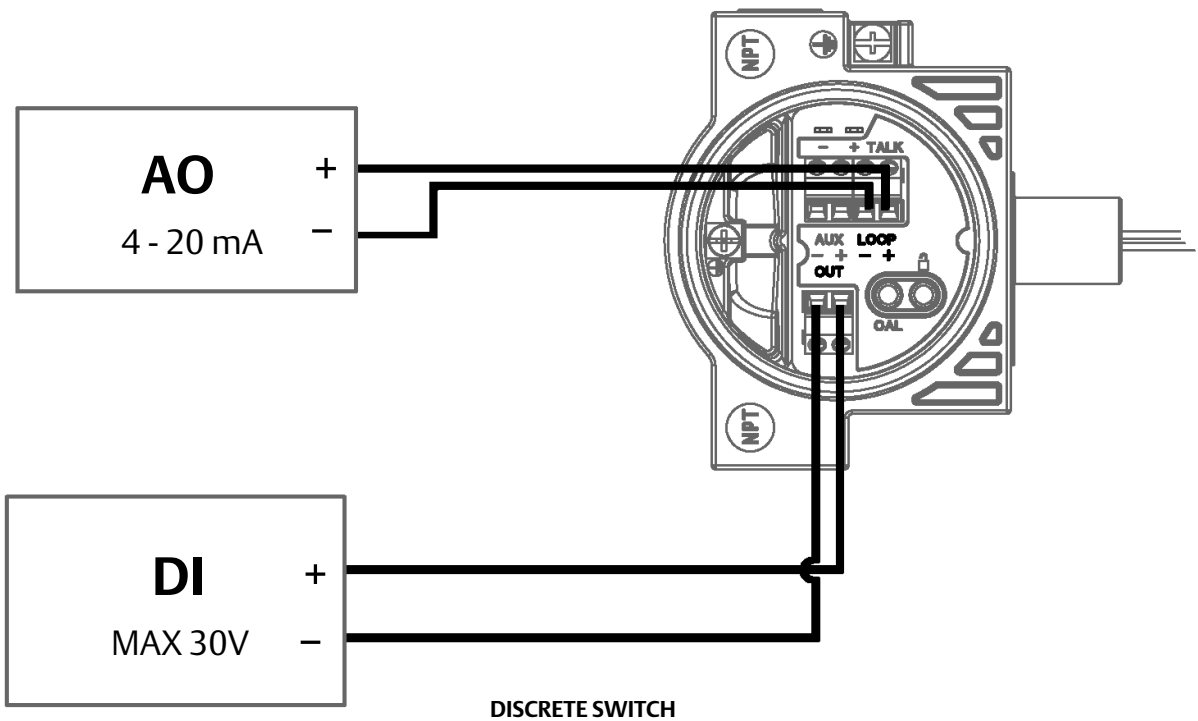
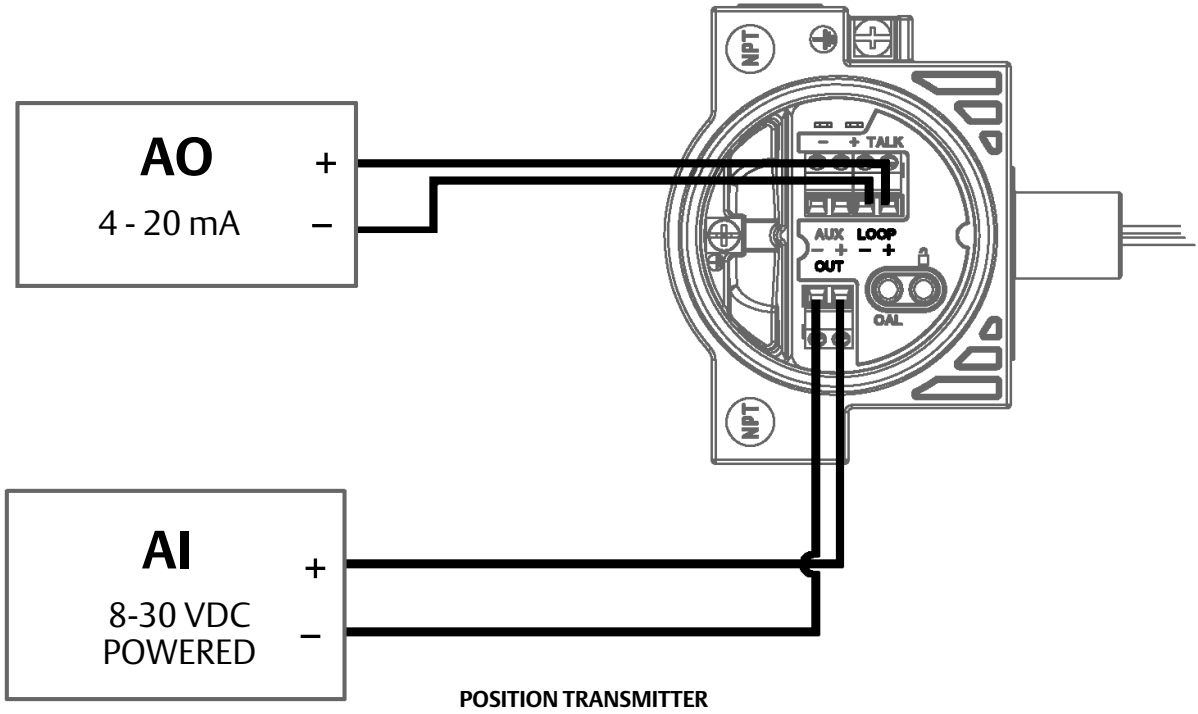



## Remote Mount Feedback Unit

The DVC6205 base unit is designed to receive a valve travel signal via the DVC6215 feedback unit.

### **⚠ WARNING**

**Do not place feedback wiring in the same conduit as other power or signal wiring.**

**Personal injury or property damage, caused by wiring failure, can result if the feedback wiring connecting the base unit with the remote feedback unit shares a conduit with any other power or signal wiring.**

### **Note**

4-conductor shielded cable, 18 to 22 AWG minimum wire size, in rigid or flexible metal conduit, is required for connection between base unit and feedback unit. Pneumatic tubing between base unit output connection and actuator has been tested to 91 meters (300 feet). At 15 meters (50 feet) there was no performance degradation. At 91 meters there was minimal pneumatic lag.

1. Remove the termination caps from both the DVC6215 feedback unit and DVC6205 base unit.
2. Install conduit between the feedback unit and the base unit following applicable local and national electrical codes.
3. Route the 4-conductor shielded cable through the conduit.
4. Connect each wire of the 4-conductor shielded cable between the corresponding terminals on the feedback unit and the base unit (refer to figure 24).

### **⚠ WARNING**

**The cable shield is typically not insulated. It is required that you insulate the cable shield prior to installation.**

**When connecting the cable shield in step 5 ensure that any exposed shielding does not contact the DVC6215 housing, as shown in figure 25. Failure to do so can result in ground loop issues.**

5. Connect the cable shield between terminal S on the feedback unit and terminal S on the base unit.

### **CAUTION**

**Failure to secure the cable wires in the support clips in step 6 can result in broken wires in applications with high levels of vibration.**

6. Secure the cable wires, using the support clips in the DVC6215 feedback unit (as shown in figure 25), to help prevent shifting and movement of the wires.
7. Replace and hand-tighten all covers.
8. For applications that require a THUM Adapter proceed to page 32. For DVC6200 SIS applications proceed to Special Instructions for Safety Instrumented Systems on page 35. Otherwise proceed to Step 4—Configure the Digital Valve Controller on page 33.

Figure 24. Terminal Details for Connecting the Base Unit and Feedback Unit for Remote-Mounted Digital Valve Controllers

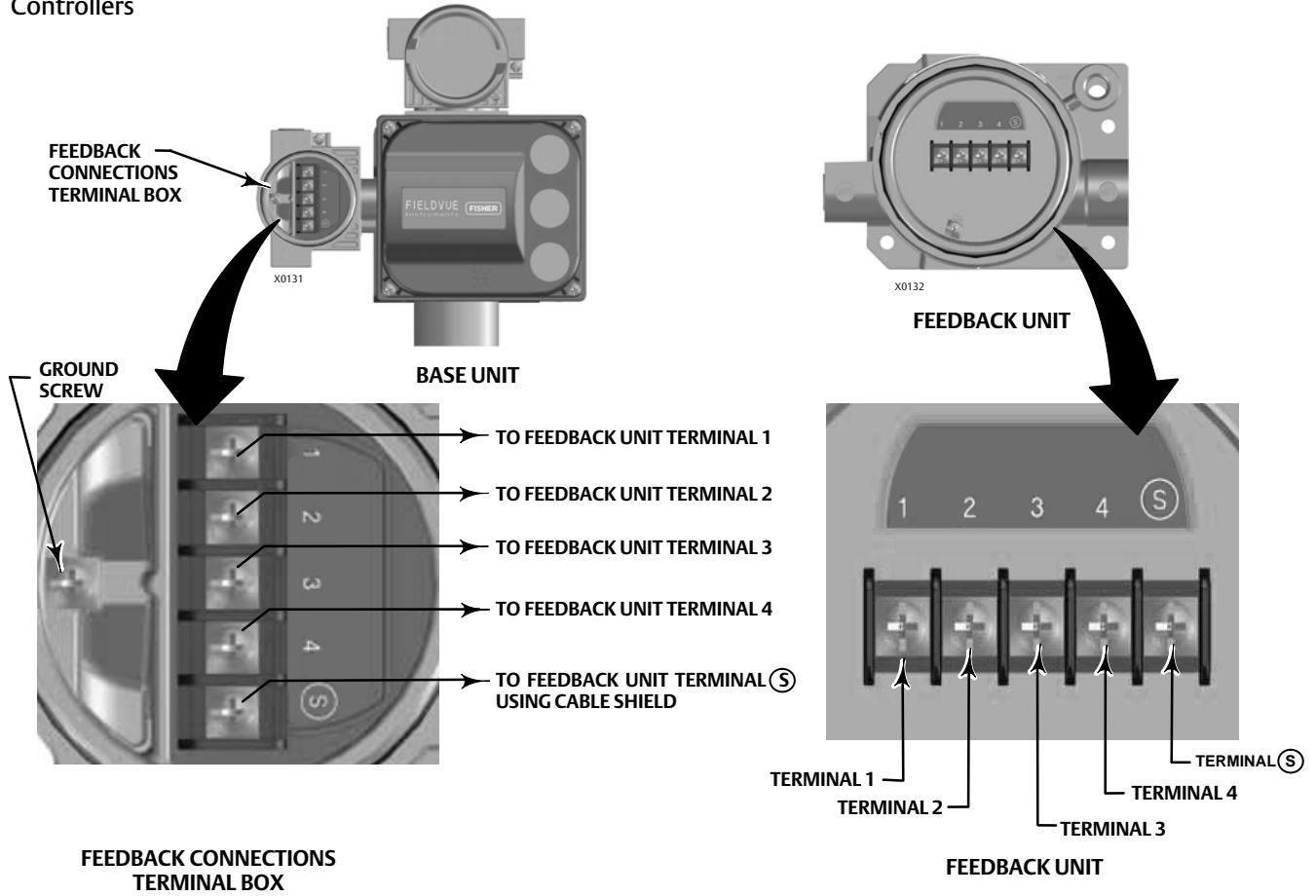
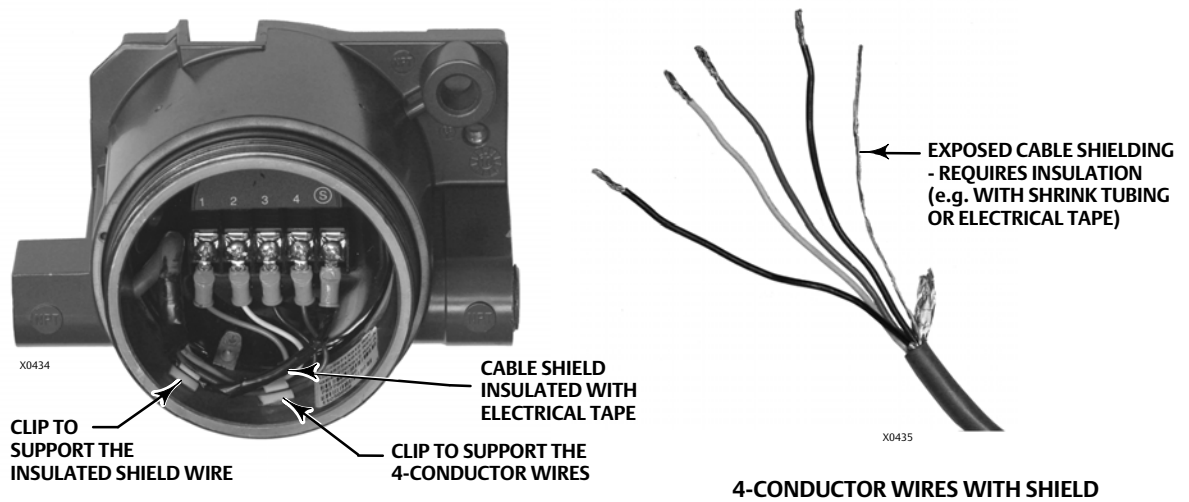

Figure 25. Wire Clips





## Smart Wireless THUM Adapter

Refer to the [Smart Wireless THUM Adapter quick installation guide \(00825-0100-4075\)](#) for additional information.

### Note

The recommended mounting orientation for the THUM Adapter is vertically up, as shown in figure 26, for optimal wireless communication range.

Figure 26. THUM Adapter Installed On DVC6200 Digital Valve Controller



X0433

1. Remove the DVC6200 terminal box plug from the top conduit entrance.
2. Thread the THUM Adapter into the top conduit entrance.
3. Using the wire splice included with the THUM Adapter (or other suitable wire splice), connect the wires as shown in figure 27 below.

Figure 27. Wiring the THUM Adapter

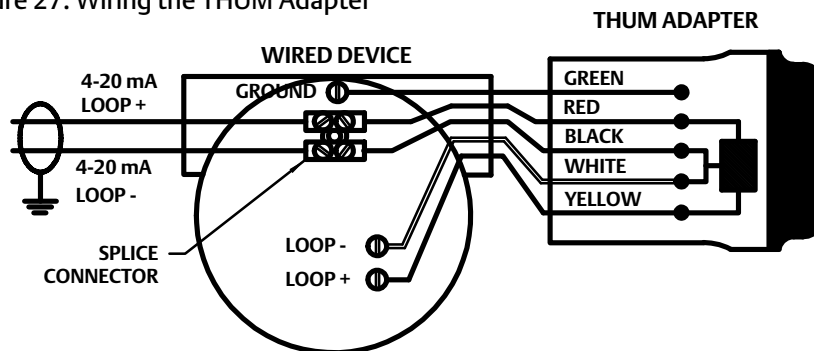

GG18677

4. Carefully coil the wires inside the terminal box.
5. Replace and hand tighten the cover on the terminal box.
6. Proceed to Step 4—Configure the Digital Valve Controller on page 33.





## Step 4—Configure the Digital Valve Controller

### ⚠ WARNING

- Select wiring and/or cable glands that are rated for the environment of use (such as hazardous area, ingress protection and temperature). Failure to use properly rated wiring and/or cable glands can result in personal injury or property damage from fire or explosion.
- Wiring connections must be in accordance with local, regional, and national codes for any given hazardous area approval. Failure to follow the local, regional, and national codes could result in personal injury or property damage from fire or explosion.
- To avoid personal injury resulting from electrical shock, do not exceed maximum input voltage specified on the product nameplate. If the input voltage specified differs, do not exceed the lowest specified maximum input voltage.
- Personal injury or property damage caused by fire or explosion may occur if this connection is attempted in a potentially explosive atmosphere or in an area that has been classified as hazardous. Confirm that area classification and atmosphere conditions permit the safe removal of the terminal box cover before proceeding.
- The valve may move in an unexpected direction when power is applied to the digital valve controller. To avoid personal injury and property damage caused by moving parts, keep hands, tools, and other objects away from the valve/actuator assembly when applying power to the instrument.
- While configuring the digital valve controller the valve may move, causing process fluid or pressure to be released. To avoid personal injury and property damage caused by the release of process fluid or pressure, isolate the valve from the process and equalize pressure on both sides of the valve or bleed off the process fluid.
- Changes to the instrument setup may cause changes in the output pressure or valve travel. Depending on the application, these changes may upset process control, which may result in personal injury or property damage.

### CAUTION

Before proceeding, check that all pressure connections, fasteners, and plugs are installed and tightened.

For remote mount installations, ensure that the Base Unit is wired to the Feedback Unit before providing electrical power. Failure to do so may cause the DVC6205 to go into “Pressure Control” mode if Pressure Fallback is configured. The unit can be returned to “Travel Control” mode using Detailed Configuration.

1. Install the latest version of the communication software on the user interface tool. This may include Device Descriptions (DD, EDD), ValveLink™ software, Device Type Manager (DTM), or GSD. Refer to table 1 below.

Contact your local Emerson Process Management sales office to ensure that you have the latest software version or for information on locating the necessary files.

Table 1. User Interface Tools and Software Available for Instrument Configuration and Calibration

	DVC6200 HART	DVC6200 SIS HART	DVC6200f FOUNDATION fieldbus	DVC6200p PROFIBUS PA
475 Field Communicator (DD)	☑	☑	☑	
AMS Device Manager (DD)	☑	☑	☑	
ValveLink Software	☑	☑	☑	
ValveLink Mobile Software	☑		☑	
Field Device Type Frame (DTM)	☑	☑	☑	
Siemens SIMATIC™ PDM Software (DD, GSD)				☑

2. Apply pneumatic supply pressure to the digital valve controller and adjust the supply pressure regulator according to the actuator requirements and limitations.
  3. Apply electrical power to the digital valve controller.
  4. Establish communication with the digital valve controller and commission the instrument as described in the host system documentation.
- 

**Note**

If the TALK terminals on the digital valve controller are to be used for communication, remove the terminal box cap to access the terminals.

---

5. Launch the user interface tool.
  6. Perform Device Setup to configure and calibrate the instrument on the control valve assembly.
  7. Enter any additional custom configuration items (optional).
- 

**Note**

On HART devices with the optional transmitter or switch option, you must enable and configure the output terminals. The configuration is disabled by default from the factory.

---

8. To enable the digital valve controller to follow set point, place the instrument In Service (HART devices) or place the transducer block in Auto (fieldbus and PROFIBUS devices).



## Special Instructions for Safety Instrumented Systems

DVC6200 SIS instruments are identified by an SIS label on the terminal box cover. Refer to the [Safety manual](#) for further information regarding the design, installation, and operation of the DVC6200 SIS product.

The following section illustrates typical installation scenarios for a DVC6200 SIS. The digital valve controller can be configured to trip on low current (de-energize to trip, DETT) or high current (energize to trip, ETT). See figure 28 for the DIP switch configuration of this action on the printed wiring board. This setting is preconfigured at the factory when ordered properly.

Figure 28. DIP Switch Location

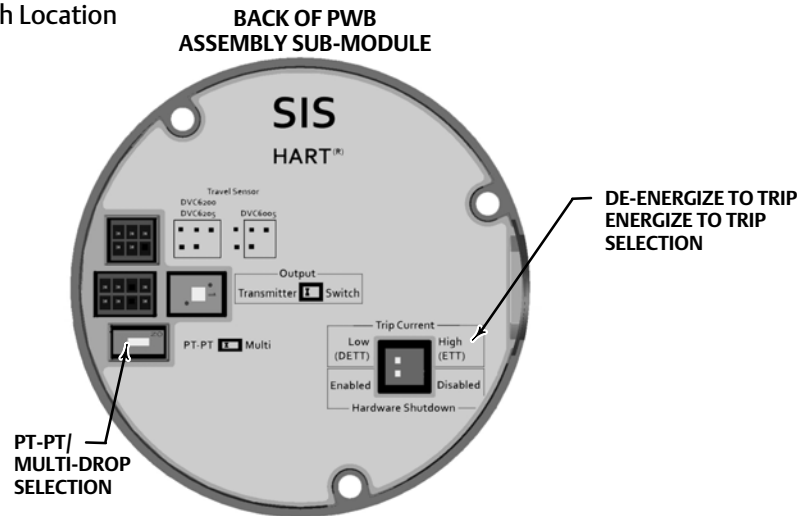

X0436

Table 2. DIP Switch Configuration<sup>(1)</sup>

Switch Label	Operational Mode	DIP Switch Position
PT-PT	4-20 mA Point-to-Point Loop	LEFT
Multi	24 VDC Multi-Drop Loop	RIGHT
Hardware Shutdown	Enabled	LEFT
Hardware Shutdown	Disabled	RIGHT
Trip Current Low (DETT)	De-energize to trip	LEFT
Trip Current High (ETT)	Energize to trip	RIGHT

1. Refer to figure 28 for switch location.

### Note

DVC6200 SIS instruments in PT-PT mode require the Hardware Shutdown Switch be Enabled for FMEDA failure rates to be valid for 4-20 mA operation.

### ⚠ WARNING

When Hardware Shutdown is enabled, the instrument will respond to a signal change regardless of instrument mode. The valve may move in an unexpected direction when power is applied to the digital valve controller. To avoid personal injury and property damage caused by moving parts, keep hands, tools, and other objects away from the valve/actuator assembly when applying power to the instrument.

An optional local control panel (LCP100), shown in figure 29, can be installed to provide manual operation of the DVC6200 SIS instrument. Refer to the [LCP100 instruction manual \(D103272X012\)](#) for further information.

---

**Note**

If the LCP100 is connected to a DVC6200 SIS in a zone 1 explosion-proof “d” environment, there must be a conduit seal installed between the DVC6200 SIS and the LCP100 in order to maintain the explosion-proof integrity of the DVC6200 SIS.

The LCP100 cannot be connected to a DVC6200 SIS that is part of a zone 0 or zone 1 intrinsically safe “i” installation.

---

Figure 29. LCP100 Connected to a DVC6200 SIS Instrument



X0248

---

For de-energize to trip DVC6200 SIS and de-energize to trip solenoid valve, proceed to page 37

For de-energize to trip DVC6200 SIS, no solenoid valve, proceed to page 39

For DVC6200 SIS for PST only and de-energize to trip solenoid valve, proceed to page 41

For solenoid valve health monitoring installations, proceed to page 42

## De-Energize to Trip (DETT) DVC6200 SIS and DETT Solenoid Valve

In a typical de-energize to trip application with a solenoid valve, the logic solver (or DCS) trip signal de-energizes the solenoid valve and also reduces the signal to the digital valve controller to 4 mA (or 0 VDC). This opens the solenoid valve vent and drives the digital valve controller to the no output pressure condition. As a result, the safety valve moves to its no-air, fail safe position.

Figure 30. FIELDVUE DVC6200 SIS and Solenoid Valve Powered Separately

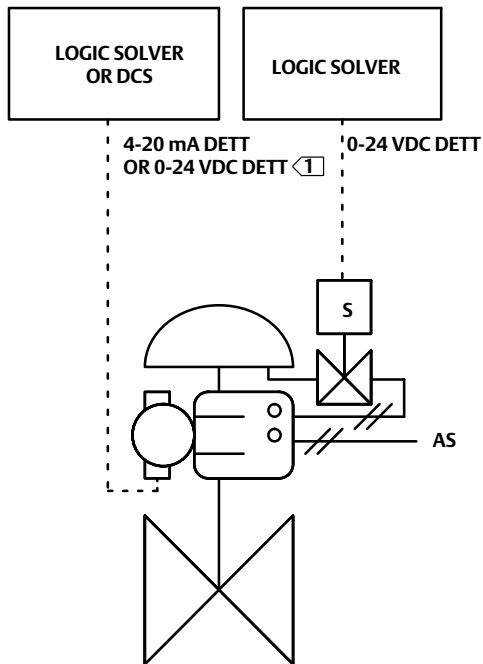

**1** AN LC340 LINE CONDITIONER IS REQUIRED FOR 0-24 VDC DETT  
E1455

Figure 31. FIELDVUE DVC6200 SIS and Solenoid Valve Powered Together

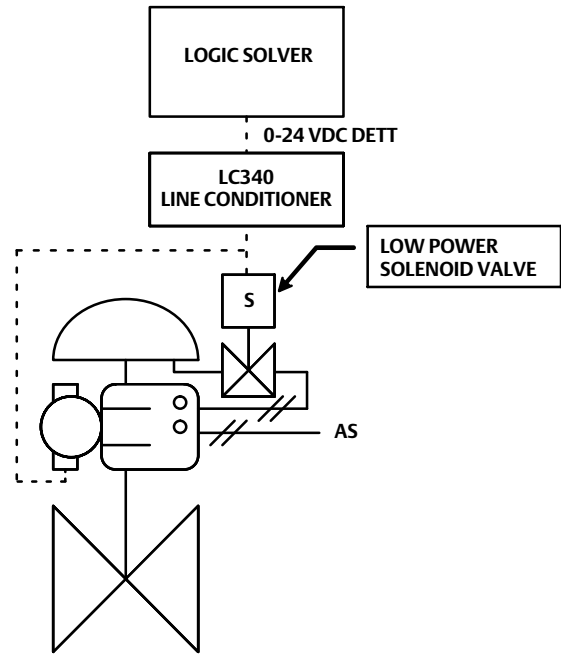

E1456

### Note

When using an ASCO™ low-power solenoid valve, model EF8316G303 or EF8316G304 (or an equivalent low-power solenoid valve) a separate external air supply for the pilot is required. Ensure that the solenoid valve's "selection gasket" is in the "external position". The pilot pressure must be at least 15 psig higher than the solenoid valve line pressure. For more information, refer to the ASCO catalog or contact your [Emerson Process Management sales office](#).

1. Install the solenoid valve on the actuator casing or actuator yoke.
2. Install at least 10 mm (3/8-inch) diameter tubing such that the solenoid valve is in the pneumatic path between the DVC6200 SIS output and the actuator input.

3. If the DVC6200 SIS and solenoid valve are powered separately:
  - Connect the logic solver output card +/- terminals to the corresponding solenoid valve +/- wires.
  - Connect the logic solver (or DCS) output card +/- terminals to the corresponding DVC6200 SIS LOOP +/- terminals.

**Note**

For the digital valve controller to operate with a 4-20 mA control signal the DIP switch must be in the point-to-point loop position, as shown in table 2. The control mode must be set to analog. This is set at the factory when ordered properly.

4. If the DVC6200 SIS and solenoid valve are powered together:
  - Install an LC340 line conditioner to allow HART communication over the segment. Refer to the [LC340 instruction manual \(D102797X012\)](#) for more information.
  - Connect the logic solver output card +/- terminals to the corresponding LC340 SYS +/- terminals.
  - Connect the digital valve controller LOOP +/- terminals to the corresponding LC340 FLD +/- terminals.
  - Connect the solenoid valve +/- wires to the corresponding LC340 FLD +/- terminals.

**Note**

For the digital valve controller to operate with a 0-24 VDC voltage control signal the DIP switches must be in the “Multi” position and the “Hardware Shutdown Disabled” position, as shown in figure 28 and table 2. The control mode must also be set to digital with a user interface tool. These are set at the factory when ordered properly.

Ensure that the LC340 Line Conditioner voltage drop, the solenoid valve engagement voltage (at maximum temperature), and the wiring voltage drop do not exceed the logic solver maximum output voltage. The line conditioner introduces an approximate 2.0 volt drop in the SIS system wiring with a 50 mA load. An ASCO EF8316 solenoid valve requires 18.4 V and 42 mA to trip. The digital valve controller draws approximately 8 mA. Based on these conditions, table 3 lists the maximum loop wire resistance permitted for various logic solver output voltages.

Table 3. Maximum Loop Wire Resistance per Logic Solver Output Voltage<sup>(1)</sup>

Logic Solver Output Voltage (VDC)	Maximum Loop Wire Resistance (Ohms)	Maximum Wire Length - meters (feet) <sup>(2)</sup>			
		22 AWG	20 AWG	18 AWG	16 AWG
24.00	32.0	290 (952)	435.6 (1429)	725.7 (2381)	967.7 (3175)
23.75	27.0	245 (804)	367.3 (1205)	612.3 (2009)	816.6 (2679)
23.50	22.0	200 (655)	299 (982)	499.0 (1637)	665.4 (2183)
23.25	17.0	154 (506)	231 (759)	385.6 (1265)	514.2 (1687)
23.00	12.0	109 (357)	163 (536)	272 (893)	363 (1190)
22.75	7.0	63.4 (208)	95.4 (313)	159 (521)	212 (694)
22.50	2.0	18 (60)	27 (89)	45.4 (149)	60.4 (198)

1. Maximums in this table assume a line conditioner and a solenoid that requires a minimum of 20.4 V and 42 mA to engage.  
 2. Wire length includes both wires in a twisted pair.

5. Proceed to Step 4—Configure the Digital Valve Controller on page 33.

## De-Energize to Trip (DETT) DVC6200 SIS, no Solenoid Valve

In a typical de-energize to trip application without a solenoid valve, the logic solver trip signal de-energizes the digital valve controller to 4 mA (or 0 VDC). This drives the digital valve controller to the no output pressure condition. As a result, the safety valve moves to its no-air, fail safe position.

Figure 32. FIELDVUE DVC6200 SIS Powered with 4-20 mA

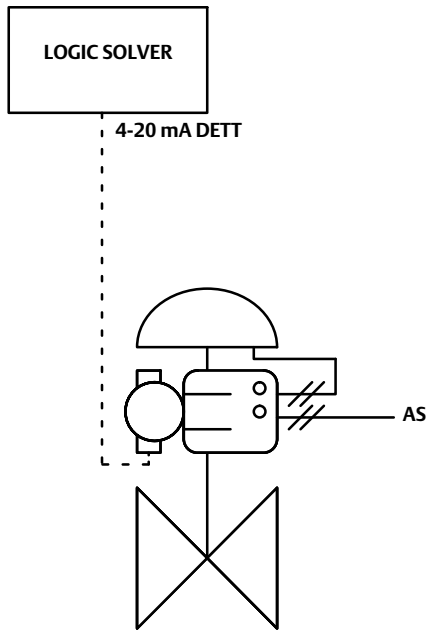

E1457

Figure 33. FIELDVUE DVC6200 SIS Powered with 0-24 VDC

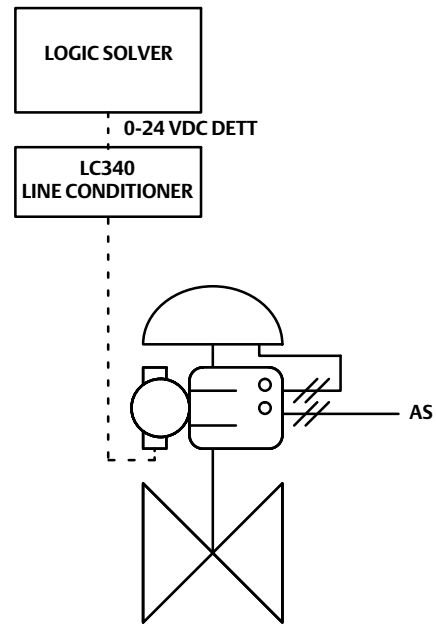

E1458

1. If the DVC6200 SIS is powered with 4-20 mA, connect the logic solver output card +/- terminals to the corresponding DVC6200 SIS LOOP +/- terminals.

### Note

For the digital valve controller to operate with a 4-20 mA control signal the DIP switch must be in the point-to-point loop position, as shown in table 2. The control mode must be set to analog. This is set at the factory when ordered properly.

2. If the DVC6200 SIS and solenoid valve are powered together:

- Install an LC340 line conditioner to allow HART communication over the segment. Refer to the [LC340 instruction manual](#) for more information.
- Connect the logic solver output card +/- terminals to the corresponding LC340 SYS +/- terminals.
- Connect the digital valve controller LOOP +/- terminals to the corresponding LC340 FLD +/- terminals.

---

**Note**

For the digital valve controller to operate with a 0-24 VDC voltage control signal the DIP switches must be in the “Multi” position and the “Hardware Shutdown Disabled” position, as shown in figure 28 and table 2. The control mode must also be set to digital with a user interface tool. These are set at the factory when ordered properly.

---

3. Proceed to Step 4—Configure the Digital Valve Controller on page 33.



## DVC6200 SIS for PST only and De-Energize to Trip (DETT) Solenoid Valve

In this application, the logic solver trip signal de-energizes the solenoid valve, which opens the solenoid vent valve. The DVC6200 SIS is configured as energize to trip (ETT) and uses a reverse acting relay (Relay B) to drive the digital valve controller to the no output pressure condition. The energize to trip option provides maximum actuator pressure at minimum control signal (4 mA). Therefore, loss of the control signal will not cause the safety valve to trip. The safety valve moves to its no-air, fail safe position when the logic solver (or DCS) sets the current to the digital valve controller to 20 mA. Partial stroke testing occurs at minimum control signal (4 mA).

Figure 34. FIELDVUE DVC6200 SIS and Solenoid Valve Powered Separately

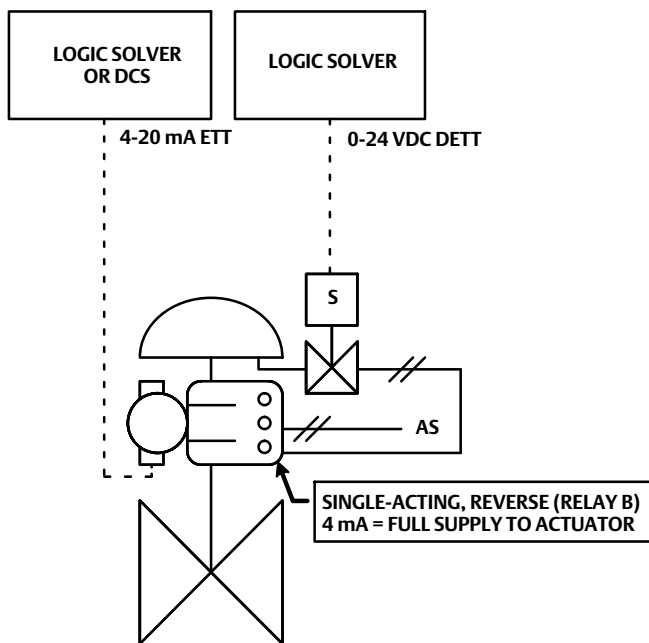

E1459

1. Install the solenoid valve on the actuator casing or actuator yoke.
2. Install at least 10 mm (3/8-inch) diameter tubing such that the solenoid valve is in the pneumatic path between the DVC6200 SIS output and the actuator input.
3. Connect the logic solver output card +/- terminals to the corresponding solenoid valve +/- wires.
4. Connect the logic solver (or DCS) output card +/- terminals to the corresponding DVC6200 SIS LOOP +/- terminals.
5. Proceed to Step 4—Configure the Digital Valve Controller on page 33.

## Solenoid Valve Health Monitoring

If a solenoid valve is installed between the DVC6200 SIS pressure output and the actuator, the control valve assembly can be configured to verify the operation of the solenoid valve. This applies to single-acting actuator applications only. The “unused” output port of the DVC6200 SIS is tubed such that the pressure downstream of the solenoid valve is measured. When the solenoid valve is pulsed, the DVC6200 SIS senses the momentary pressure drop across the solenoid valve.

Figure 35. Tubing for Solenoid Valve Health Monitoring, De-Energize to Trip DVC6200 SIS

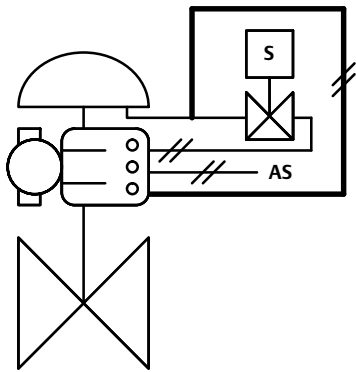

E1460

Figure 36. Tubing for Solenoid Valve Health Monitoring, Energize to Trip DVC6200 SIS

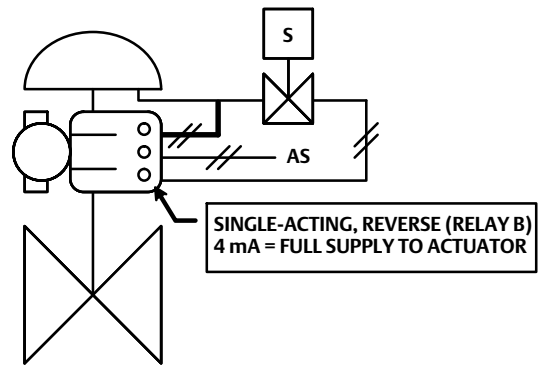

E1461

1. For DETT applications (figure 35):
  - Install at least 10 mm (3/8-inch) diameter tubing between output B (bottom port) of the DVC6200 SIS output and the tubing segment between the solenoid valve and safety valve actuator.
2. For ETT DVC6200 SIS applications (figure 36):
  - Install at least 10 mm (3/8-inch) diameter tubing between output A (top port) of the DVC6200 SIS output and the tubing segment between the solenoid valve and safety valve actuator.
3. Proceed to Step 4—Configure the Digital Valve Controller on page 33.



## Hazardous Area Approvals and Special Instructions for “Safe Use” and Installations in Hazardous Locations

Certain nameplates may carry more than one approval, and each approval may have unique installation/wiring requirements and/or conditions of “safe use”. These special instructions for “safe use” are in addition to, and may override, the standard installation procedures. Special instructions are listed by approval type.

---

### Note

This information supplements the nameplate markings affixed to the product.

Always refer to the nameplate itself to identify the appropriate certification. Contact your [Emerson Process Management sales office](#) for approval/certification information not listed here.

Approval information is for both aluminum and stainless steel constructions.

---

### **⚠ WARNING**

**Failure to follow these conditions of “safe use” could result in personal injury or property damage from fire or explosion, or area re-classification.**

---

For CSA Approvals    proceed to page 44

For FM Approvals    proceed to page 51

For ATEX Approvals    proceed to page 58

For IECEx Approvals    proceed to page 65

## CSA

### Ordinary Locations Approval

Complies with general electrical safety CAN/CSA-C22.2 No. 61010-1-2004  
SELV, conduit connected, Enclosure Type 4X, IP66, Installation Category I, Pollution Degree 4

#### **DVC6200 Series (HART HW1, FOUNDATION fieldbus, PROFIBUS)**

Rated Input 9-30 VDC, 4-20 mA  
-52°C to + 80°C Ambient

#### **DVC6205 (HART HW1, FOUNDATION fieldbus, PROFIBUS) DVC6215 Remote Mount**

Rated Input 9-30 VDC, 4-20 mA  
Outputs 0-9.6 VDC, 0-3.5 mA  
-52°C to + 80°C Ambient

Rated Input 10 VDC max, 3.5 mA max  
-52 to 125°C Ambient

### Explosion-proof and Dust Ignition-proof

#### **DVC6200 and DVC6205 Series (HART HW1 & HW2, SIS, FOUNDATION FIELDBUS, PROFIBUS)**

Class I, Division 1, Groups B,C,D ; Class I, Division 2, Groups A,B,C,D

Class II, Division 1, Groups E,F,G ; Class II, Division 2, Groups F,G

Class III, Division 1

Ex d IIC

Ex nC IIC

Type 4X, IP66

Single Seal Device (HART HW2 and SIS pending)

Rated input 30 Vmax, 20 mA

- 52°C < Ambient < + 80°C

Max inlet pressure 10 bar (145 psig) (air or natural gas)

Temperature Code: T6 (Tamb ≤ 75°C), T5 (Tamb ≤ 80°C)

#### **DVC6215 Remote Mount**

Class I, Division 1, Groups A,B,C,D ; Class I, Division 2, Groups A,B,C,D

Class II, Division 1, Groups E,F,G ; Class II, Division 2, Groups F,G

Class III

Ex d IIC

Ex nA IIC

Type 4X, IP66

Rated input 30 Vmax, 20 mA

- 52°C < Ambient < + 125°C

Temperature Code: T6 (Tamb ≤ 75°C), T5 (Tamb ≤ 90°C), T4 (Tamb ≤ 125°C)

## Intrinsically Safe

**Class I, Division 1, Groups A,B,C,D**

**Class II, Division 1, Groups E,F,G**

**Class III, Division 1**

**Ex ia IIC**

**Type 4X, IP66**

**Single Seal Device** (HART HW2 and SIS pending)

Rated input 30 V DC max, 20 mA

- 52 °C < Ambient < + 80 °C (-52 °C to 125 °C for DVC6215)

Max inlet pressure 10 bar (145 psig) (air or natural gas)

Intrinsically safe when connected per installation drawing GE42818, as shown in the following figures

<b>DVC6200 HW1</b> .....	figure 37 and 42
<b>DVC6200 HW2 and DVC6200 SIS</b> .....	figure 38 and 42
<b>DVC6205, DVC6205 SIS, and DVC6215 Remote Mount</b> .....	figure 39 and 42
<b>DVC6200f and DVC6200p</b> .....	figure 40 and 42
<b>DVC6205f, DVC6205p, and DVC6215 Remote Mount</b> .....	figure 41 and 42

Figure 37. CSA Loop Schematic—FIELDVUE DVC6200 HW1

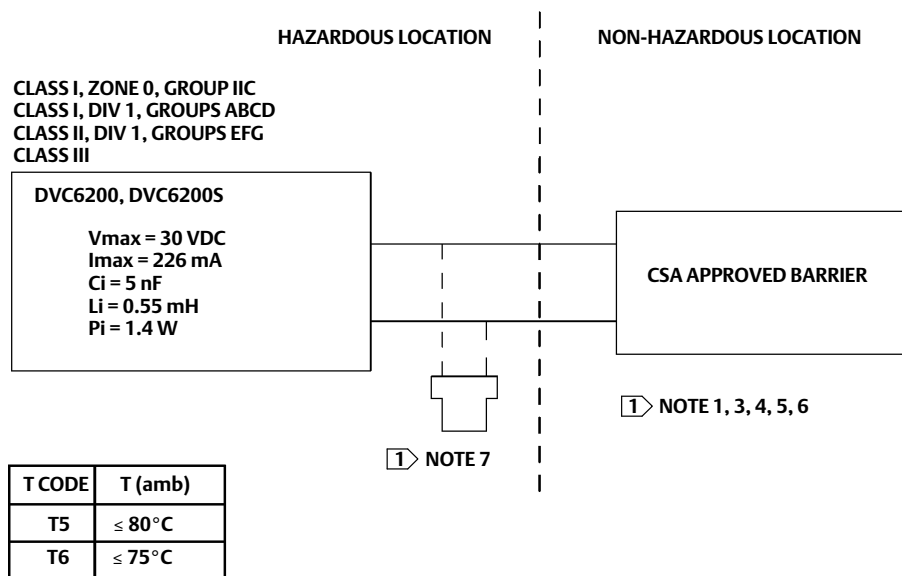

SEE NOTES IN FIGURE 42

GE42818 sheet 2, Rev. F

Figure 38. CSA Loop Schematics—FIELDVUE DVC6200 HW2 and DVC6200 SIS

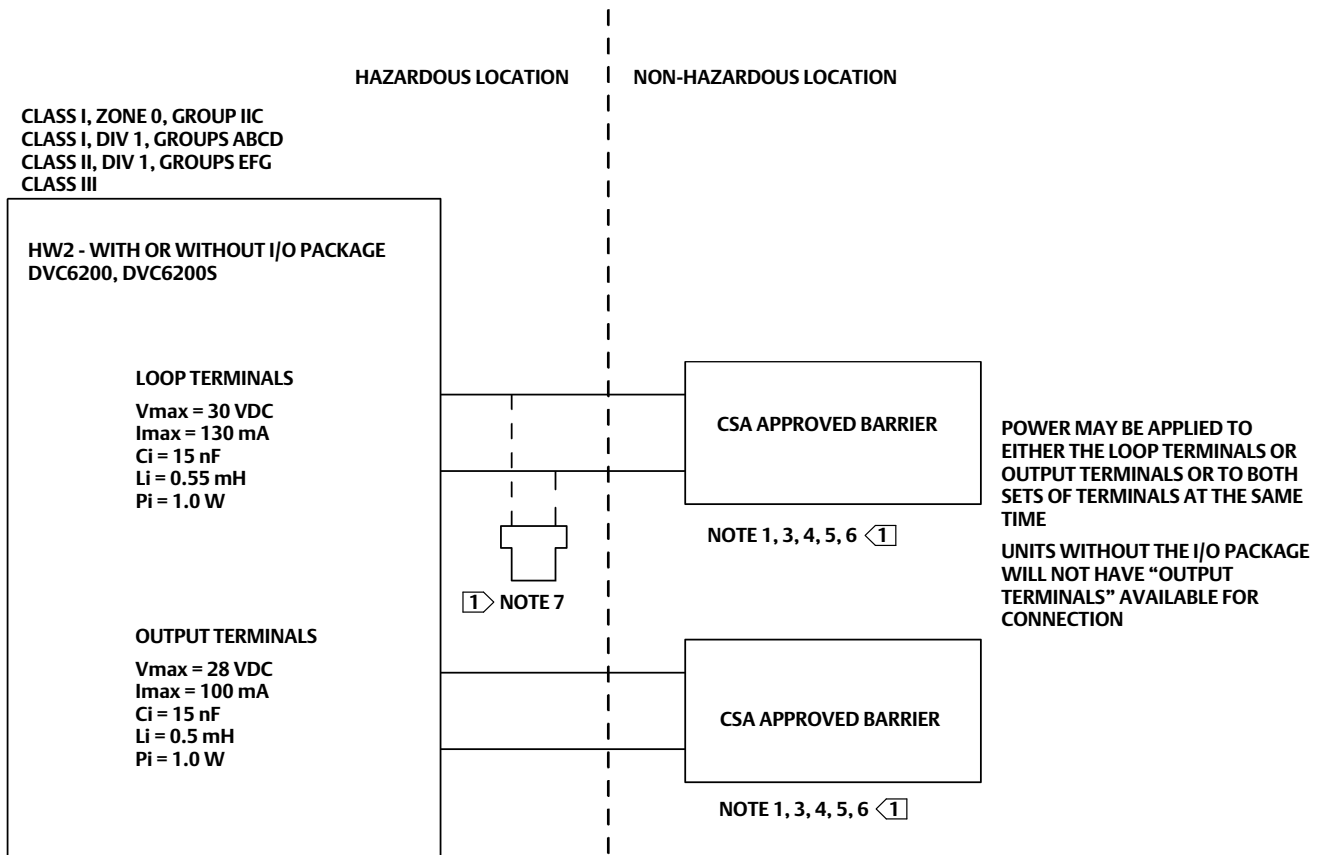

	WITH I/O PACKAGE	WITHOUT I/O PACKAGE
T CODE	T (amb)	T (amb)
T5	≤ 80°C	≤ 80°C
T6	≤ 61°C	≤ 74°C

SEE NOTES IN FIGURE 42

Figure 39. CSA Loop Schematics FIELDVUE DVC6205, DVC6205 SIS, and DVC6215

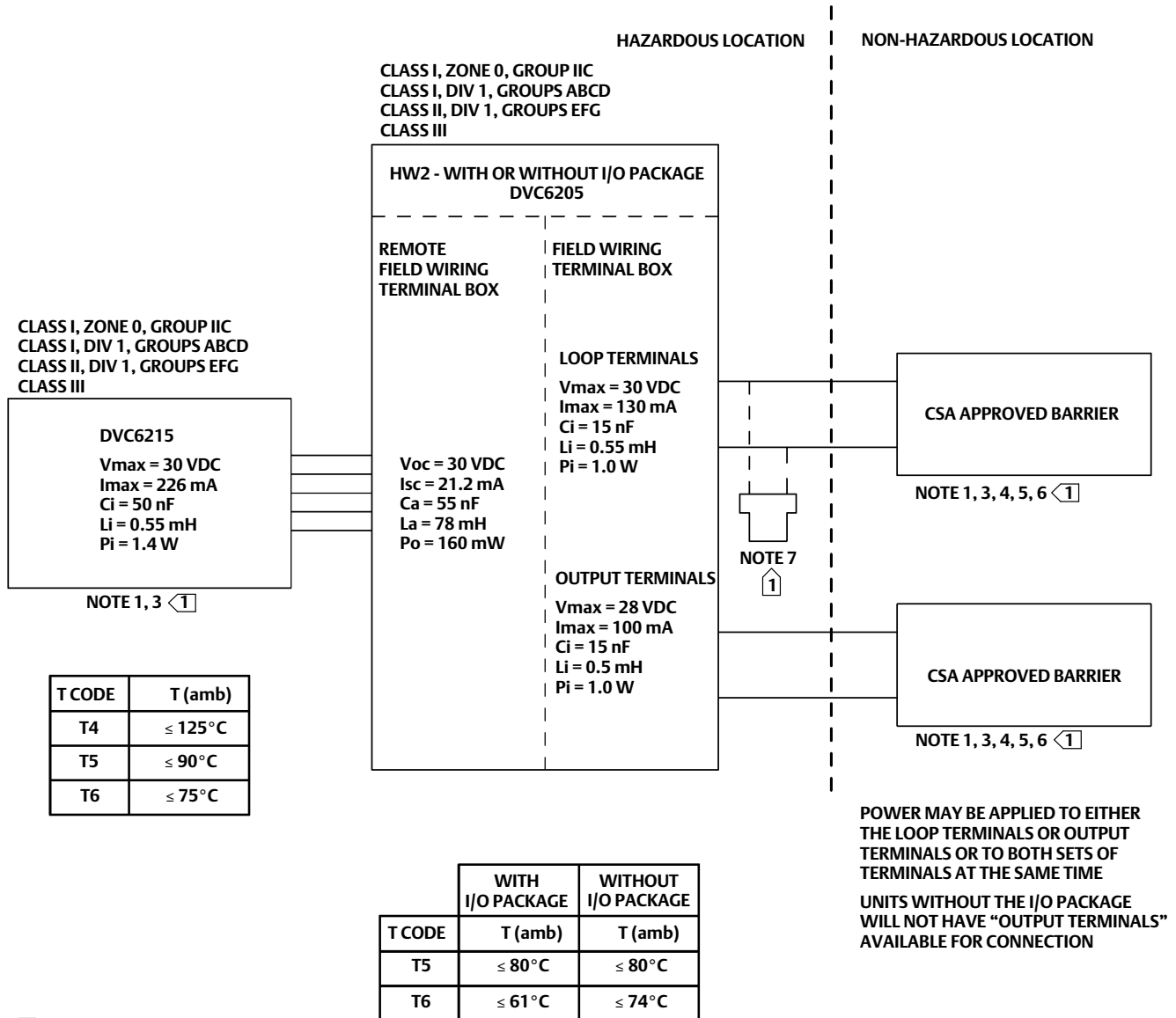

SEE NOTES IN FIGURE 42

GE42818 Sheet 12, Rev. C

Figure 40. CSA Loop Schematics—FIELDVUE DVC6200f and DVC6200p

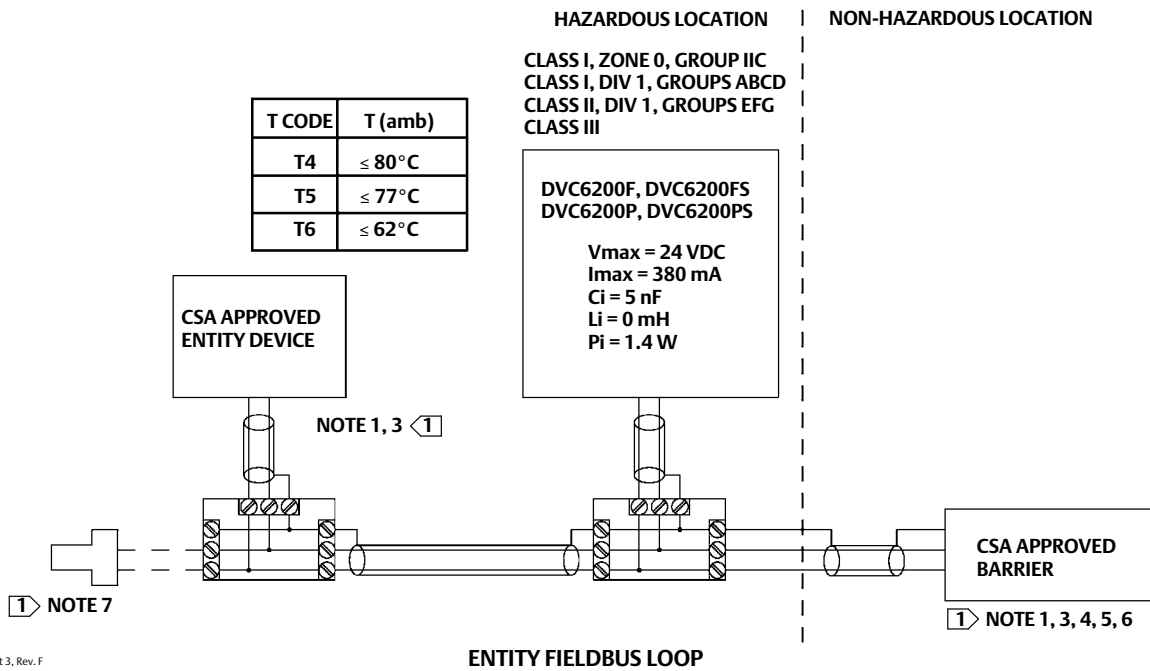

GE42818 Sheet 3, Rev. F

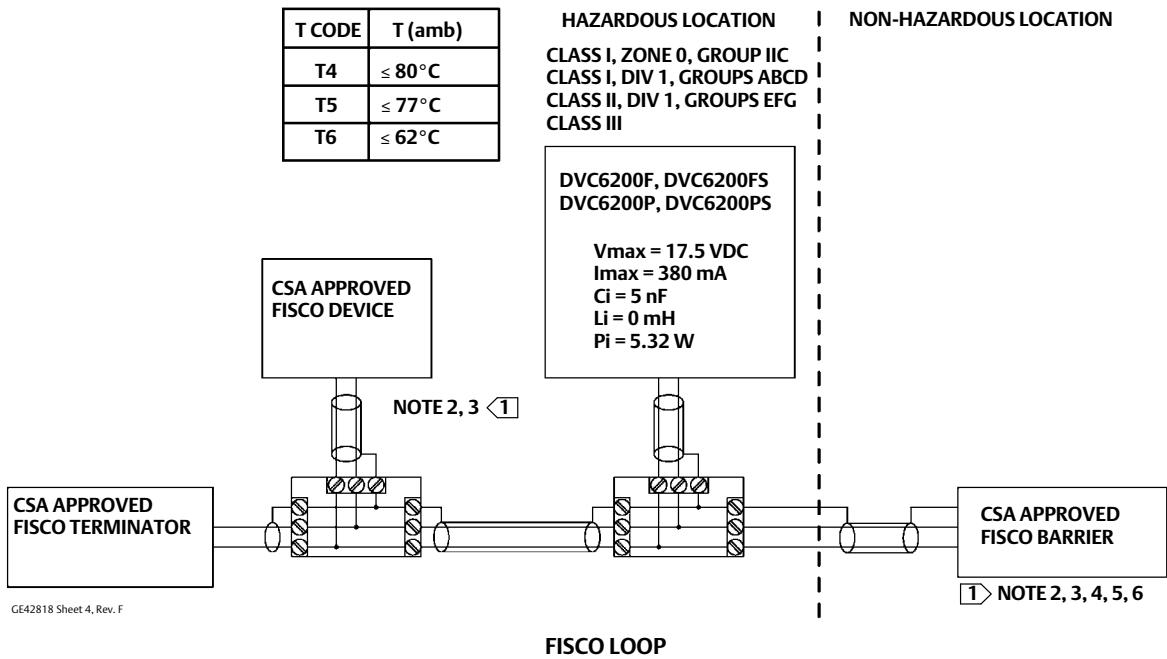

GE42818 Sheet 4, Rev. F

SEE NOTES IN FIGURE 42



Figure 41. CSA Loop Schematics FIELDVUE DVC6205f, DVC6205p, and DVC6215

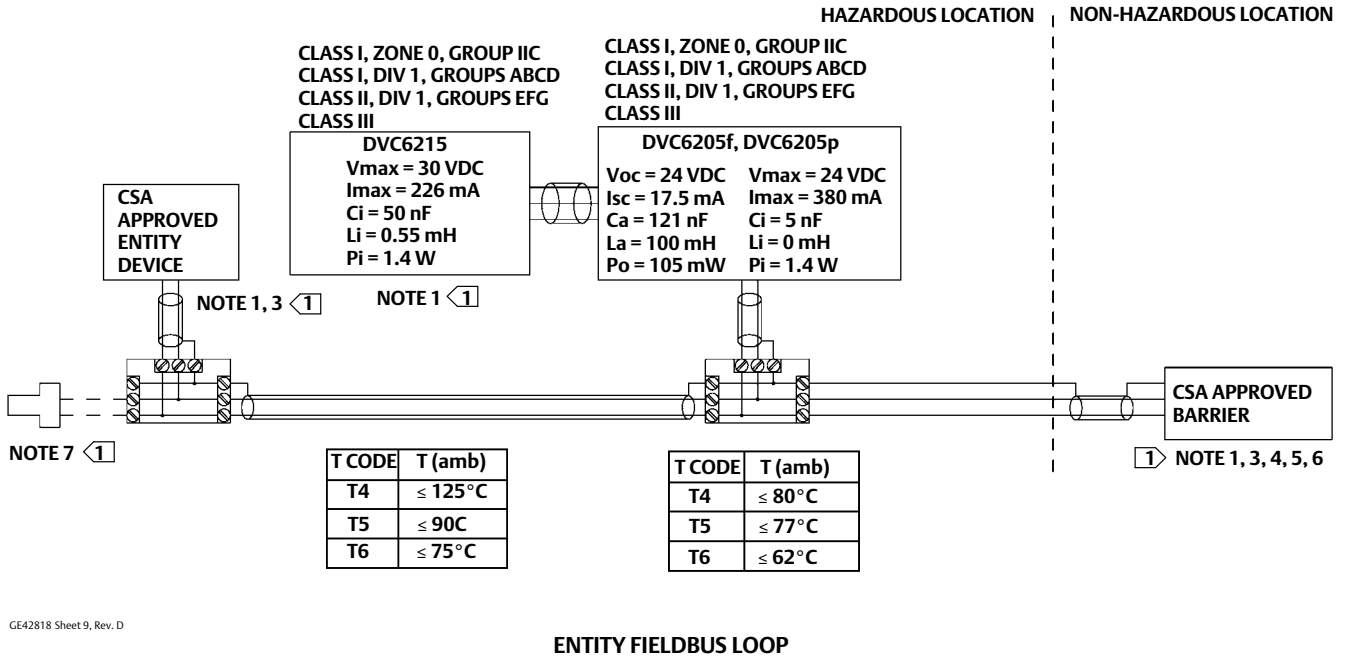

GE42818 Sheet 9, Rev. D

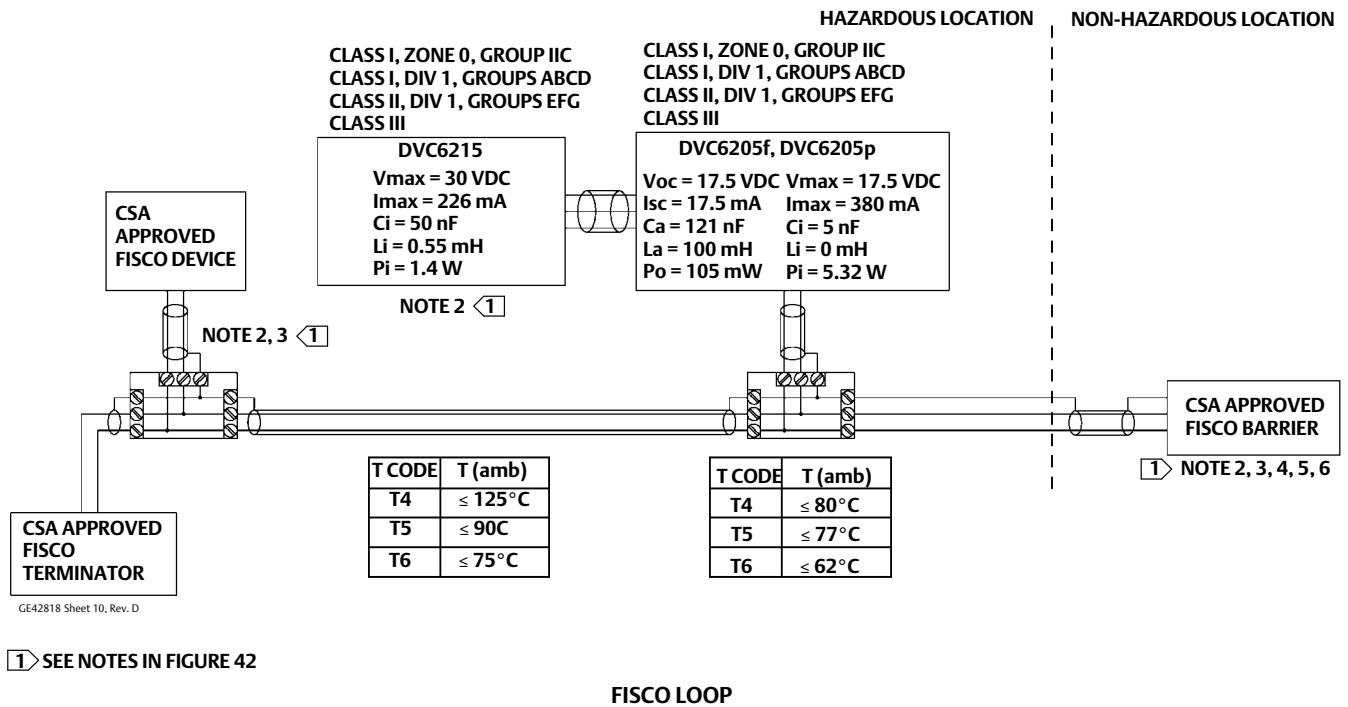

GE42818 Sheet 10, Rev. D

1 SEE NOTES IN FIGURE 42

Figure 42. Notes for CSA Loop Schematics

① THE ENTITY CONCEPT ALLOWS INTERCONNECTION OF INTRINSICALLY SAFE APPARATUS TO ASSOCIATED APPARATUS NOT SPECIFICALLY EXAMINED IN SUCH COMBINATION. THE CRITERIA FOR INTERCONNECTION IS THAT THE VOLTAGE ( $V_{max}$  or  $U_i$ ), THE CURRENT ( $I_{max}$  or  $I_i$ ), AND THE POWER ( $P_{max}$  or  $P_i$ ) OF THE INTRINSICALLY SAFE APPARATUS MUST BE EQUAL TO OR GREATER THAN THE VOLTAGE ( $V_{oc}$  or  $U_o$ ), AND THE CURRENT ( $I_{sc}$  or  $I_o$ ), AND THE POWER ( $P_o$ ) DEFINED BY THE ASSOCIATED APPARATUS. IN ADDITION, THE SUM OF THE MAX UNPROTECTED CAPACITANCE ( $C_i$ ) AND MAX UNPROTECTED INDUCTANCE ( $L_i$ ), INCLUDING THE INTERCONNECTING CABLING CAPACITANCE ( $C_{cable}$ ) AND CABLING INDUCTANCE ( $L_{cable}$ ) MUST BE LESS THAN THE ALLOWABLE CAPACITANCE ( $C_a$ ) AND INDUCTANCE ( $L_a$ ) DEFINED BY THE ASSOCIATED APPARATUS. IF THE ABOVE CRITERIA IS MET, THEN THE COMBINATION MAY BE CONNECTED.

$$V_{max} \text{ or } U_i \geq V_{oc} \text{ or } U_o \quad I_{max} \text{ or } I_i \geq I_{sc} \text{ or } I_o \quad P_{max} \text{ or } P_i \geq P_o \quad C_i + C_{cable} \leq C_a \quad L_i + L_{cable} \leq L_a$$

② THE FISCO CONCEPT ALLOWS INTERCONNECTION OF INTRINSICALLY SAFE APPARATUS TO ASSOCIATED APPARATUS NOT SPECIFICALLY EXAMINED IN SUCH COMBINATION. THE CRITERIA FOR THE INTERCONNECTION IS THAT THE VOLTAGE ( $V_{max}$  or  $U_i$ ), CURRENT ( $I_{max}$  or  $I_i$ ), AND POWER ( $P_{max}$  or  $P_i$ ), WHICH AN INTRINSICALLY SAFE APPARATUS CAN RECEIVE AND REMAIN INTRINSICALLY SAFE, CONSIDERING FAULTS, MUST BE EQUAL TO OR GREATER THAN THE VOLTAGE ( $V_{oc}$  or  $U_o$ ), CURRENT ( $I_{sc}$  or  $I_o$ ), AND POWER ( $P_o$ ) LEVELS WHICH CAN BE DELIVERED BY THE ASSOCIATED APPARATUS, CONSIDERING FAULTS AND APPLICABLE FACTORS. IN ADDITION THE MAXIMUM UNPROTECTED CAPACITANCE ( $C_i$ ) AND INDUCTANCE ( $L_i$ ) OF EACH APPARATUS (OTHER THAN THE TERMINATION) CONNECTED TO THE FIELD BUS MUST BE LESS THAN OR EQUAL TO 5 nF AND 10  $\mu$ H RESPECTIVELY.

IN EACH SEGMENT ONLY ONE ACTIVE DEVICE, NORMALLY THE ASSOCIATED APPARATUS, IS ALLOWED TO PROVIDE THE NECESSARY ENERGY FOR THE FIELD BUS SYSTEM. THE VOLTAGE ( $U_o$  or  $V_{oc}$  or  $V_t$ ) OF THE ASSOCIATED APPARATUS HAS TO BE LIMITED TO THE RANGE OF 9 V TO 17.5 VDC. ALL OTHER EQUIPMENT CONNECTED TO THE BUS CABLE HAS TO BE PASSIVE, MEANING THAT THEY ARE NOT ALLOWED TO PROVIDE ENERGY TO THE SYSTEM, EXCEPT FOR A LEAKAGE CURRENT OF 50  $\mu$ A FOR EACH CONNECTED DEVICE. SEPARATELY POWERED EQUIPMENT NEEDS A GALVANIC ISOLATION TO ASSURE THAT THE INTRINSICALLY SAFE FIELD BUS CIRCUIT REMAINS PASSIVE.

THE CABLE USED TO CONNECT THE DEVICES NEEDS TO HAVE THE PARAMETERS IN THE FOLLOWING RANGE:

LOOP RESISTANCE R': 15 TO 150 ohms/km

INDUCTANCE PER UNIT LENGTH L: 0.4 TO 1 mH/km

CAPACITANCE PER UNIT LENGTH C': 80 TO 200 nF/km

$C' = C' \text{ LINE/LINE} + 0.5' \text{ LINE/SCREEN}$ , IF BOTH LINES ARE FLOATING OR

$C' = C' \text{ LINE/LINE} + C' \text{ LINE/SCREEN}$ , IF THE SCREEN IS CONNECTED TO ONE LINE.

LENGTH OF SPLICE: < 1 m (T-BOX MUST ONLY CONTAIN TERMINAL CONNECTIONS WITH NO ENERGY STORAGE CAPABILITY)

LENGTH OF SPUR CABLE: < 30 M

LENGTH OF TRUNK CABLE: < 1 km

AT EACH END OF THE TRUNK CABLE AN APPROVED INFALLIBLE TERMINATION WITH THE FOLLOWING PARAMETERS IS SUITABLE:

$R = 90$  TO  $100$  ohms AND  $C = 0$  TO  $2.2$   $\mu$ F

NOTE, A BUILT-IN TERMINATOR IS INCLUDED IN THE FIELD SIDE AND A SELECTABLE TERMINATOR IS AVAILABLE ON THE HOST SIDE.

THE NUMBER OF PASSIVE DEVICES CONNECTED TO THE BUS SEGMENT IS NOT LIMITED IN THE FISCO CONCEPT FOR INTRINSICALLY SAFE REASONS. IF THE ABOVE RULES ARE RESPECTED, UP TO A TOTAL LENGTH OF 1000 m (SUM OF THE LENGTH OF THE TRUNK CABLE AND ALL SPUR CABLES), THE INDUCTANCE AND CAPACITANCE OF THE CABLE WILL NOT IMPAIR THE INTRINSIC SAFETY OF THE INSTALLATION.

③ INSTALLATION MUST BE IN ACCORDANCE WITH THE CANADIAN ELECTRICAL CODE (CEC) AND ANSI/ISA RP12.6.

④ MAXIMUM SAFE AREA VOLTAGE SHOULD NOT EXCEED 250  $V_{rms}$ .

⑤ RESISTANCE BETWEEN INTRINSICALLY SAFE GROUND AND EARTH GROUND MUST BE LESS THAN ONE OHM

⑥ LOOPS MUST BE CONNECTED ACCORDING TO THE BARRIER MANUFACTURER'S INSTRUCTIONS.

⑦ IF HAND-HELD COMMUNICATOR OR MULTIPLEXER IS USED, IT MUST BE CSA APPROVED WITH ENTITY PARAMETERS AND INSTALLED PER THE MANUFACTURER'S CONTROL DRAWINGS.

## FM

### Explosion-proof, Dust-Ignition proof, Non-Incendive, Suitable for Use

#### DVC6200 and DVC6205 Series (HART HW1 & HW2, SIS, FOUNDATION FIELDBUS, PROFIBUS)

XP: Class I, Division 1, Groups B,C,D  
DIP: Class II, III, Division 1, Groups E,F,G  
NI: Class I, Division 2, Groups A,B,C,D  
S: Class II, III, Division 2, Groups F,G  
T5 Ta = 80°C, T6 Ta = 75°C  
Type 4X, IP66

#### DVC6215 Remote Mount

XP: Class I, Division 1, Groups A,B,C,D  
DIP: Class II, III, Division 1, Groups E,F,G  
NI: Class I, Division 2, Groups A,B,C,D  
S: Class II, III, Division 2, Groups F,G  
Ta = 125°C, T5 Ta = 90°C, T6 Ta = 75°C  
Type 4X, IP66

### Intrinsically Safe

#### IS Class I, II, III, Division 1, Groups A,B,C,D,E,F,G

Type 4X, IP66

Intrinsically safe when connected per control drawing GE42819, as shown in the following figures

<b>DVC6200 HW1</b> .....	figure 43 and 48
<b>DVC6200 HW2 and DVC6200 SIS</b> .....	figure 44 and 48
<b>DVC6205, DVC6205 SIS, and DVC6215 Remote Mount</b> .....	figure 45 and 48
<b>DVC6200f and DVC6200p</b> .....	figure 46 and 48
<b>DVC6205f, DVC6205p, and DVC6215 Remote Mount</b> .....	figure 47 and 48

### Special Conditions of Safe Use

- When product is used with natural gas as the pneumatic medium, the maximum working pressure of the natural gas supply shall be limited to 10 bar (145 psi).
- When product is used with natural gas as the pneumatic medium the product shall not be permitted in a Class I, Division 2, Group A, B, C, D location without the proper venting installation per the manufacturer's instruction manual.
- The apparatus enclosure contains aluminum and is considered to constitute a potential risk of ignition by impact or friction. Care must be taken into account during installation and use to prevent impact or friction.
- Part of the enclosure is constructed from plastic. To prevent the risk of electrostatic sparking the plastic surface should only be cleaned with a damp cloth.

Figure 43. FM Loop Schematic—FIELDVUE DVC6200 HW1

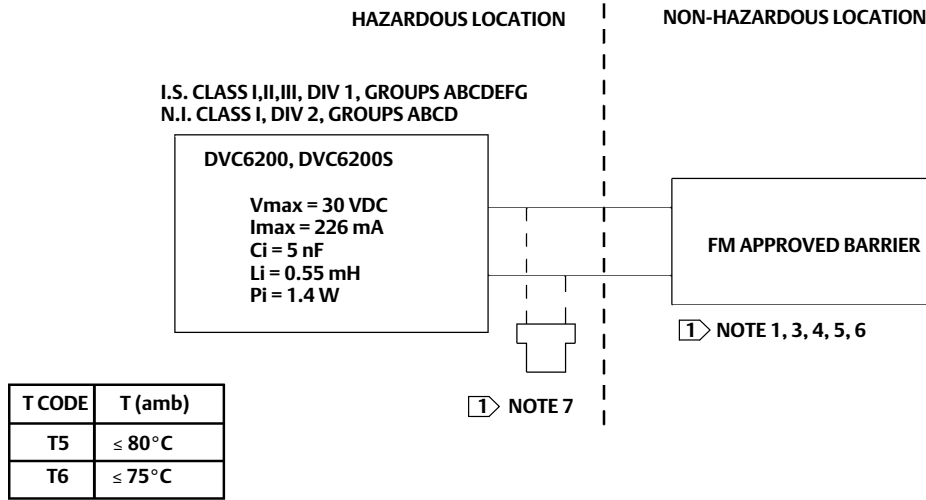

SEE NOTES IN FIGURE 48

GE42819 sheet 2, Rev. D

Figure 44. FM Loop Schematics—FIELDVUE DVC6200 HW2 and DVC6200 SIS

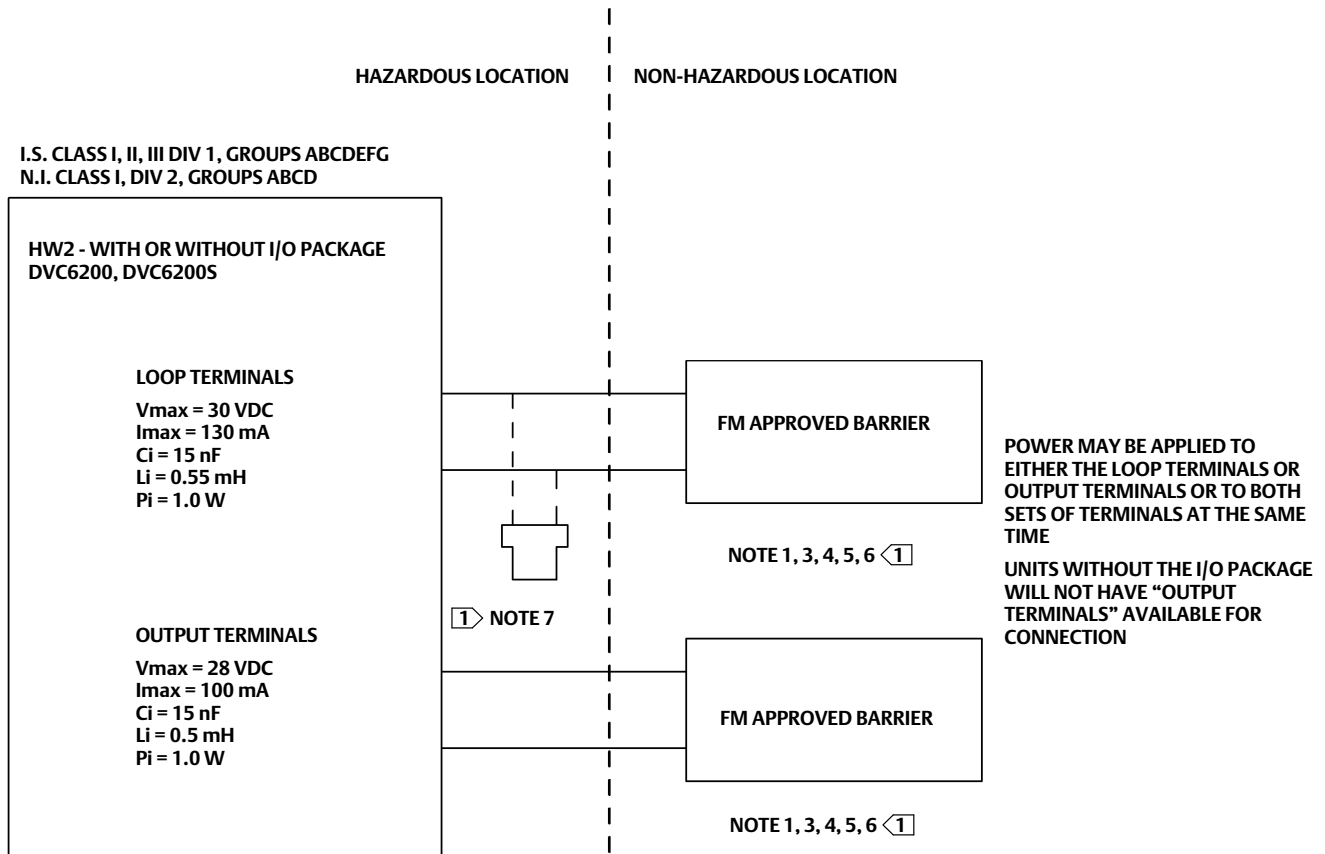

	WITH I/O PACKAGE	WITHOUT I/O PACKAGE
T CODE	T (amb)	T (amb)
T5	≤ 80°C	≤ 80°C
T6	≤ 61°C	≤ 74°C

SEE NOTES IN FIGURE 48

GE42819 Sheet 11, Rev. A

Figure 45. FM Loop Schematics—FIELDVUE DVC6205, DVC6205 SIS, and DVC6215

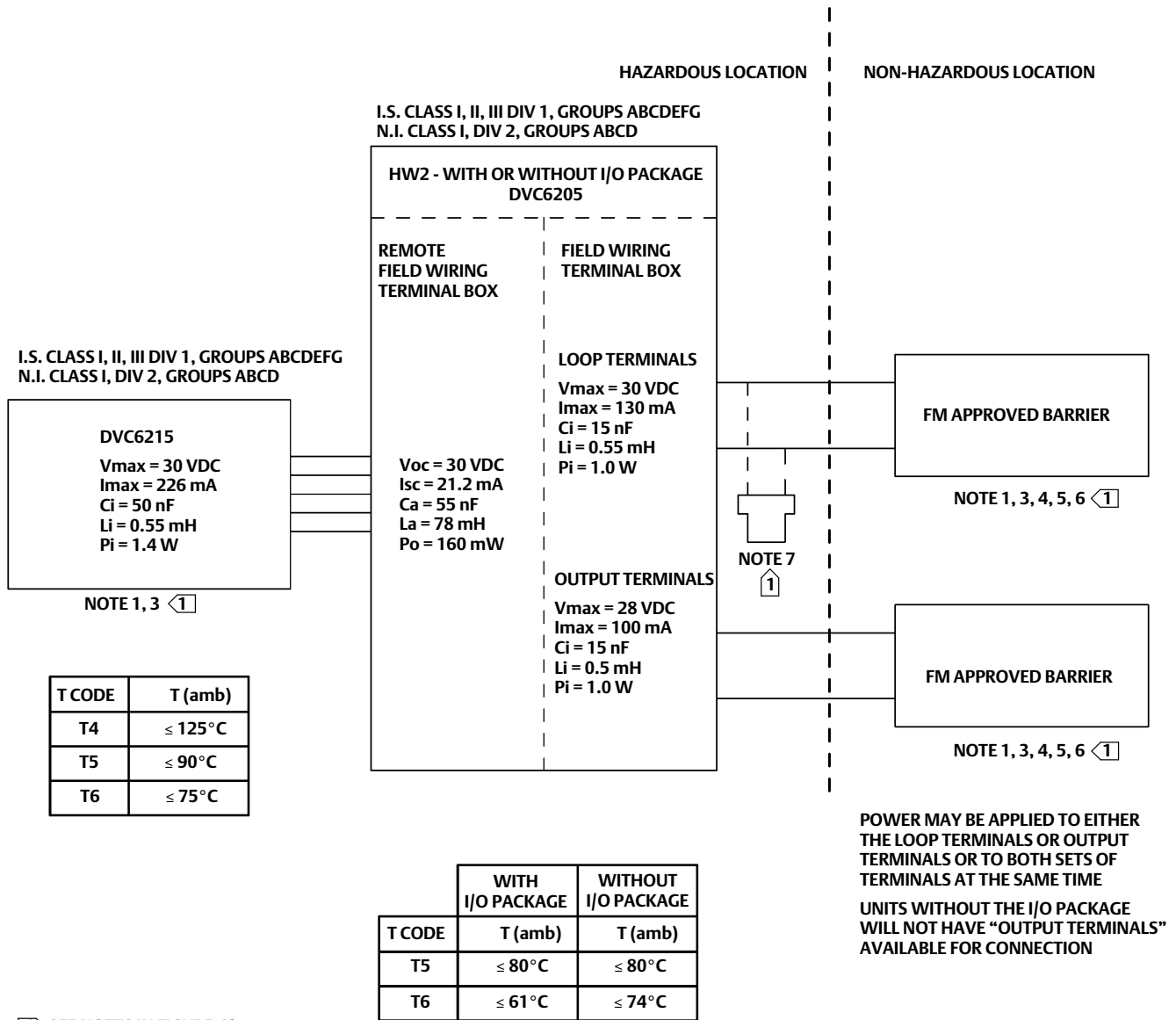
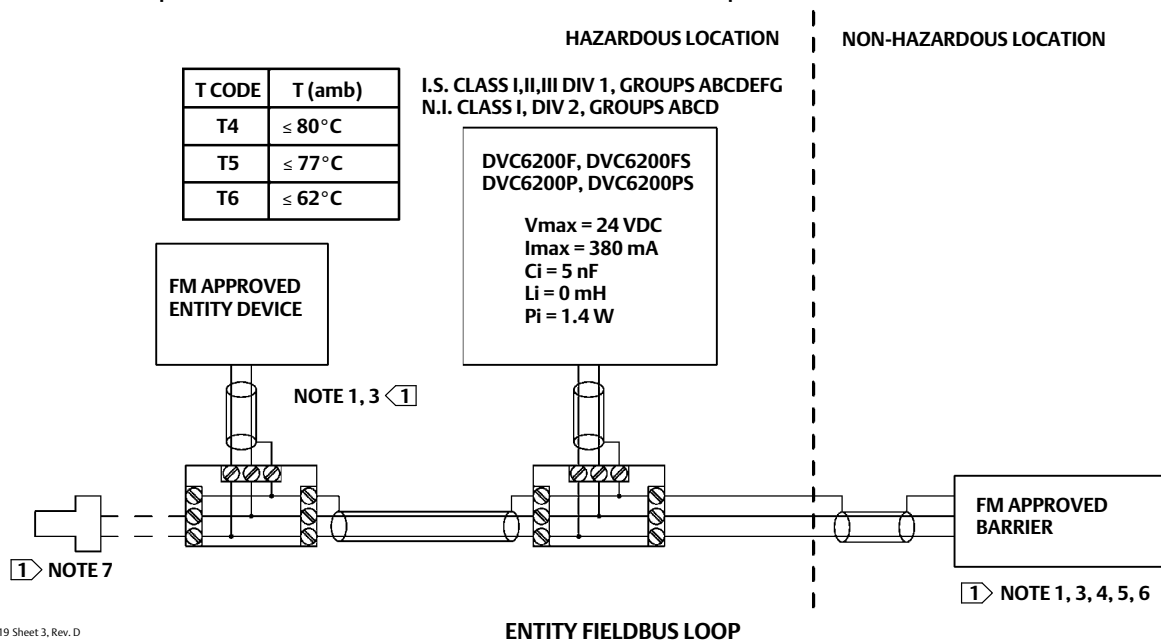
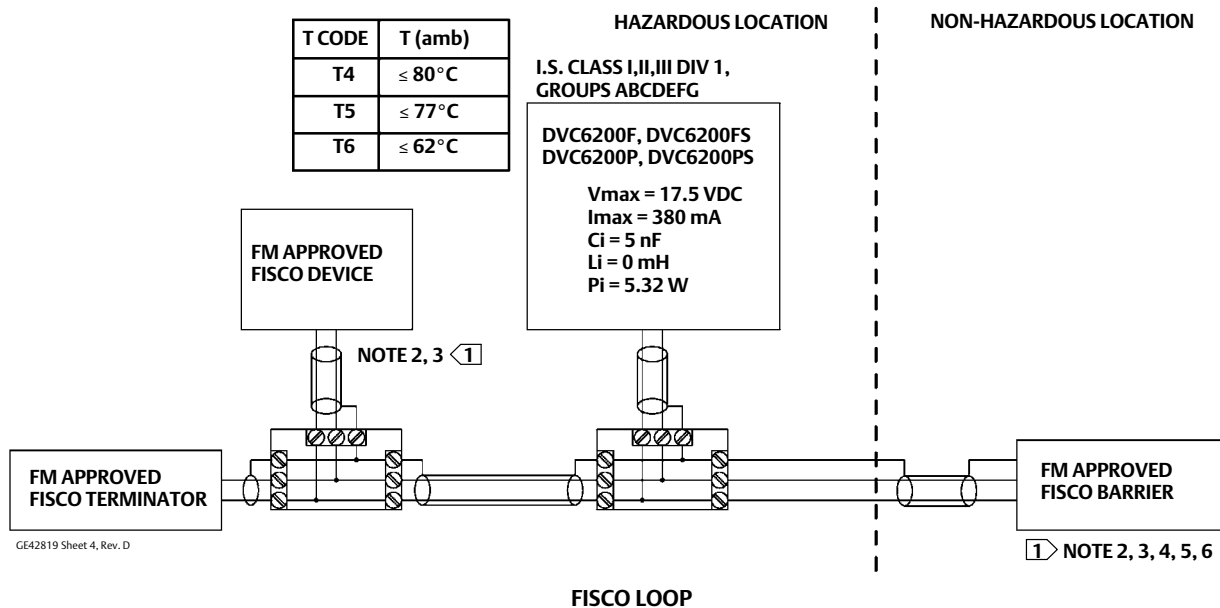

Figure 46. FM Loop Schematics—FIELDVUE DVC6200f and DVC6200p



GE42819 Sheet 3, Rev. D



GE42819 Sheet 4, Rev. D

SEE NOTES IN FIGURE 48

Figure 47. FM Loop Schematics—FIELDVUE DVC6205f, DVC6205p, and DVC6215

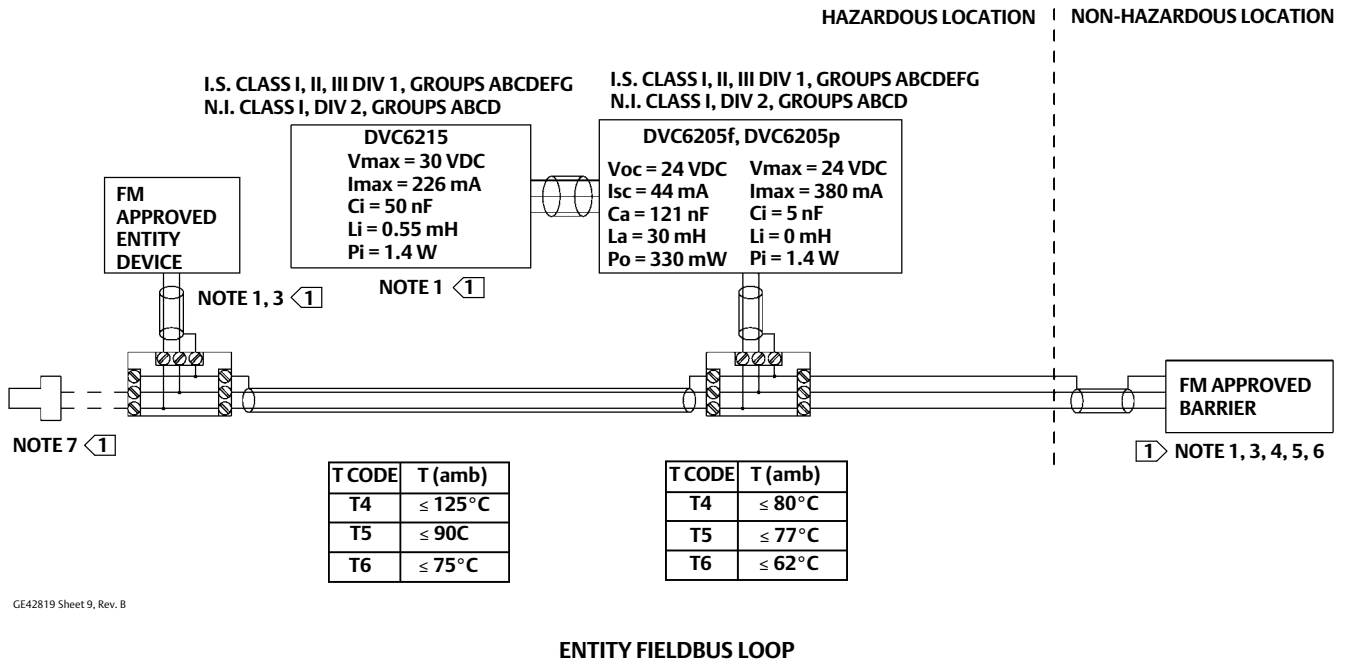

GE42819 Sheet 9, Rev. B

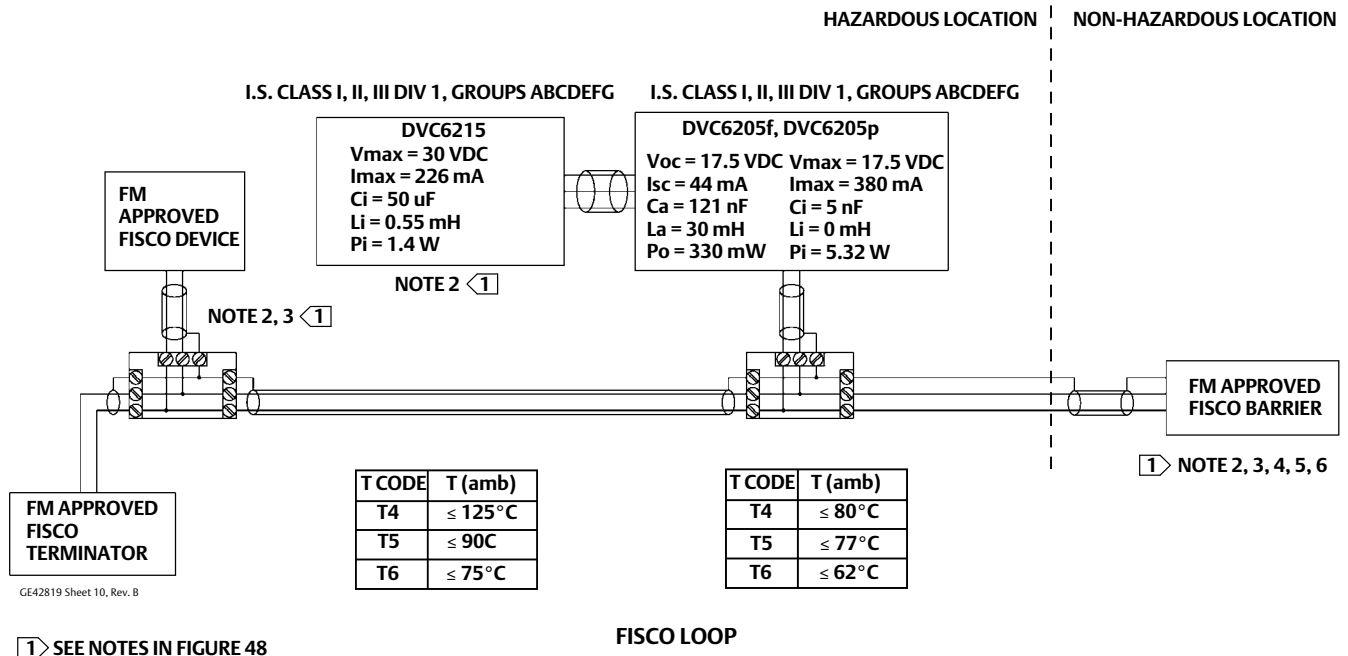

GE42819 Sheet 10, Rev. B

SEE NOTES IN FIGURE 48



Figure 48. Notes for FM Loop Schematics

1 THE ENTITY CONCEPT ALLOWS INTERCONNECTION OF INTRINSICALLY SAFE APPARATUS TO ASSOCIATED APPARATUS NOT SPECIFICALLY EXAMINED IN SUCH COMBINATION. THE CRITERIA FOR INTERCONNECTION IS THAT THE VOLTAGE ( $V_{max}$  OR  $U_i$ ), THE CURRENT ( $I_{max}$  OR  $I_i$ ), AND THE POWER ( $P_{max}$  OR  $P_i$ ) OF THE INTRINSICALLY SAFE APPARATUS MUST BE EQUAL TO OR GREATER THAN THE VOLTAGE ( $V_{oc}$  OR  $U_o$ ), AND THE CURRENT ( $I_{sc}$  OR  $I_o$ ), AND THE POWER ( $P_o$ ) DEFINED BY THE ASSOCIATED APPARATUS. IN ADDITION, THE SUM OF THE MAX UNPROTECTED CAPACITANCE ( $C_i$ ) AND MAX UNPROTECTED INDUCTANCE ( $L_i$ ), INCLUDING THE INTERCONNECTING CABLING CAPACITANCE ( $C_{cable}$ ) AND CABLING INDUCTANCE ( $L_{cable}$ ) MUST BE LESS THAN THE ALLOWABLE CAPACITANCE ( $C_a$ ) AND INDUCTANCE ( $L_a$ ) DEFINED BY THE ASSOCIATED APPARATUS. IF THE ABOVE CRITERIA IS MET, THEN THE COMBINATION MAY BE CONNECTED.

$$V_{max} \text{ or } U_i \geq V_{oc} \text{ or } U_o \quad I_{max} \text{ or } I_i \geq I_{sc} \text{ or } I_o \quad P_{max} \text{ or } P_i \geq P_o \quad C_i + C_{cable} \leq C_a \quad L_i + L_{cable} \leq L_a$$

2 THE FISCO CONCEPT ALLOWS INTERCONNECTION OF INTRINSICALLY SAFE APPARATUS TO ASSOCIATED APPARATUS NOT SPECIFICALLY EXAMINED IN SUCH COMBINATION. THE CRITERIA FOR THE INTERCONNECTION IS THAT THE VOLTAGE ( $V_{max}$  OR  $U_i$ ), CURRENT ( $I_{max}$  OR  $I_i$ ), AND POWER ( $P_{max}$  OR  $P_i$ ), WHICH AN INTRINSICALLY SAFE APPARATUS CAN RECEIVE AND REMAIN INTRINSICALLY SAFE, CONSIDERING FAULTS, MUST BE EQUAL TO OR GREATER THAN THE VOLTAGE ( $V_{oc}$  OR  $U_o$ ), CURRENT ( $I_{sc}$  OR  $I_o$ ), AND POWER ( $P_o$ ) LEVELS WHICH CAN BE DELIVERED BY THE ASSOCIATED APPARATUS, CONSIDERING FAULTS AND APPLICABLE FACTORS. IN ADDITION THE MAXIMUM UNPROTECTED CAPACITANCE ( $C_i$ ) AND INDUCTANCE ( $L_i$ ) OF EACH APPARATUS (OTHER THAN THE TERMINATION) CONNECTED TO THE FIELDBUS MUST BE LESS THAN OR EQUAL TO 5 nF AND 10 uH RESPECTIVELY.

IN EACH SEGMENT ONLY ONE ACTIVE DEVICE, NORMALLY THE ASSOCIATED APPARATUS, IS ALLOWED TO PROVIDE THE NECESSARY ENERGY FOR THE FIELDBUS SYSTEM. THE VOLTAGE ( $U_o$  OR  $V_{oc}$  OR  $V_t$ ) OF THE ASSOCIATED APPARATUS HAS TO BE LIMITED TO THE RANGE OF 9 V TO 17.5 VDC. ALL OTHER EQUIPMENT CONNECTED TO THE BUS CABLE HAS TO BE PASSIVE, MEANING THAT THEY ARE NOT ALLOWED TO PROVIDE ENERGY TO THE SYSTEM, EXCEPT FOR A LEAKAGE CURRENT OF 50 uA FOR EACH CONNECTED DEVICE. SEPARATELY POWERED EQUIPMENT NEEDS A GALVANIC ISOLATION TO ASSURE THAT THE INTRINSICALLY SAFE FIELDBUS CIRCUIT REMAINS PASSIVE.

THE CABLE USED TO CONNECT THE DEVICES NEEDS TO HAVE THE PARAMETERS IN THE FOLLOWING RANGE:

LOOP RESISTANCE R':	15 TO 150 ohms/km
INDUCTANCE PER UNIT LENGTH L:	0.4 TO 1 mH/km
CAPACITANCE PER UNIT LENGTH C':	80 TO 200 nF/km
C' = C' LINE/LINE + 0.5' LINE/SCREEN, IF BOTH LINES ARE FLOATING OR	
C' = C' LINE/LINE + C' LINE/SCREEN, IF THE SCREEN IS CONNECTED TO ONE LINE.	
LENGTH OF SPLICE:	< 1 m (T-BOX MUST ONLY CONTAIN TERMINAL CONNECTIONS WITH NO ENERGY STORAGE CAPABILITY)
LENGTH OF SPUR CABLE:	< 30 M
LENGTH OF TRUNK CABLE:	< 1 km

AT EACH END OF THE TRUNK CABLE AN APPROVED INFALLIBLE TERMINATION WITH THE FOLLOWING PARAMETERS IS SUITABLE:

$$R = 90 \text{ TO } 100 \text{ ohms AND } C = 0 \text{ TO } 2.2 \text{ uF}$$

NOTE, A BUILT-IN TERMINATOR IS INCLUDED IN THE FIELD SIDE AND A SELECTABLE TERMINATOR IS AVAILABLE ON THE HOST SIDE.

THE NUMBER OF PASSIVE DEVICES CONNECTED TO THE BUS SEGMENT IS NOT LIMITED IN THE FISCO CONCEPT FOR INTRINSICALLY SAFE REASONS. IF THE ABOVE RULES ARE RESPECTED, UP TO A TOTAL LENGTH OF 1000 m (SUM OF THE LENGTH OF THE TRUNK CABLE AND ALL SPUR CABLES), THE INDUCTANCE AND CAPACITANCE OF THE CABLE WILL NOT IMPAIR THE INTRINSIC SAFETY OF THE INSTALLATION.

3 INSTALLATION MUST BE IN ACCORDANCE WITH THE NATIONAL ELECTRICAL CODE (NEC) AND ANSI/ISA RP12.6.01.

4 MAXIMUM SAFE AREA VOLTAGE SHOULD NOT EXCEED 250 Vrms.

5 RESISTANCE BETWEEN INTRINSICALLY SAFE GROUND AND EARTH GROUND MUST BE LESS THAN ONE OHM

6 LOOPS MUST BE CONNECTED ACCORDING TO THE BARRIER MANUFACTURER'S INSTRUCTIONS.

7 IF HAND-HELD COMMUNICATOR OR MULTIPLEXER IS USED, IT MUST BE FM APPROVED WITH ENTITY PARAMETERS AND INSTALLED PER THE MANUFACTURER'S CONTROL DRAWINGS.

**⚠ WARNING**

THE APPARATUS ENCLOSURE CONTAINS ALUMINUM AND IS CONSIDERED TO CONSTITUTE A POTENTIAL RISK OF IGNITION BY IMPACT AND FRICTION. AVOID IMPACT AND FRICTION DURING INSTALLATION AND USE TO PREVENT RISK OF IGNITION.

**ATEX**Flameproof  II 2 G**⚠ WARNING****Do not open while energized.****Potential electrostatic charging hazard. See warning on page 3.****DVC6200 and DVC6205 Series (HART HW1 & HW2, SIS, FOUNDATION FIELDBUS, PROFIBUS)**Ex d IIC T5 ( $T_a \leq 85^\circ\text{C}$ )Ex d IIC T6 ( $T_a \leq 80^\circ\text{C}$ )

Operating ambient temperature

Standard construction  $-40^\circ\text{C}$  to  $+85^\circ\text{C}$ ,Extreme temperature construction  $-52^\circ\text{C}$  to  $+85^\circ\text{C}$ Type n  II 3 G**⚠ WARNING****Do not open while energized.****Potential electrostatic charging hazard. See warning on page 3.****DVC6200 and DVC6205 Series (HART HW1 & HW2, SIS, FOUNDATION FIELDBUS, PROFIBUS)**Ex nC IIC T5 ( $T_a \leq 80^\circ\text{C}$ )Ex nC IIC T6 ( $T_a \leq 75^\circ\text{C}$ )

Operating ambient temperature

Standard construction  $-40^\circ\text{C}$  to  $+80^\circ\text{C}$ ,Extreme temperature construction  $-52^\circ\text{C}$  to  $+80^\circ\text{C}$ **Intrinsically Safe****⚠ WARNING****Potential electrostatic charging hazard. See warning on page 3.****DVC6200 and DVC6205 Series (HART HW1 & HW2, SIS, FOUNDATION FIELDBUS, PROFIBUS)** II 1 GD

Operating ambient temperature

Standard construction  $-40^\circ\text{C}$  to  $+80^\circ\text{C}$ ,Extreme temperature construction  $-52^\circ\text{C}$  to  $+80^\circ\text{C}$ **DVC6215** II 1 G $-52^\circ\text{C} \leq T_a \leq +125^\circ\text{C}$

Intrinsically safe when connected per control drawing GE60771, as shown in the following figures

- DVC6200 HW1 ..... figure 49 and 54
- DVC6200 HW2, DVC6200 SIS ..... figure 50 and 54
- DVC6205, DVC6205 SIS, and DVC6215 Remote Mount ..... figure 51 and 54
- DVC6200f and DVC6200p ..... figure 52 and 54
- DVC6205f, DVC6205p, and DVC6215 Remote Mount ..... figure 53 and 54

### Special Conditions for Safe Use; Intrinsically Safe Applications

- This apparatus can only be connected to an intrinsically safe certified equipment and this combination must be compatible as regards the intrinsically safe rules.
- Covered by standards EN 60079-0 (2009), EN 60079-11 (2012), EN 60079-26 (2007).
- For the model with aluminum body: the apparatus must not be submitted to frictions or mechanical impacts.

Figure 49. ATEX Loop Schematic—FIELDVUE DVC6200 HW1

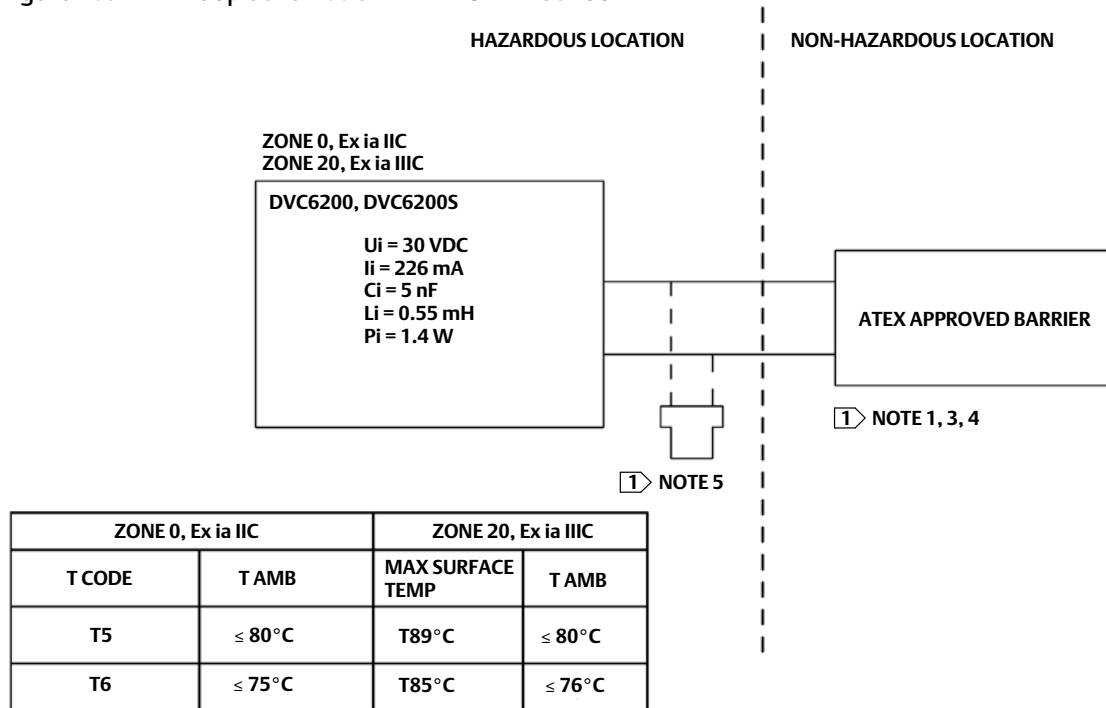

SEE NOTES IN FIGURE 54

GE60771 sheet 3, Rev. B

Figure 50. ATEX Loop Schematics—FIELDVUE DVC6200 HW2 and DVC6200 SIS

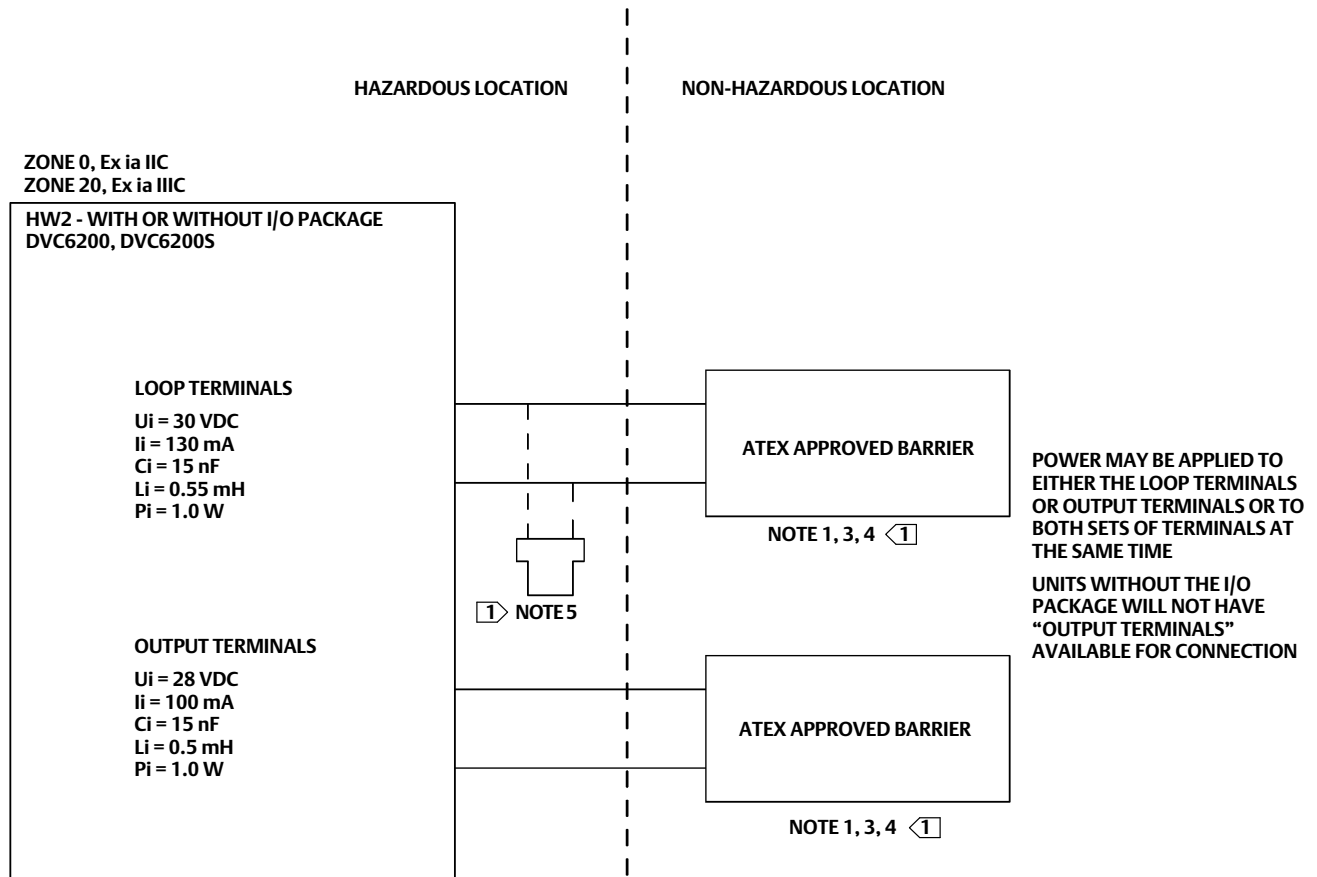

ZONE 0, Ex ia IIC				ZONE 20, Ex ia IIIC			
WITHOUT I/O PACKAGE		WITH I/O PACKAGE		WITHOUT I/O PACKAGE		WITH I/O PACKAGE	
T CODE	T AMB	T CODE	T AMB	MAX SURFACE TEMP	T AMB	MAX SURFACE TEMP	T AMB
T5	≤ 80°C	T5	≤ 80°C	T91°C	≤ 80°C	T104°C	≤ 80°C
T6	≤ 74°C	T6	≤ 61°C	T85°C	≤ 74°C	T85°C	≤ 61°C

SEE NOTES IN FIGURE 54

GE60771 Sheet 11, Rev. B

Figure 51. ATEX Loop Schematics—FIELDVUE DVC6205, DVC6205 SIS, and DVC6215

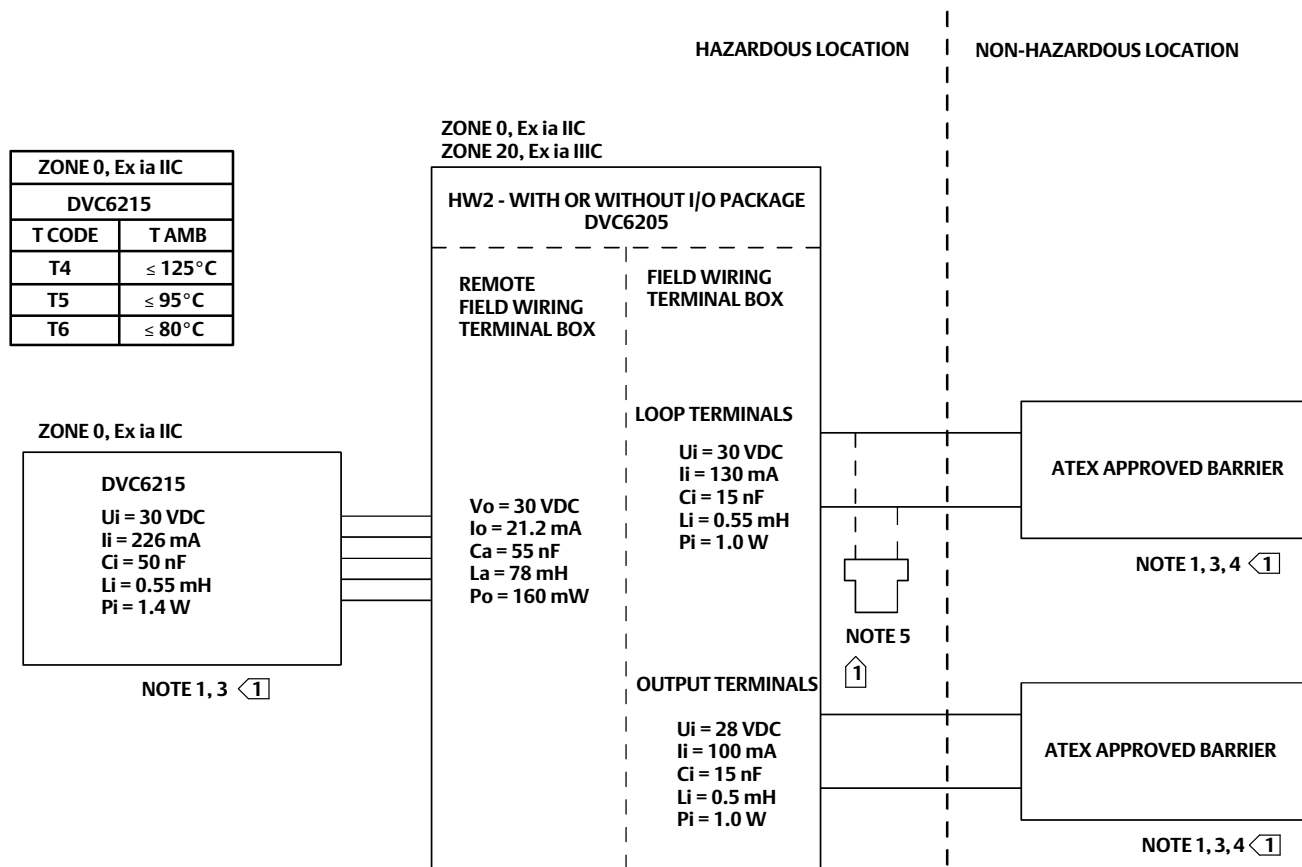

POWER MAY BE APPLIED TO EITHER THE LOOP TERMINALS OR OUTPUT TERMINALS OR TO BOTH SETS OF TERMINALS AT THE SAME TIME  
UNITS WITHOUT THE I/O PACKAGE WILL NOT HAVE "OUTPUT TERMINALS" AVAILABLE FOR CONNECTION

	ZONE 0, Ex ia IIC				ZONE 20, Ex ia IIIC			
	WITHOUT I/O PACKAGE		WITH I/O PACKAGE		WITHOUT I/O PACKAGE		WITH I/O PACKAGE	
TYPE	T CODE	T AMB	T CODE	T AMB	MAX SURFACE TEMP	T AMB	MAX SURFACE TEMP	T AMB
DVC6205	T5	≤ 80°C	T5	≤ 80°C	T91°C	≤ 80°C	T104°C	≤ 80°C
	T6	≤ 74°C	T6	≤ 61°C	T85°C	≤ 74°C	T85°C	≤ 61°C

SEE NOTES IN FIGURE 54

GE60771 Sheet 12, Rev. B

Figure 52. ATEX Loop Schematics—FIELDVUE DVC6200f and DVC6200p

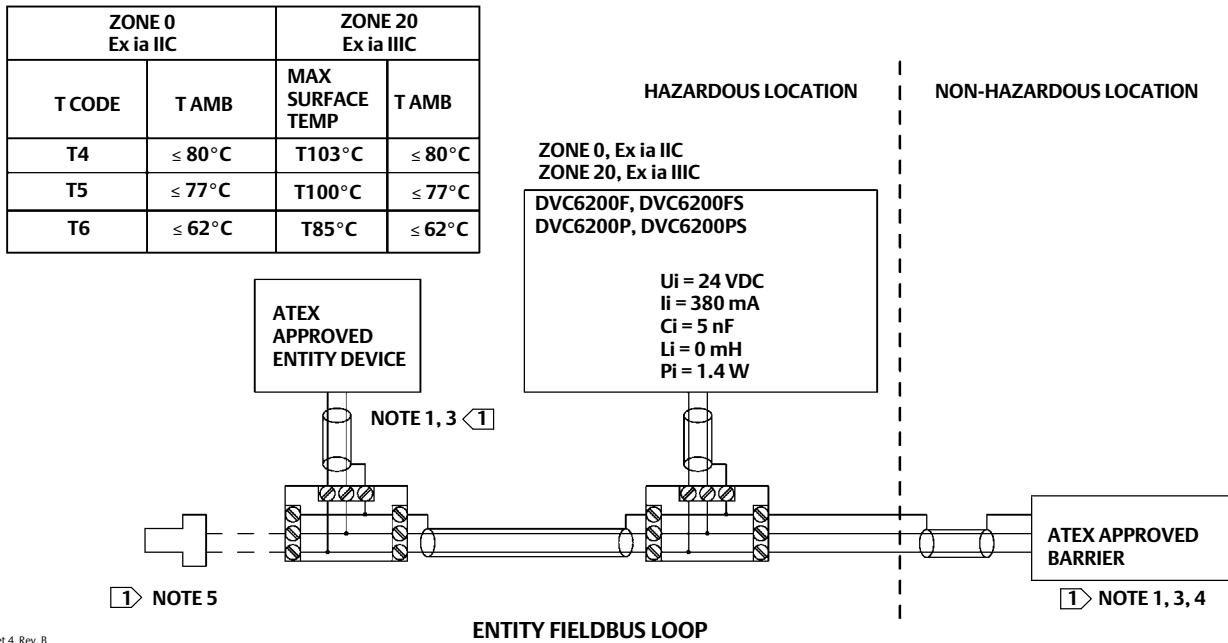

CE60771 Sheet 4, Rev. B

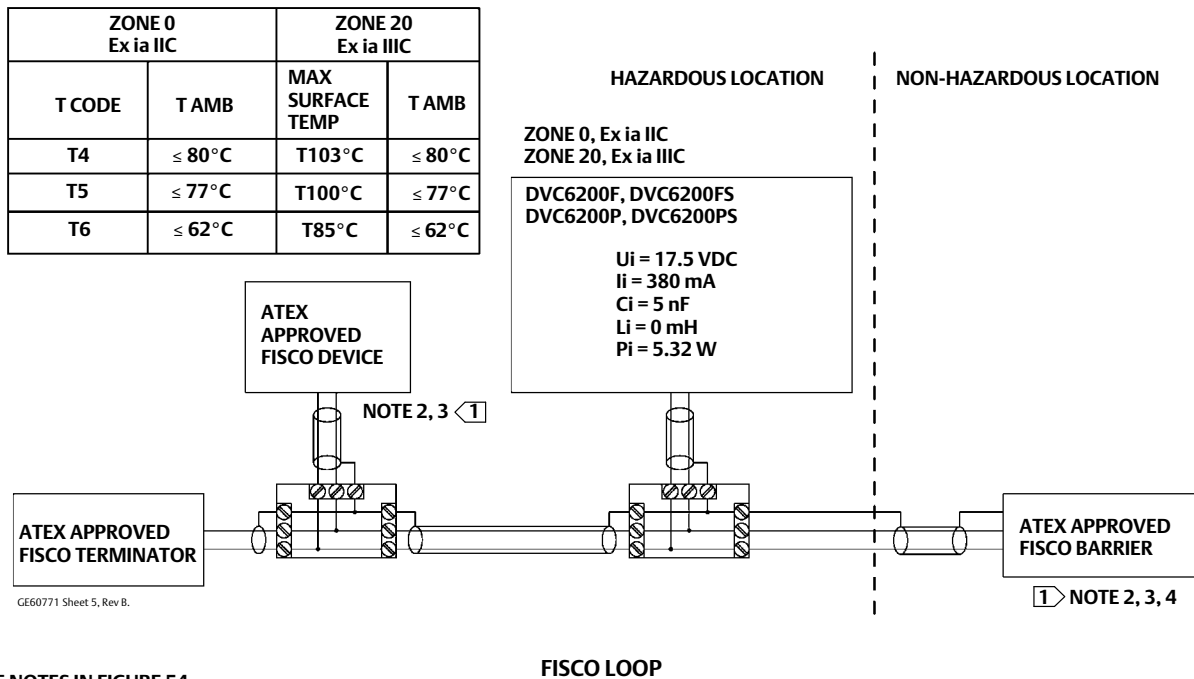

CE60771 Sheet 5, Rev. B

SEE NOTES IN FIGURE 54

Figure 53. ATEX Loop Schematics—FIELDVUE DVC6205f, DVC6205p, and DVC6215

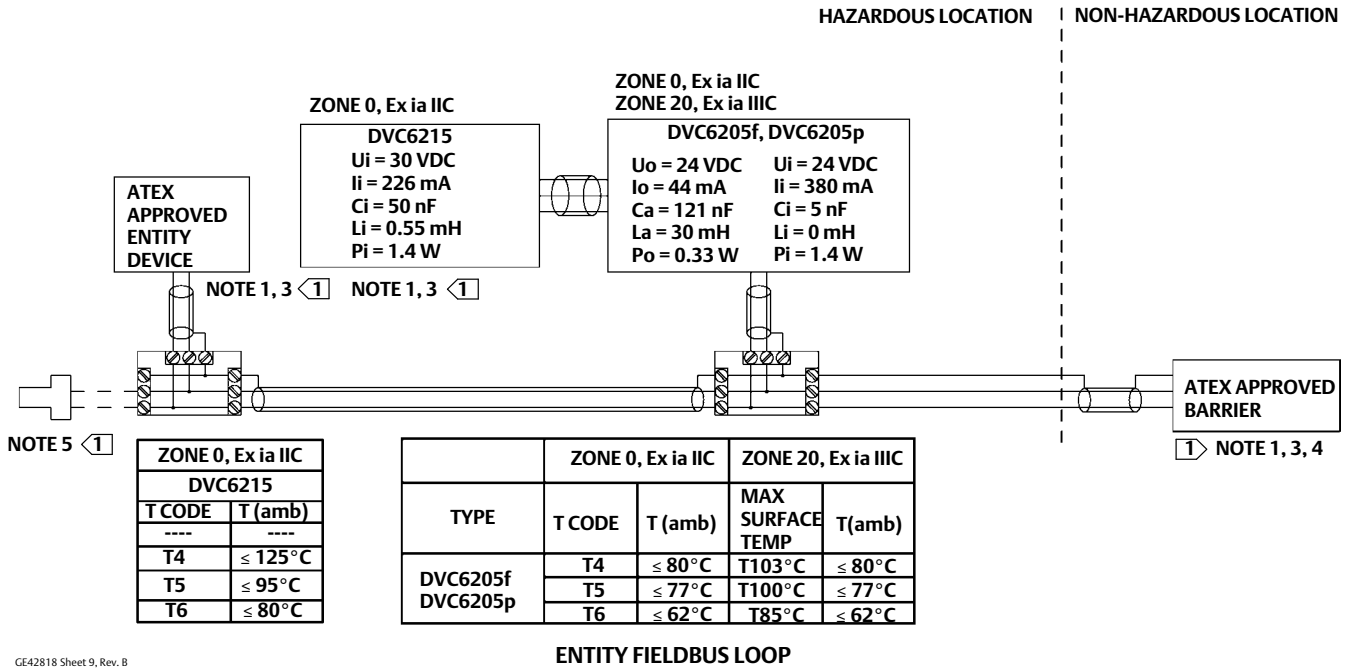

GE42818 Sheet 9, Rev. B

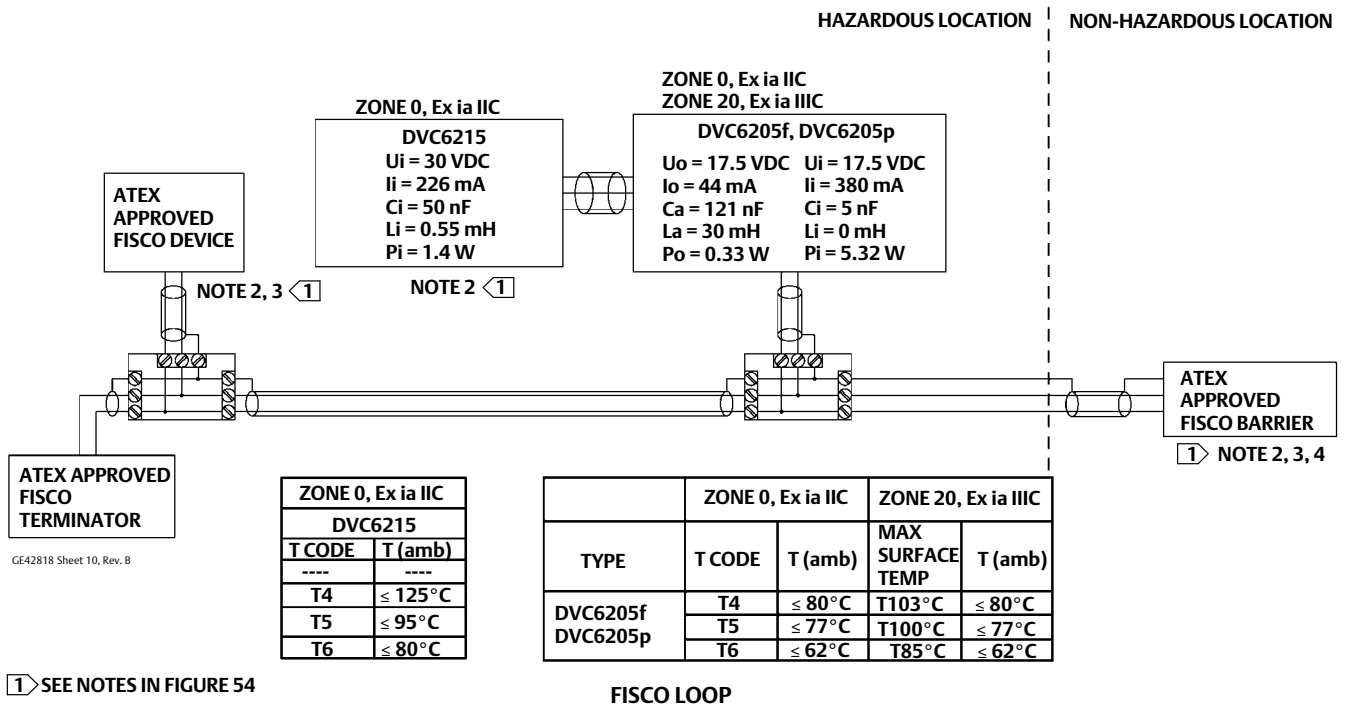

GE42818 Sheet 10, Rev. B

SEE NOTES IN FIGURE 54

Figure 54. Notes for ATEX Loop Schematics

① THE ENTITY CONCEPT ALLOWS INTERCONNECTION OF INTRINSICALLY SAFE APPARATUS TO ASSOCIATED APPARATUS NOT SPECIFICALLY EXAMINED IN SUCH COMBINATION. THE CRITERIA FOR INTERCONNECTION IS THAT THE VOLTAGE ( $V_{max}$  or  $U_i$ ), THE CURRENT ( $I_{max}$  or  $I_i$ ), AND THE POWER ( $P_{max}$  or  $P_i$ ) OF THE INTRINSICALLY SAFE APPARATUS MUST BE EQUAL TO OR GREATER THAN THE VOLTAGE ( $V_{oc}$  or  $U_o$ ), AND THE CURRENT ( $I_{sc}$  or  $I_o$ ), AND THE POWER ( $P_o$ ) DEFINED BY THE ASSOCIATED APPARATUS. IN ADDITION, THE SUM OF THE MAX UNPROTECTED CAPACITANCE ( $C_i$ ) AND MAX UNPROTECTED INDUCTANCE ( $L_i$ ), INCLUDING THE INTERCONNECTING CABLING CAPACITANCE ( $C_{cable}$ ) AND CABLING INDUCTANCE ( $L_{cable}$ ) MUST BE LESS THAN THE ALLOWABLE CAPACITANCE ( $C_a$ ) AND INDUCTANCE ( $L_a$ ) DEFINED BY THE ASSOCIATED APPARATUS. IF THE ABOVE CRITERIA IS MET, THEN THE COMBINATION MAY BE CONNECTED.

$$V_{max} \text{ or } U_i \geq V_{oc} \text{ or } U_o \quad I_{max} \text{ or } I_i \geq I_{sc} \text{ or } I_o \quad P_{max} \text{ or } P_i \geq P_o \quad C_i + C_{cable} \leq C_a \quad L_i + L_{cable} \leq L_a$$

② THE FISCO CONCEPT ALLOWS INTERCONNECTION OF INTRINSICALLY SAFE APPARATUS TO ASSOCIATED APPARATUS NOT SPECIFICALLY EXAMINED IN SUCH COMBINATION. THE CRITERIA FOR THE INTERCONNECTION IS THAT THE VOLTAGE ( $V_{max}$  or  $U_i$ ), CURRENT ( $I_{max}$  or  $I_i$ ), AND POWER ( $P_{max}$  or  $P_i$ ), WHICH AN INTRINSICALLY SAFE APPARATUS CAN RECEIVE AND REMAIN INTRINSICALLY SAFE, CONSIDERING FAULTS, MUST BE EQUAL TO OR GREATER THAN THE VOLTAGE ( $V_{oc}$  or  $U_o$ ), CURRENT ( $I_{sc}$  or  $I_o$ ), AND POWER ( $P_o$ ) LEVELS WHICH CAN BE DELIVERED BY THE ASSOCIATED APPARATUS, CONSIDERING FAULTS AND APPLICABLE FACTORS. IN ADDITION THE MAXIMUM UNPROTECTED CAPACITANCE ( $C_i$ ) AND INDUCTANCE ( $L_i$ ) OF EACH APPARATUS (OTHER THAN THE TERMINATION) CONNECTED TO THE FIELDBUS MUST BE LESS THAN OR EQUAL TO 5 nF AND 10  $\mu$ H RESPECTIVELY.

IN EACH SEGMENT ONLY ONE ACTIVE DEVICE, NORMALLY THE ASSOCIATED APPARATUS, IS ALLOWED TO PROVIDE THE NECESSARY ENERGY FOR THE FIELDBUS SYSTEM. THE VOLTAGE ( $U_o$  or  $V_{oc}$  or  $V_t$ ) OF THE ASSOCIATED APPARATUS HAS TO BE LIMITED TO THE RANGE OF 9 V TO 17.5 VDC. ALL OTHER EQUIPMENT CONNECTED TO THE BUS CABLE HAS TO BE PASSIVE, MEANING THAT THEY ARE NOT ALLOWED TO PROVIDE ENERGY TO THE SYSTEM, EXCEPT FOR A LEAKAGE CURRENT OF 50  $\mu$ A FOR EACH CONNECTED DEVICE. SEPARATELY POWERED EQUIPMENT NEEDS A GALVANIC ISOLATION TO ASSURE THAT THE INTRINSICALLY SAFE FIELDBUS CIRCUIT REMAINS PASSIVE.

THE CABLE USED TO CONNECT THE DEVICES NEEDS TO HAVE THE PARAMETERS IN THE FOLLOWING RANGE:

LOOP RESISTANCE R':	15 TO 150 ohms/km
INDUCTANCE PER UNIT LENGTH L:	0.4 TO 1 mH/km
CAPACITANCE PER UNIT LENGTH C':	80 TO 200 nF/km
C' = C' LINE/LINE + 0.5' LINE/SCREEN, IF BOTH LINES ARE FLOATING OR	
C' = C' LINE/LINE + C' LINE/SCREEN, IF THE SCREEN IS CONNECTED TO ONE LINE.	
LENGTH OF SPLICE:	< 1 m (T-BOX MUST ONLY CONTAIN TERMINAL CONNECTIONS WITH NO ENERGY STORAGE CAPABILITY)
LENGTH OF SPUR CABLE:	< 30 M
LENGTH OF TRUNK CABLE:	< 1 km

AT EACH END OF THE TRUNK CABLE AN APPROVED INFALLIBLE TERMINATION WITH THE FOLLOWING PARAMETERS IS SUITABLE:

$$R = 90 \text{ TO } 100 \text{ ohms AND } C = 0 \text{ TO } 2.2 \text{ }\mu\text{F}$$

NOTE, A BUILT-IN TERMINATOR IS INCLUDED IN THE FIELD SIDE AND A SELECTABLE TERMINATOR IS AVAILABLE ON THE HOST SIDE.

THE NUMBER OF PASSIVE DEVICES CONNECTED TO THE BUS SEGMENT IS NOT LIMITED IN THE FISCO CONCEPT FOR INTRINSICALLY SAFE REASONS. IF THE ABOVE RULES ARE RESPECTED, UP TO A TOTAL LENGTH OF 1000 m (SUM OF THE LENGTH OF THE TRUNK CABLE AND ALL SPUR CABLES), THE INDUCTANCE AND CAPACITANCE OF THE CABLE WILL NOT IMPAIR THE INTRINSIC SAFETY OF THE INSTALLATION.

③ INSTALLATION MUST BE IN ACCORDANCE WITH THE NATIONAL WIRING PRACTICES OF THE COUNTRY IN USE.

④ LOOPS MUST BE CONNECTED ACCORDING TO THE BARRIER MANUFACTURER'S INSTRUCTIONS.

⑤ IF HAND-HELD COMMUNICATOR OR MULTIPLEXER IS USED, IT MUST BE ATEX APPROVED WITH ENTITY PARAMETERS AND INSTALLED PER THE MANUFACTURER'S CONTROL DRAWINGS.



## IECEX

### Flameproof

#### **⚠ WARNING**

Do not open while energized.

Potential electrostatic charging hazard. See warning on page 3.

---

#### **DVC6200 and DVC6205 Series (HART HW1 & HW2, SIS, FOUNDATION FIELDBUS, PROFIBUS)**

Ex d IIC T5 ( $T_a \leq 80^\circ\text{C}$ ) / T6 ( $T_a \leq 75^\circ\text{C}$ )  
30 V max, 20 mA  
IP66

#### **DVC6215 Remote Mount**

Ex d IIC T4 ( $T_a \leq 125^\circ\text{C}$ ) / T5 ( $T_a \leq 95^\circ\text{C}$ ) / T6 ( $T_a \leq 80^\circ\text{C}$ )  
30 V max, 20 mA  
IP66

### Type n

#### **⚠ WARNING**

Do not open while energized.

Potential electrostatic charging hazard. See warning on page 3.

---

#### **DVC6200 and DVC6205 Series (HART HW1 & HW2, SIS, FOUNDATION FIELDBUS, PROFIBUS)**

Ex nC IIC T5 ( $T_a \leq 80^\circ\text{C}$ ) / T6 ( $T_a \leq 75^\circ\text{C}$ )  
30 V max, 20 mA  
IP66

#### **DVC6215 Remote Mount**

Ex nA IIC T4 ( $T_a \leq 125^\circ\text{C}$ ) / T5 ( $T_a \leq 95^\circ\text{C}$ ) / T6 ( $T_a \leq 80^\circ\text{C}$ )  
30 V max, 20 mA  
IP66

## Intrinsically Safe

**⚠ WARNING**

Potential electrostatic charging hazard. See warning on page 3.

Ex ia IIC  
IP66

Intrinsically safe when connected per drawing GE42990, as shown in the following figures

- DVC6200 HW1** ..... figure 55 and 60
- DVC6200 HW2 and DVC6200 SIS** ..... figure 56 and 60
- DVC6205, DVC6205 SIS, and DVC6215 Remote Mount** ..... figure 57 and 60
- DVC6200f and DVC6200p** ..... figure 58 and 60
- DVC6205f, DVC6205p, and DVC6215 Remote Mount** ..... figure 59 and 60

Figure 55. IECEx Schematic—FIELDVUE DVC6200 HW1

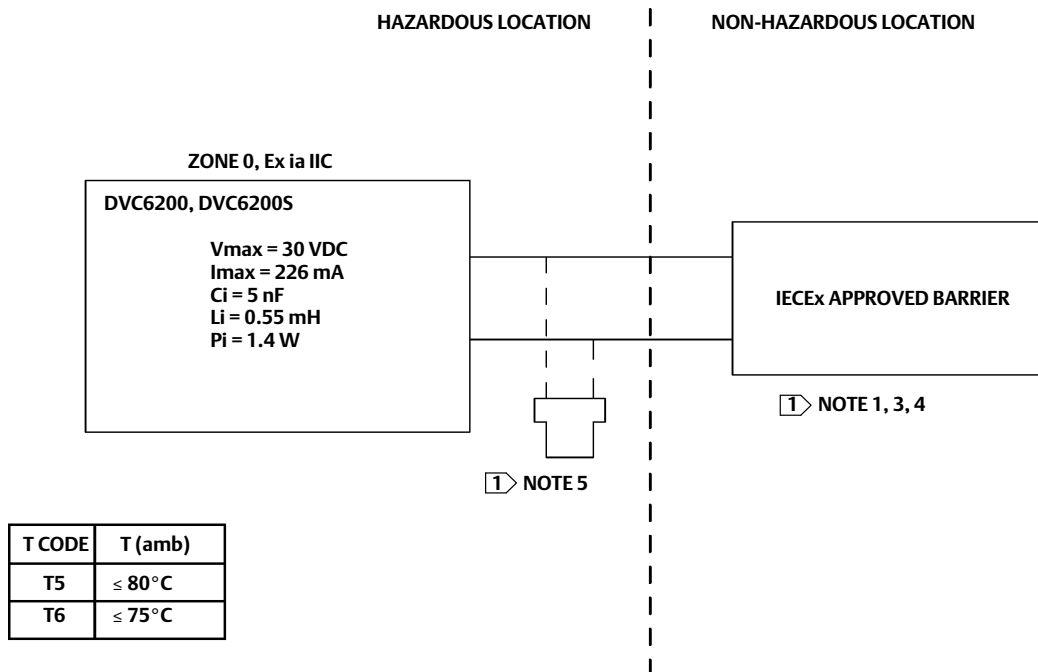

SEE NOTES IN FIGURE 60

GE42990 Sheet 2, Rev. E

Figure 56. IECEx Loop Schematics—FIELDVUE DVC6200 HW2 and DVC6200 SIS

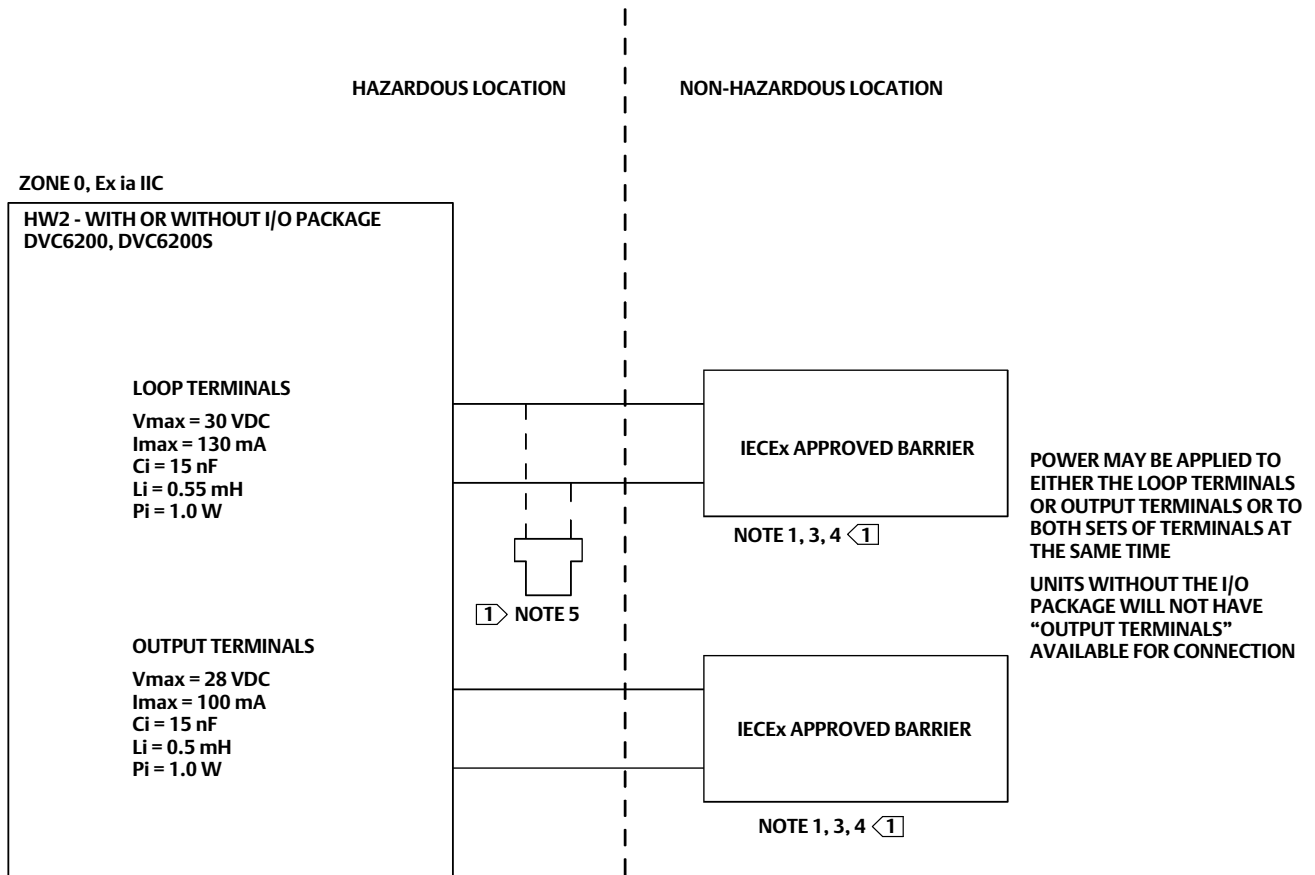

	WITH I/O PACKAGE	WITHOUT I/O PACKAGE
T CODE	T (amb)	T (amb)
T5	≤ 80°C	≤ 80°C
T6	≤ 61°C	≤ 74°C

SEE NOTES IN FIGURE 60

GE42990 Sheet 11, Rev. B

Figure 57. IECEx Loop Schematics—FIELDVUE DVC6205, DVC6205 SIS, and DVC6215

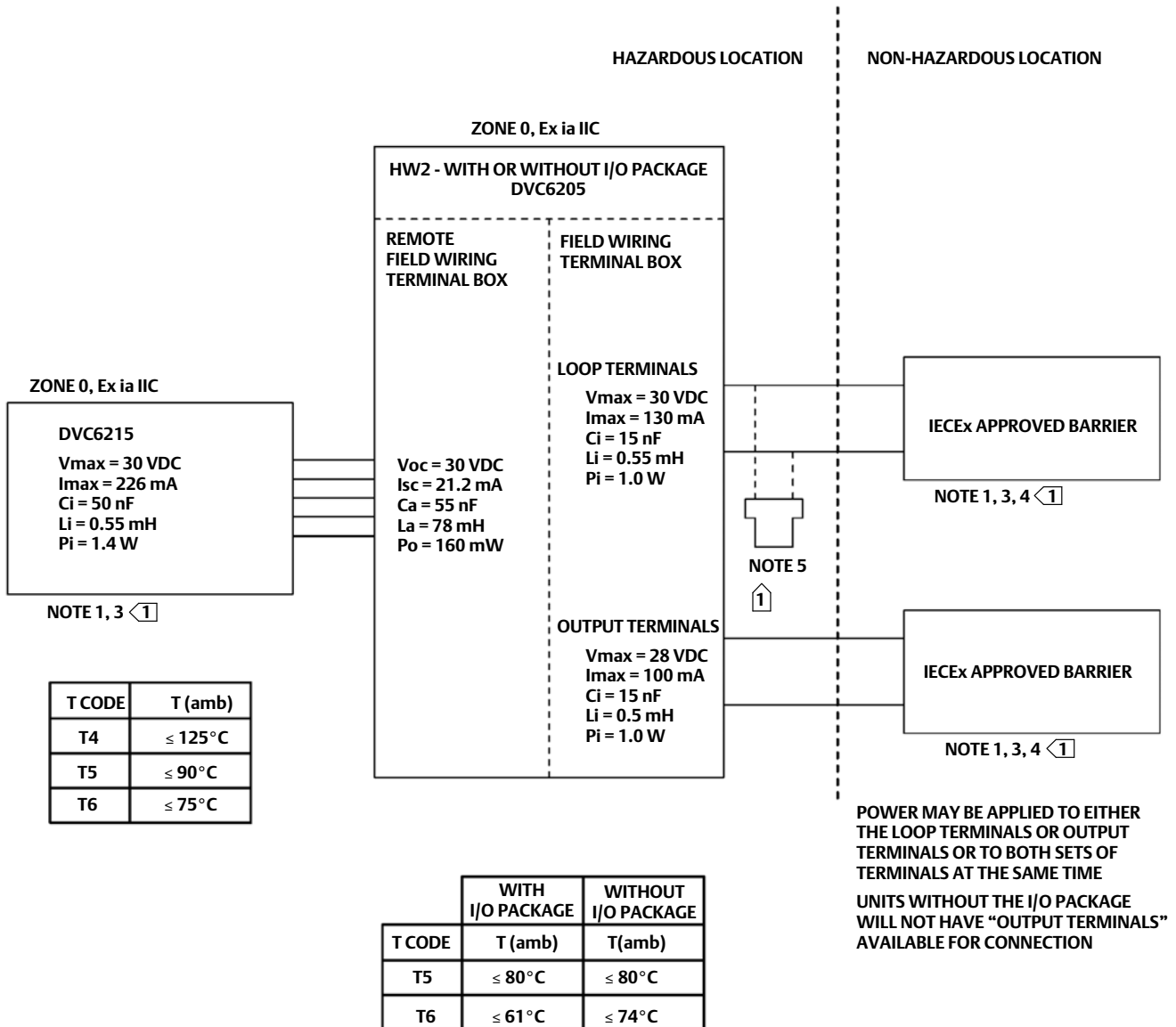

SEE NOTES IN FIGURE 60

GE42990 Sheet 12, Rev. B

Figure 58. IECEx Loop Schematics—FIELDVUE DVC6200f and DVC6200p

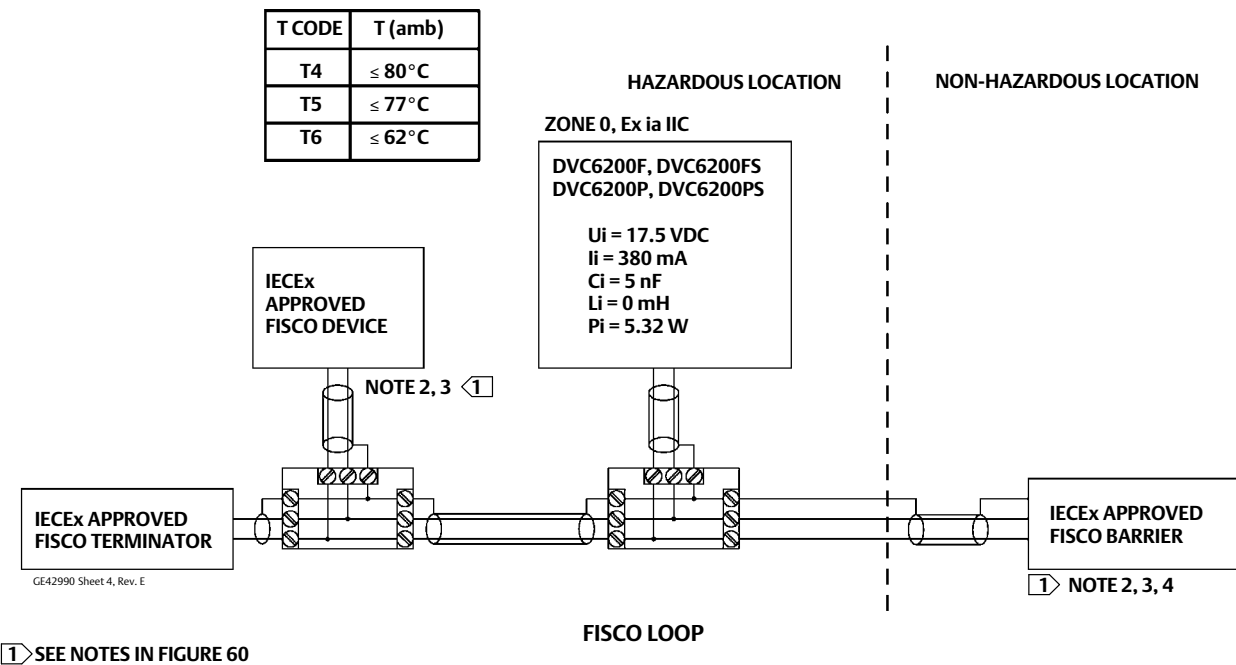
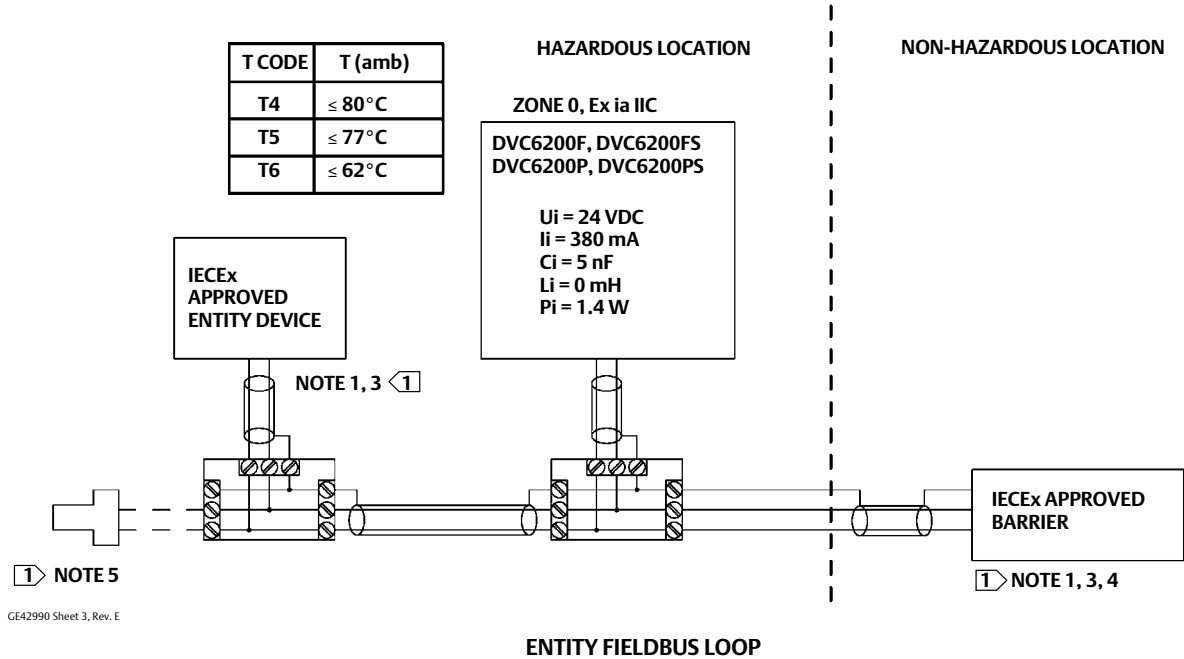
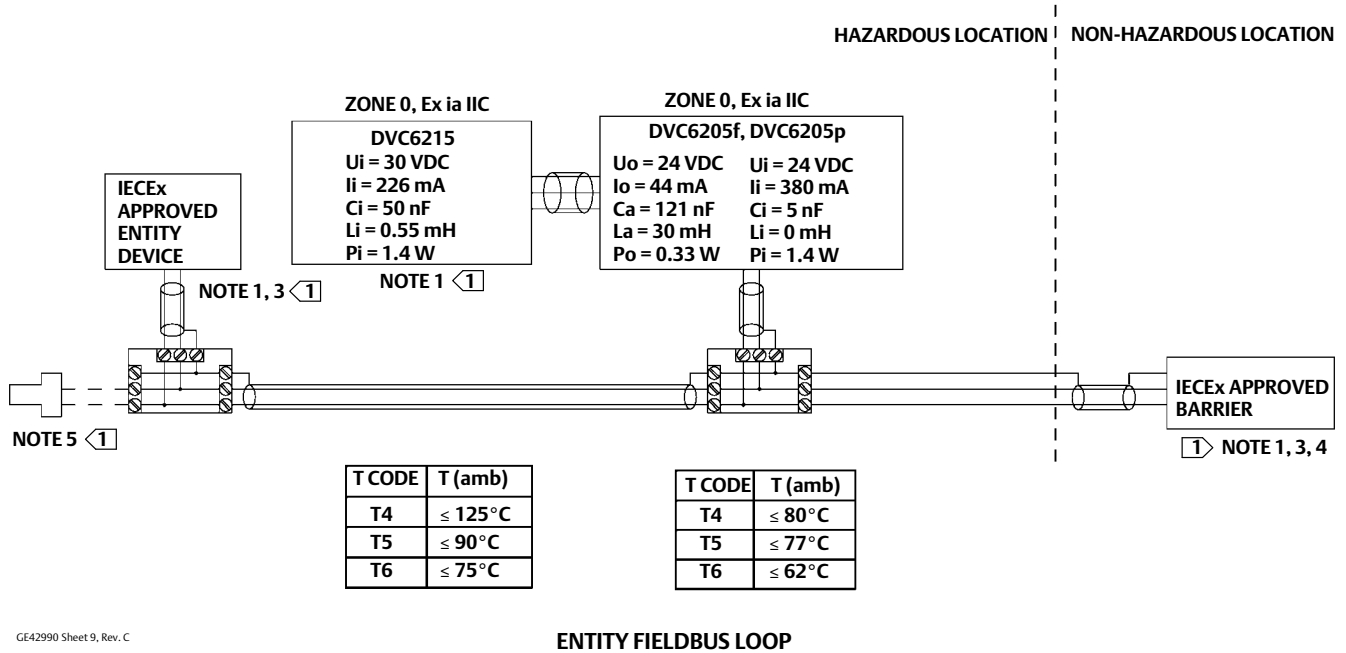
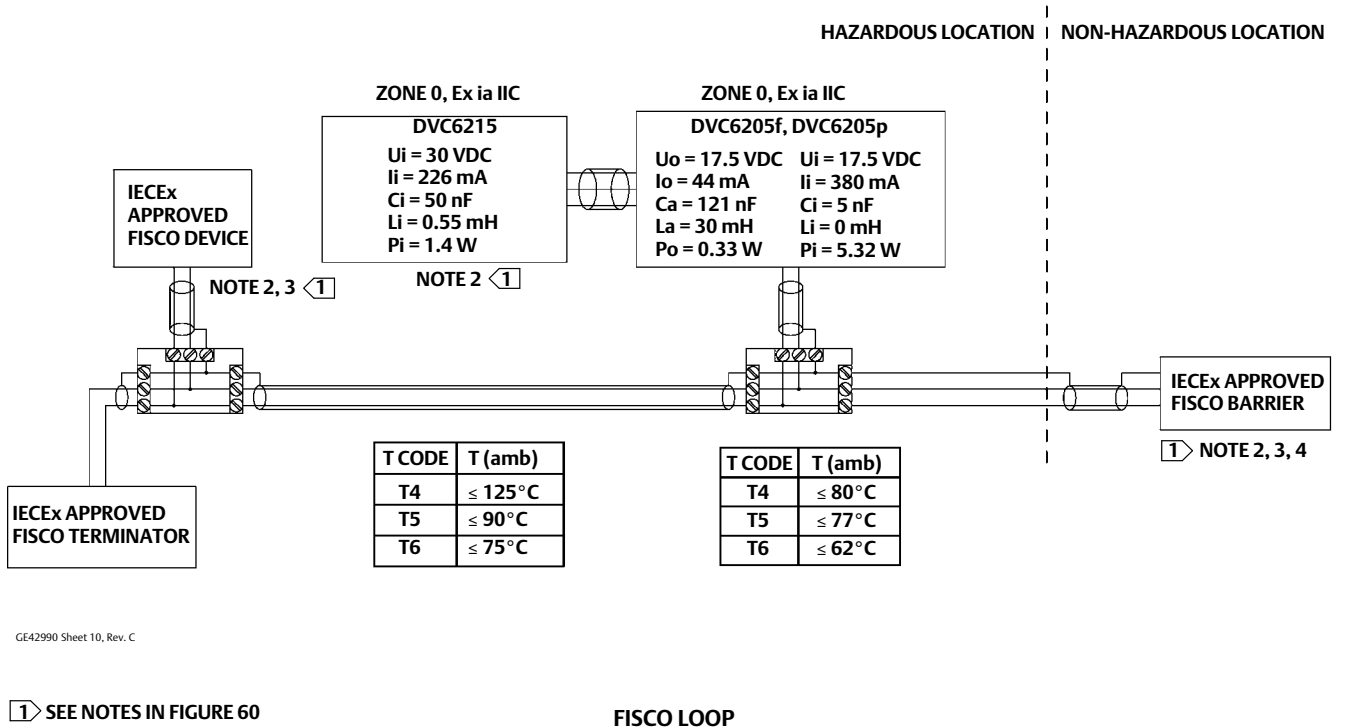

Figure 59. IECEx Loop Schematics—FIELDVUE DVC6205f, DVC6205p, and DVC6215



GE42990 Sheet 9, Rev. C



GE42990 Sheet 10, Rev. C

1 SEE NOTES IN FIGURE 60

**FISCO LOOP**

Figure 60. Notes for IECEx Loop Schematics

① THE ENTITY CONCEPT ALLOWS INTERCONNECTION OF INTRINSICALLY SAFE APPARATUS TO ASSOCIATED APPARATUS NOT SPECIFICALLY EXAMINED IN SUCH COMBINATION. THE CRITERIA FOR INTERCONNECTION IS THAT THE VOLTAGE ( $V_{max}$  OR  $U_i$ ), THE CURRENT ( $I_{max}$  OR  $I_i$ ), AND THE POWER ( $P_{max}$  OR  $P_i$ ) OF THE INTRINSICALLY SAFE APPARATUS MUST BE EQUAL TO OR GREATER THAN THE VOLTAGE ( $V_{oc}$  OR  $U_o$ ), AND THE CURRENT ( $I_{sc}$  OR  $I_o$ ), AND THE POWER ( $P_o$ ) DEFINED BY THE ASSOCIATED APPARATUS. IN ADDITION, THE SUM OF THE MAX UNPROTECTED CAPACITANCE ( $C_i$ ) AND MAX UNPROTECTED INDUCTANCE ( $L_i$ ), INCLUDING THE INTERCONNECTING CABLING CAPACITANCE ( $C_{cable}$ ) AND CABLING INDUCTANCE ( $L_{cable}$ ) MUST BE LESS THAN THE ALLOWABLE CAPACITANCE ( $C_a$ ) AND INDUCTANCE ( $L_a$ ) DEFINED BY THE ASSOCIATED APPARATUS. IF THE ABOVE CRITERIA IS MET, THEN THE COMBINATION MAY BE CONNECTED.

$$V_{max} \text{ or } U_i \geq V_{oc} \text{ or } U_o \quad I_{max} \text{ or } I_i \geq I_{sc} \text{ or } I_o \quad P_{max} \text{ or } P_i \geq P_o \quad C_i + C_{cable} \leq C_a \quad L_i + L_{cable} \leq L_a$$

② THE FISCO CONCEPT ALLOWS INTERCONNECTION OF INTRINSICALLY SAFE APPARATUS TO ASSOCIATED APPARATUS NOT SPECIFICALLY EXAMINED IN SUCH COMBINATION. THE CRITERIA FOR THE INTERCONNECTION IS THAT THE VOLTAGE ( $V_{max}$  OR  $U_i$ ), CURRENT ( $I_{max}$  OR  $I_i$ ), AND POWER ( $P_{max}$  OR  $P_i$ ), WHICH AN INTRINSICALLY SAFE APPARATUS CAN RECEIVE AND REMAIN INTRINSICALLY SAFE, CONSIDERING FAULTS, MUST BE EQUAL TO OR GREATER THAN THE VOLTAGE ( $V_{oc}$  OR  $U_o$ ), CURRENT ( $I_{sc}$  OR  $I_o$ ), AND POWER ( $P_o$ ) LEVELS WHICH CAN BE DELIVERED BY THE ASSOCIATED APPARATUS, CONSIDERING FAULTS AND APPLICABLE FACTORS. IN ADDITION THE MAXIMUM UNPROTECTED CAPACITANCE ( $C_i$ ) AND INDUCTANCE ( $L_i$ ) OF EACH APPARATUS (OTHER THAN THE TERMINATION) CONNECTED TO THE FIELDBUS MUST BE LESS THAN OR EQUAL TO 5 nF AND 10  $\mu$ H RESPECTIVELY.

IN EACH SEGMENT ONLY ONE ACTIVE DEVICE, NORMALLY THE ASSOCIATED APPARATUS, IS ALLOWED TO PROVIDE THE NECESSARY ENERGY FOR THE FIELDBUS SYSTEM. THE VOLTAGE ( $U_o$  OR  $V_{oc}$  OR  $V_t$ ) OF THE ASSOCIATED APPARATUS HAS TO BE LIMITED TO THE RANGE OF 9 V TO 17.5 VDC. ALL OTHER EQUIPMENT CONNECTED TO THE BUS CABLE HAS TO BE PASSIVE, MEANING THAT THEY ARE NOT ALLOWED TO PROVIDE ENERGY TO THE SYSTEM, EXCEPT FOR A LEAKAGE CURRENT OF 50  $\mu$ A FOR EACH CONNECTED DEVICE. SEPARATELY POWERED EQUIPMENT NEEDS A GALVANIC ISOLATION TO ASSURE THAT THE INTRINSICALLY SAFE FIELDBUS CIRCUIT REMAINS PASSIVE.

THE CABLE USED TO CONNECT THE DEVICES NEEDS TO HAVE THE PARAMETERS IN THE FOLLOWING RANGE:

LOOP RESISTANCE R': 15 TO 150 ohms/km  
INDUCTANCE PER UNIT LENGTH L: 0.4 TO 1 mH/km  
CAPACITANCE PER UNIT LENGTH C': 80 TO 200 nF/km  
 $C' = C' \text{ LINE/LINE} + 0.5' \text{ LINE/SCREEN}$ , IF BOTH LINES ARE FLOATING OR  
 $C' = C' \text{ LINE/LINE} + C' \text{ LINE/SCREEN}$ , IF THE SCREEN IS CONNECTED TO ONE LINE.  
LENGTH OF SPLICE: < 1 m (T-BOX MUST ONLY CONTAIN TERMINAL CONNECTIONS WITH NO ENERGY STORAGE CAPABILITY)  
LENGTH OF SPUR CABLE: < 30 M  
LENGTH OF TRUNK CABLE: < 1 km

AT EACH END OF THE TRUNK CABLE AN APPROVED INFALLIBLE TERMINATION WITH THE FOLLOWING PARAMETERS IS SUITABLE:

$$R = 90 \text{ TO } 100 \text{ ohms AND } C = 0 \text{ TO } 2.2 \text{ }\mu\text{F}$$

NOTE, A BUILT-IN TERMINATOR IS INCLUDED IN THE FIELD SIDE AND A SELECTABLE TERMINATOR IS AVAILABLE ON THE HOST SIDE.

THE NUMBER OF PASSIVE DEVICES CONNECTED TO THE BUS SEGMENT IS NOT LIMITED IN THE FISCO CONCEPT FOR INTRINSICALLY SAFE REASONS. IF THE ABOVE RULES ARE RESPECTED, UP TO A TOTAL LENGTH OF 1000 m (SUM OF THE LENGTH OF THE TRUNK CABLE AND ALL SPUR CABLES), THE INDUCTANCE AND CAPACITANCE OF THE CABLE WILL NOT IMPAIR THE INTRINSIC SAFETY OF THE INSTALLATION.

③ INSTALLATION MUST BE IN ACCORDANCE WITH THE NATIONAL WIRING PRACTICES OF THE COUNTRY IN USE.

④ LOOPS MUST BE CONNECTED ACCORDING TO THE BARRIER MANUFACTURER'S INSTRUCTIONS.

⑤ IF HAND-HELD COMMUNICATOR OR MULTIPLEXER IS USED, IT MUST BE IECEx APPROVED WITH ENTITY PARAMETERS AND INSTALLED PER THE MANUFACTURER'S CONTROL DRAWINGS.

Scan or click the appropriate  
QR code for digital valve  
controller field support



DVC6200 SIS



DVC6200p



DVC6200



DVC6200f

Neither Emerson, Emerson Process Management, nor any of their affiliated entities assumes responsibility for the selection, use or maintenance of any product. Responsibility for proper selection, use, and maintenance of any product remains solely with the purchaser and end user.

Fisher, FIELDVUE, ValveLink, and THUM are marks owned by one of the companies in the Emerson Process Management business unit of Emerson Electric Co. Emerson Process Management, Emerson, and the Emerson logo are trademarks and service marks of Emerson Electric Co. HART and the HART logo are registered trademarks of FieldComm Group. FOUNDATION fieldbus and the Fieldbus logo are trademarks of FieldComm Group. The PROFIBUS logo is a mark owned by PROFIBUS Nutzerorganisation e.V. All other marks are the property of their respective owners.

The contents of this publication are presented for informational purposes only, and while every effort has been made to ensure their accuracy, they are not to be construed as warranties or guarantees, express or implied, regarding the products or services described herein or their use or applicability. All sales are governed by our terms and conditions, which are available upon request. We reserve the right to modify or improve the designs or specifications of such products at any time without notice.

Emerson Process Management  
Marshalltown, Iowa 50158 USA  
Sorocaba, 18087 Brazil  
Chatham, Kent ME4 4QZ UK  
Dubai, United Arab Emirates  
Singapore 128461 Singapore

[www.Fisher.com](http://www.Fisher.com)