

Fisher™ FIELDVUE™ DVC6200f Digital Valve Controller - PST Instrument Level

The FIELDVUE DVC6200f digital valve controller is a FOUNDATION™ Fieldbus communicating instrument that converts a digital control signal into a pneumatic output to an actuator. The DVC6200f PST instrument level enables on-line partial stroke valve testing, which can be used in conjunction with a SIL capable solenoid valve (SOV) to provide additional diagnostic coverage to the SIS valve assembly. It can easily be retrofitted in place of existing analog positioners on most Fisher and non-Fisher pneumatic actuators.

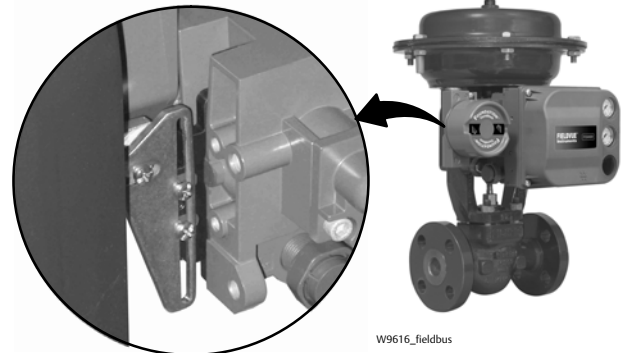

LINKAGE-LESS
FEEDBACK SYSTEM

Features

Reliability

- **Linkage-Less Non-Contact Position Feedback**—The high performance, linkage-less feedback system eliminates physical contact between the valve stem and the DVC6200f. There are no wearing parts so cycle life is maximized.
- **Built to Survive**—The field proven DVC6200f instrument has fully encapsulated electronics that resist the effects of vibration, temperature, and corrosive atmospheres. A weather-tight wiring terminal box isolates field wiring connections from other areas of the instrument.
- **Increased Process Uptime**—The DVC6200f instrument reduces the risk of spurious trip on loss of segment power by using a reverse acting relay.

Performance

- **Accurate and Responsive**—The two-stage positioner design provides quick response to large step changes and precise control for small setpoint changes.

- **Travel Control/Pressure Fallback**—Valve position feedback is critical to the operation of a digital valve controller. The DVC6200f can detect position feedback problems and automatically revert to pneumatic control mode to keep the valve operational.

Shutdown Valve Stroke Testing

- **Partial Stroke Testing (PST)**—An on-line diagnostic to detect valve failure modes such as stuck valve by performing a small ramp test that moves the valve, without disrupting the process. Testing can be automated or initiated manually.
- **Full Stroke Testing (FST)**—An off-line diagnostic test to reveal additional valve failure modes undetected by the PST by performing a full ramp over the entire valve travel range. FST is typically performed during a shut down.
- **FF906 Certified**—Partial and full stroke tests can be initiated from any host which supports the FOUNDATION Fieldbus standard FF-906 Specification.

Figure 1. Condition Indicators

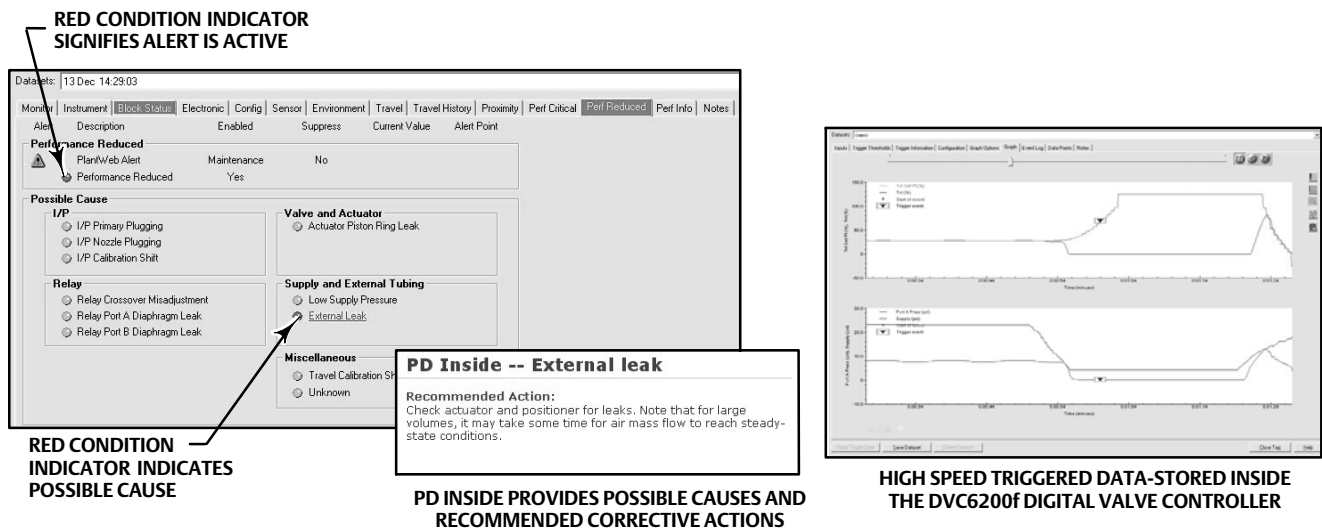

Ease of Use

- **Enhanced Personnel Safety**—Valve diagnostic information can be accessed anywhere along the communication loop, reducing personnel exposure to hazardous environments or difficult to reach locations.
- **Faster Commissioning**—FOUNDATION Fieldbus communications allows you to quickly commission loops with a variety of tools, either locally at the valve assembly or remotely.
- **Easy Maintenance**—The DVC6200f digital valve controller is modular in design. Critical working components can be replaced without removing field wiring or pneumatic tubing.
- **Hassle-free diagnostics**—Partial stroke and full stroke tests result in an easy to understand Pass/Abnormal criteria including reason for any Abnormal result

Value

- **Hardware Savings**—When installed in an integrated control system, significant hardware and installation cost savings can be achieved. Valve accessories such as limit switches and position transmitters can be eliminated because this information is available as function blocks.

- **Increased Uptime**—The self-diagnostic capability of the DVC6200f digital valve controller provides valve performance and health evaluation without shutting down the process or pulling the valve assembly from the line.
- **Improved Maintenance Decisions**—Digital communication provides easy access to the condition of the valve. The DVC6200f alerts comply with the FOUNDATION Fieldbus specifications for Field Diagnostics. Sound process and asset management decisions can be made by analysis of valve information through Fisher ValveLink™ software.
- **Audit Documentation**—The device provides a time and date stamp on all tests allowing the means to comply with requirements of statutory authorities.

- **Block Instantiation**—The DVC6200f supports the use of Function Block Instantiation. When a device supports block instantiation, the number of blocks and block types can be customized to match specific application needs. Block Instantiation does not apply to standard device blocks such as Resource and Transducer Blocks.

Valve Diagnostics

The DVC6200f digital valve controller provides a broad and deep portfolio of valve diagnostic capabilities. Whether the 475 Field Communicator is used to check for valve alerts and operational status, or ValveLink software is used for comprehensive diagnostic test and analysis, the tools are easy to use. Because the FOUNDATION Fieldbus system provides continuous digital communication to field devices, the DVC6200f delivers prompt notification of current or potential equipment issues.

The DVC6200f captures the stroke history when a demand stroke or return stroke occurs. The data is date and time stamped.

Partial Stroke Test (PST) enables valves that are in one position to be ramped as far as the process will tolerate to detect a stuck valve. The results are date and time stamped and stored in the device, available for upload by ValveLink software.

Means to prevent spurious trips are included with the DVC6200f PST instrument level, including an outgoing pressure threshold that will abort the partial stroke test if exceeded. This prevents a sticking valve and actuator from overtraveling and potentially causing a spurious trip.

Additionally, the DVC6200f PST instrument level provides access to all the capabilities of Performance Diagnostics (PD). Performance Diagnostics (PD) enable condition and performance monitoring of the entire valve assembly (not just the digital valve controller) while the valve is actively controlling the process. When conducting Performance Diagnostics tests, the valve does NOT move beyond the normal setpoint changes driven by the process controller. The DVC6200f uses statistical algorithms to determine condition and performance related issues based on live readings from the many on-board sensors. Results are then displayed graphically, with severity indicated. A detailed description of the identified issue as well as suggestions for recommended actions are provided, as shown in figure 1.

Examples of identifiable issues are:

- Valve Stuck
- Solenoid Stuck
- Low air supply or pressure droop
- Incorrect regulator setting
- Dirty air supply
- External air leak (actuator diaphragm or tubing)
- Calibration shift
- Piston actuator O-ring failure
- Excessive or insufficient valve assembly friction
- Excessive valve assembly deadband
- Elastomer failure in the DVC6200f
- Broken actuator spring
- Broken valve/actuator shaft

Performance Diagnostics also provide access to full-stroke dynamic testing of the valve assembly including; valve signature, dynamic error band, step response, and stroke check. These tests change the instrument setpoint at a controlled rate and are performed while the valve assembly is isolated from the process.

For additional information on FIELDVUE diagnostics and ValveLink software refer to Fisher bulletin 62.1:ValveLink Software ([D102227X012](#)).

Solenoid Valve Health Monitoring

If a solenoid valve is installed between the DVC6200f pressure output and the actuator, as shown in figure 2, the valve assembly can be configured to verify the operation of the solenoid valve during online operation. In single-acting actuator applications, the “unused” output port of the DVC6200f can be piped such that the pressure downstream of the of solenoid valve is measured. When the solenoid valve is pulsed, the DVC6200f can sense the momentary pressure drop across the solenoid valve. The solenoid should be pulsed long enough to detect a pressure drop across the solenoid valve, but not so long that it affects the travel of the final control element. This can increase the availability of the solenoid valve during a safety demand and can also enhance the reliability of the SIF (Safety Instrumented Function) loop.

Figure 2. Solenoid Valve Testing

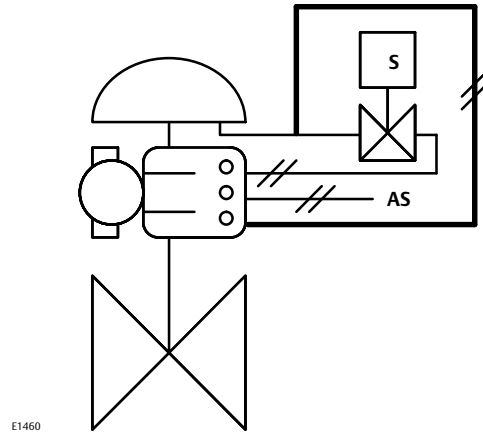

E1460

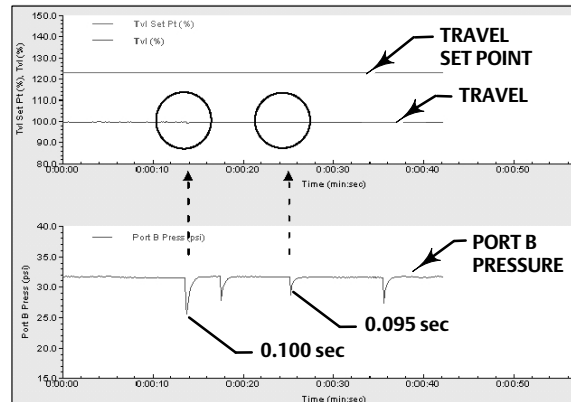

E1028

ValveLink Software Screen Image Showing Pressure Drop Across the Solenoid Valve

Application Examples

Figure 3. De-Energize to Trip (DETT) FIELDVUE DVC6200f and Solenoid Valve

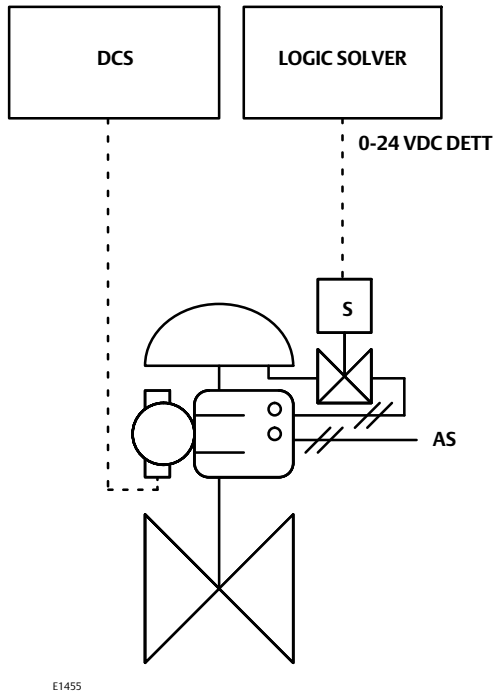

Benefits

- DVC6200f provides diagnostic coverage with PST
- DVC6200f can provide additional diagnostic coverage when optional solenoid pulse recording is utilized
- The DVC6200f is capable of recording the demand and reset stroke of the valve

Operation

- DVC6200f will move to the safety demand state upon loss of power or loss of pneumatic supply
- The DVC6200f can be configured to move to the safety demand state upon loss of communication signal
- The solenoid valve will move the valve to the safety demand state

Figure 4. FIELDVUE DVC6200f Energize to Trip (ETT) and Solenoid Valve

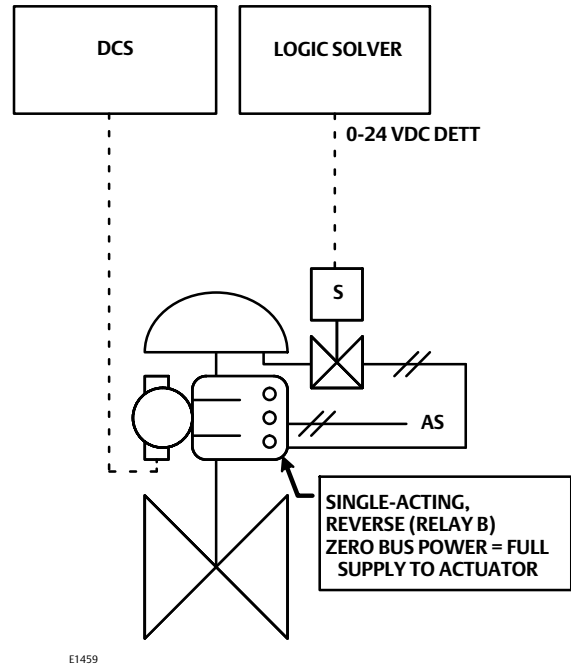

Benefits

- The energize to trip option provides maximum actuator pressure when power to the instrument is lost. Therefore, loss of power to the instrument will not cause the valve to trip.
- DVC6200f can provide additional diagnostics coverage when performing PST
- DVC6200f can provide additional diagnostic coverage when optional solenoid pulse recording is utilized

Operation

- DVC6200f will move to the safety demand state upon command or loss of pneumatic supply
- The solenoid valve will move the valve to the safety demand state

Specifications

Available Mounting

- Sliding-stem linear applications
- Quarter-turn rotary applications
- Integral mounting to Fisher 657/667 or GX actuators
- Integral mounting to Fisher rotary actuators,

DVC6200f digital valve controllers can also be mounted on other actuators that comply with IEC 60534-6-1, IEC 60534-6-2, VDI/VDE 3845 and NAMUR mounting standards

Instrument Blocks

Resource Block

Transducer Block complies with FOUNDATION Fieldbus specification FF-906 for valve stroke testing

Function Block Suites

- SC (Standard Control) - throttling control
Includes AO, PID, ISEL, OS, AI, MAI, DO, CSEL, and DI function blocks
- FC (Fieldbus Control) - throttling control
Contains the AO function block
- FL (Fieldbus Logic) - discrete (on/off) connectivity
Includes DO, and DI function blocks

Function Block Instantiation

If a host system supports block instantiation, a maximum of 20 function blocks can be instantiated in the device at any given time from the available function blocks, which may include AO (1), DO (1), AI (4), DI (6), MAI (1), PID (4), OS (3), ISEL (2), CSEL (2)

Note: Only the function blocks available in the function block suite can be instantiated by the host system

Function Block Execution Times

AO Block: 20 ms	MAI Block: 35 ms
PID Block: 20 ms	DO Block: 20 ms
ISEL Block: 20 ms	DI Block: 15 ms
OS Block: 20 ms	CSEL Block: 15 ms
AI Block: 20 ms	

Electrical Input

Voltage Level: 9 to 32 volts
Maximum Current: 19 mA

Reverse Polarity Protection: Unit is not polarity sensitive

Termination: Bus must be properly terminated per ISA SP50 guidelines

Digital Communication Protocol

FOUNDATION Fieldbus registered device

Physical Layer Type(s):

121: Low-power signaling, bus-powered, Entity Model I.S.

511: Low-power signaling, bus-powered, FISCO I.S.

Fieldbus Device Capabilities

Backup LAS (Link Active Scheduler)

Supply Pressure⁽¹⁾

Minimum Recommended: 0.3 bar (5 psig) higher than maximum actuator requirements

Maximum: 10.0 bar (145 psig) or maximum pressure rating of the actuator, whichever is lower

Supply Medium

Air or Natural Gas

Supply medium must be clean, dry, and noncorrosive and meet the requirements of ISA Standard 7.0.01 or ISO 8573-1

Output Signal

Pneumatic signal, up to full supply pressure

Minimum Span: 0.4 bar (6 psig)

Maximum Span: 9.5 bar (140 psig)

Action: ■ Double, ■ Single Direct or ■ Reverse

Steady-State Air Consumption⁽²⁾⁽³⁾

At 1.4 bar (20 psig) supply pressure:

Less than 0.38 normal m³/hr (14 scfh)

At 5.5 bar (80 psig) supply pressure:

Less than 1.3 normal m³/hr (49 scfh)

Maximum Output Capacity⁽²⁾⁽³⁾

At 1.4 bar (20 psig) supply pressure:

10.0 normal m³/hr (375 scfh)

At 5.5 bar (80 psig) supply pressure:

29.5 normal m³/hr (1100 scfh)

-continued-

Specifications (continued)

Operating Ambient Temperature Limits⁽¹⁾⁽⁴⁾

-40 to 85°C (-40 to 185°F)
-52 to 85°C (-62 to 185°F) for instruments utilizing the Extreme Temperature option (fluorosilicone elastomers)

Independent Linearity⁽⁵⁾

Typical Value: $\pm 0.50\%$ of output span

Electromagnetic Compatibility

Meets EN 61326-1:2013
Immunity—Industrial locations per Table 2 of the EN 61326-1 standard.
Emissions—Class A
ISM equipment rating: Group 1, Class A

Vibration Testing Method

Tested per ANSI/ISA-S75.13.01 Section 5.3.5.

Humidity Testing Method

Tested per IEC 61514-2

Electrical Classification

Hazardous Area Approvals

CSA— Intrinsicly Safe, FISCO, Explosion-proof, Division 2, Dust Ignition-proof

FM— Intrinsicly Safe, FISCO, Explosion-proof, Non-Incendive, Dust Ignition-proof

ATEX— Intrinsicly Safe, FISCO, Flameproof, Type n, Dust by intrinsic safety

IECEX— Intrinsicly Safe, FISCO, Flameproof, Type n, Dust by intrinsic safety or by enclosure

Electrical Housing

CSA— Type 4X, IP66

FM— Type 4X, IP66

ATEX— IP66

IECEX— IP66

Other Classifications/Certifications

IEC61508 Functional Safety Certifications— Not applicable, for diagnostic use only in conjunction with appropriate SIL capable solenoid valve (SOV)

Natural Gas Certified, Single Seal Device— CSA, FM, ATEX, and IECEX

Lloyds Register— Marine Type Approval

CUTR— Customs Union Technical Regulations (Russia, Kazakhstan, Belarus, and Armenia)

INMETRO— National Institute of Metrology, Quality and Technology (Brazil)

KGS— Korea Gas Safety Corporation (South Korea)

NEPSI— National Supervision and Inspection Centre for Explosion Protection and Safety of Instrumentation (China)

PESO CCOE— Petroleum and Explosives Safety Organisation - Chief Controller of Explosives (India)

TIIS— Technology Institution of Industrial Safety (Japan)

Contact your [Emerson Automation Solutions sales office](#) for classification/certification specific information



Connections

Supply Pressure: 1/4 NPT internal and integral pad for mounting 67CFR regulator

Output Pressure: 1/4 NPT internal

Tubing: 3/8-inch recommended

Vent: 3/8 NPT internal

Electrical: 1/2 NPT internal or M20⁽⁶⁾

Actuator Compatibility

Stem Travel (Sliding-Stem Linear)

Minimum: 6.35 mm (0.25 inch)

Maximum: 606 mm (23-7/8 inches)

Shaft Rotation (Quarter-Turn Rotary)

Minimum: 45°

Maximum: 90°

Weight

Aluminum: 3.5 kg (7.7 lbs)

Stainless Steel: 8.6 kg (19 lbs)

-continued-

Specifications (continued)

Construction Materials

Housing, module base and terminal box
A03600 low copper aluminum alloy (standard),
Stainless Steel (optional)
Cover: Thermoplastic polyester
Elastomers: Nitrile (standard)

Options

■ Supply and output pressure gauges or ■ Tire valves

■ Integral mounted filter regulator ■ Low-Bleed
Relay ■ Extreme Temperature ■ Natural Gas
Certified, Single Seal Device ■ Remote Mount⁽⁷⁾
■ Stainless Steel ■ LCP200 Local Control Panel

Additional Information

For additional information go to www.FIELDVUE.com
or contact your [Emerson Automation Solutions sales office](#).

NOTE: Specialized instrument terms are defined in ANSI/ISA Standard 51.1 - Process Instrument Terminology.

1. The pressure/temperature limits in this document and any other applicable code or standard should not be exceeded.

2. Normal m³/hour - Normal cubic meters per hour at 0°C and 1.01325 bar, absolute. Scfh - Standard cubic feet per hour at 60°F and 14.7 psia.

3. Values at 1.4 bar (20 psig) based on a single-acting direct relay; values at 5.5 bar (80 psig) based on double-acting relay.

4. Temperature limits vary based on hazardous area approval.

5. Not applicable for travels less than 19 mm (0.75 inch) or for shaft rotation less than 60 degrees. Also not applicable for digital valve controllers in long-stroke applications.

6. M20 electrical connection only available with ATEX approvals.

7. 4-conductor shielded cable, 18 to 22 AWG minimum wire size, in rigid or flexible metal conduit, is required for connection between base unit and feedback unit.

Neither Emerson, Emerson Automation Solutions, nor any of their affiliated entities assumes responsibility for the selection, use or maintenance of any product. Responsibility for proper selection, use, and maintenance of any product remains solely with the purchaser and end user.

Fisher, FIELDVUE, and ValveLink are marks owned by one of the companies in the Emerson Automation Solutions business unit of Emerson Electric Co. Emerson Automation Solutions, Emerson, and the Emerson logo are trademarks and service marks of Emerson Electric Co. FOUNDATION Fieldbus is a trademark of FieldComm Group. All other marks are the property of their respective owners.

The contents of this publication are presented for informational purposes only, and while every effort has been made to ensure their accuracy, they are not to be construed as warranties or guarantees, express or implied, regarding the products or services described herein or their use or applicability. All sales are governed by our terms and conditions, which are available upon request. We reserve the right to modify or improve the designs or specifications of such products at any time without notice.

Emerson Automation Solutions
Marshalltown, Iowa 50158 USA
Sorocaba, 18087 Brazil
Cernay, 68700 France
Dubai, United Arab Emirates
Singapore 128461 Singapore

www.Fisher.com

