

# Fisher™ FIELDVUE™ DVC6200f Digital Valve Controller

The FIELDVUE DVC6200f digital valve controller is a FOUNDATION™ Fieldbus communicating instrument that converts a digital control signal into a pneumatic output to an actuator. It can easily be retrofitted in place of existing analog positioners on most Fisher and non-Fisher pneumatic actuators.

## Features

### Reliability

- **Linkage-Less Non-Contact Position Feedback**— The high performance, linkage-less feedback system eliminates physical contact between the valve stem and the DVC6200f. There are no wearing parts so cycle life is maximized.
- **Built to Survive**— The field proven DVC6200f has fully encapsulated electronics that resist the effects of vibration, temperature, and corrosive atmospheres. A weather-tight wiring terminal box isolates field wiring connections from other areas of the instrument.

### Performance

- **Accurate and Responsive**— The two-stage positioner design provides quick response to large step changes and precise control for small setpoint changes.

### Ease of Use

- **Enhanced Safety**— The DVC6200f is a FOUNDATION Fieldbus communicating device, so information can be accessed anywhere along the loop. This flexibility can reduce exposure to hazardous environments and make it easier to evaluate valves in hard to reach locations.
- **Faster Commissioning**— FOUNDATION Fieldbus communications allows you to quickly commission loops with a variety of tools, either locally at the valve assembly or remotely.

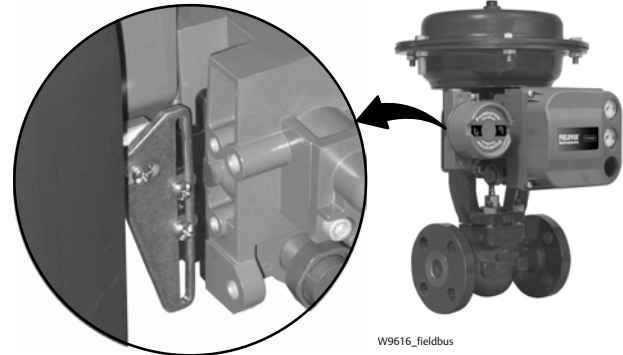

LINKAGE-LESS  
FEEDBACK SYSTEM

- **Easy Maintenance**— The DVC6200f is modular in design. Critical working components can be replaced without removing field wiring or pneumatic tubing.

### Value

- **Hardware Savings**— When installed in an integrated control system, significant hardware and installation cost savings can be achieved. Valve accessories such as limit switches and position transmitters can be eliminated because this information is available through the function blocks.
- **Increased Uptime**— The self-diagnostic capability of the DVC6200f provides valve performance and health evaluation without shutting down the process or pulling the valve assembly from the line.
- **Improved Maintenance Decisions**— Digital communication provides easy access to the condition of the valve. Sound process and asset management decisions can be made by analysis of valve information through Fisher ValveLink™ software.

Figure 1. Status Monitor

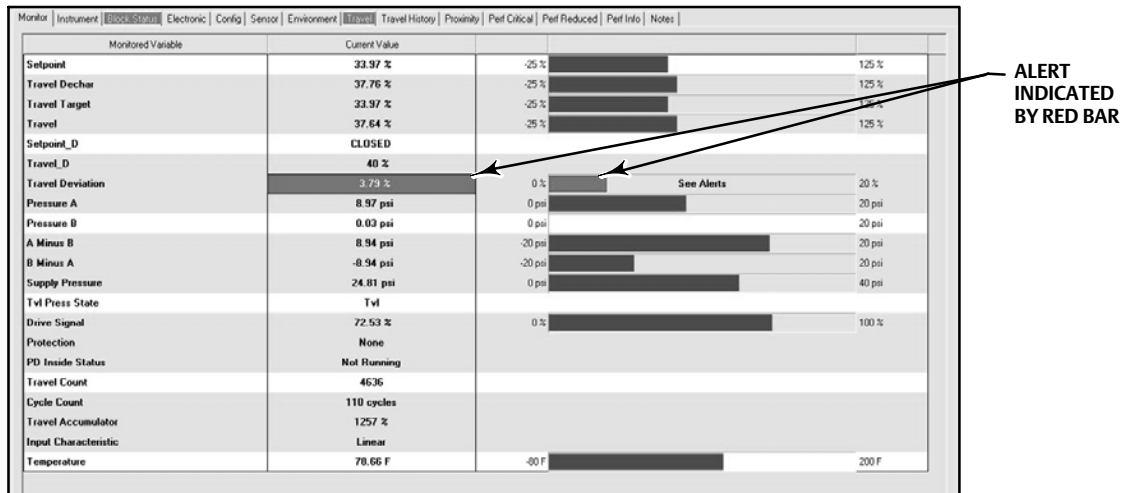

- **Block Instantiation**—The DVC6200f supports the use of Function Block Instantiation. When a device supports block instantiation, the number of blocks and block types can be customized to match specific application needs. Block Instantiation does not apply to standard device blocks such as Resource and Transducer Blocks.

**Notes**

Block instantiation must be supported by the host system.

Only the function blocks available in the function block suite can be instantiated by the host system.

A maximum of 20 function blocks can be instantiated in the device at any given time from the available function blocks, which may include AO (1), DO (1), AI (4), DI (6), MAI (1), PID (4), OS (3), ISEL (2), CSEL (2).

## Valve Diagnostics

The DVC6200f digital valve controller provides a comprehensive library of valve diagnostic alerts. These alerts are easily accessed with the 475 Field Communicator. When installed as part of a FOUNDATION Fieldbus communicating system the DVC6200f delivers prompt notification of current or potential equipment issues directly to the asset management system and supports Field Diagnostics.

Alerts assist in identification and notification of the following situations:

- Valve travel deviation due to excessive valve friction or galling (see figure 1)
- High cycle due to dither or improper tuning
- Total travel movement has accumulated beyond a specified point resulting in packing wear
- Valve travel is above or below a specified point
- Various instrument mechanical and electrical issues

For additional information on FIELDVUE diagnostics and ValveLink software refer to Fisher bulletin 62.1:ValveLink Software ([D102227X012](#)).

## Specifications

### Available Mounting

- Integral mounting to Fisher 657/667 or GX actuators
- Integral mounting to Fisher rotary actuators,
- Sliding-stem linear applications
- Quarter-turn rotary applications

DVC6200f digital valve controllers can also be mounted on other actuators that comply with IEC 60534-6-1, IEC 60534-6-2, VDI/VDE 3845 and NAMUR mounting standards

### Function Block Suites

- SC (Standard Control) (throttling control)  
Includes AO, PID, ISEL, OS, AI, MAI, DO, CSEL, and DI function blocks
- FC (Fieldbus Control) (throttling control)  
Contains the AO function block
- FL (Fieldbus Logic) [discrete (on/off) connectivity]  
Includes DO and DI function blocks

### Block Execution Times

AO Block: 20 ms	MAI Block: 35 ms
PID Block: 20 ms	DO Block: 20 ms
ISEL Block: 20 ms	DI Block: 15 ms
OS Block: 20 ms	CSEL Block: 15 ms
AI Block: 20 ms	

### Electrical Input

Voltage Level: 9 to 32 volts  
Maximum Current: 19 mA  
Reverse Polarity Protection: Unit is not polarity sensitive  
Termination: Bus must be properly terminated per ISA SP50 guidelines

### Digital Communication Protocol

FOUNDATION Fieldbus registered device

Physical Layer Types(s):

- 121: Low-power signaling, bus-powered, Entity Model I.S.
- 511: Low-power signaling, bus-powered, FISCO I.S.

### Fieldbus Device Capabilities

Backup LAS (Link Active Scheduler)

### Supply Pressure<sup>(1)</sup>

Minimum Recommended: 0.3 bar (5 psig) higher than maximum actuator requirements

Maximum: 10.0 bar (145 psig) or maximum pressure rating of the actuator, whichever is lower

### Supply Medium

Air or Natural Gas

Supply medium must be clean, dry, and noncorrosive and meet the requirements of ISA Standard 7.0.01 or ISO 8573-1

### Output Signal

Pneumatic signal, up to full supply pressure  
Minimum Span: 0.4 bar (6 psig)  
Maximum Span: 9.5 bar (140 psig)  
Action: ■ Double, ■ Single Direct or ■ Reverse

### Steady-State Air Consumption<sup>(2)(3)</sup>

At 1.4 bar (20 psig) supply pressure: Less than 0.38 normal m<sup>3</sup>/hr (14 scfh)  
At 5.5 bar (80 psig) supply pressure: Less than 1.3 normal m<sup>3</sup>/hr (49 scfh)

### Maximum Output Capacity<sup>(2)(3)</sup>

At 1.4 bar (20 psig) supply pressure: 10.0 normal m<sup>3</sup>/hr (375 scfh)  
At 5.5 bar (80 psig) supply pressure: 29.5 normal m<sup>3</sup>/hr (1100 scfh)

### Operating Ambient Temperature Limits<sup>(1)(4)</sup>

-40 to 85°C (-40 to 185°F)  
-52 to 85°C (-62 to 185°F) for instruments utilizing the Extreme Temperature option (fluorosilicone elastomers)

### Independent Linearity<sup>(5)</sup>

Typical Value: ±0.50% of output span

### Electromagnetic Compatibility

Meets EN 61326-1:2013  
Immunity—Industrial locations per Table 2 of the EN 61326-1 standard.  
Emissions—Class A  
ISM equipment rating: Group 1, Class A

### Vibration Testing Method

Tested per ANSI/ISA-S75.13.01 Section 5.3.5.

### Humidity Testing Method

Tested per IEC 61514-2

-continued-

Specifications (continued)

Electrical Classification

Hazardous Area Approvals

CSA— Intrinsicly Safe, FISCO, Explosion-proof, Division 2, Dust Ignition-proof

FM— Intrinsicly Safe, FISCO, Explosion-proof, Non-Incendive, Dust Ignition-proof

ATEX— Intrinsicly Safe, FISCO, Flameproof, Type n, Dust by intrinsic safety

IECEX— Intrinsicly Safe, FISCO, Flameproof, Type n, Dust by intrinsic safety or by enclosure

Electrical Housing

CSA— Type 4X, IP66                      ATEX— IP66

FM— Type 4X, IP66                      IECEX— IP66

Other Classifications/Certifications

Natural Gas Certified, Single Seal Device— CSA, FM, ATEX, and IECEX

Lloyds Register— Marine Type Approval

CUTR— Customs Union Technical Regulations (Russia, Kazakhstan, Belarus, and Armenia)

INMETRO— National Institute of Metrology, Quality and Technology (Brazil)

KGS— Korea Gas Safety Corporation (South Korea)

NEPSI— National Supervision and Inspection Centre for Explosion Protection and Safety of Instrumentation (China)

PESO CCOE— Petroleum and Explosives Safety Organisation - Chief Controller of Explosives (India)

TIIS— Technology Institution of Industrial Safety (Japan)

Contact your [Emerson Automation Solutions sales office](#) for classification/certification specific information

Connections

Supply Pressure: 1/4 NPT internal and integral pad for mounting 67CFR regulator

Output Pressure: 1/4 NPT internal

Tubing: 3/8-inch recommended

Vent: 3/8 NPT internal

Electrical: 1/2 NPT internal or M20<sup>(6)</sup>

Actuator Compatibility

Stem Travel (Sliding-Stem Linear)

Minimum: 6.35 mm (0.25 inch)

Maximum: 606 mm (23-7/8 inches)

Shaft Rotation (Quarter-Turn Rotary)

Minimum: 45°

Maximum: 90°

Weight

Aluminum: 3.5 kg (7.7 lbs)

Stainless Steel: 8.6 kg (19 lbs)

Construction Materials

Housing, module base and terminal box:

A03600 low copper aluminum alloy (standard),

Stainless Steel (optional)

Cover: Thermoplastic polyester

Elastomers: Nitrile (standard)

Options

- Supply and output pressure gauges or ■ Tire valves
- Integral mounted filter regulator ■ Low-Bleed Relay
- Extreme Temperature ■ Natural Gas Certified, Single Seal Device ■ Remote Mount<sup>(7)</sup> ■ Stainless Steel

NOTE: Specialized instrument terms are defined in ANSI/ISA Standard 51.1 - Process Instrument Terminology.

1. The pressure/temperature limits in this document and any other applicable code or standard should not be exceeded.

2. Normal m<sup>3</sup>/hour - Normal cubic meters per hour at 0°C and 1.01325 bar, absolute. Scfh - Standard cubic feet per hour at 60°F and 14.7 psia.

3. Values at 1.4 bar (20 psig) based on a single-acting direct relay; values at 5.5 bar (80 psig) based on double-acting relay.

4. Temperature limits vary based on hazardous area approval.

5. Not applicable for travels less than 19 mm (0.75 inch) or for shaft rotation less than 60 degrees. Also not applicable for digital valve controllers

in long-stroke applications.

6. M20 electrical connection only available with ATEX approvals.

7. 4-conductor shielded cable, 18 to 22 AWG minimum wire size, in rigid or flexible metal conduit, is required for connection between base unit and feedback unit.



Scan or click to access sales office information

Neither Emerson, Emerson Automation Solutions, nor any of their affiliated entities assumes responsibility for the selection, use or maintenance of any product. Responsibility for proper selection, use, and maintenance of any product remains solely with the purchaser and end user.

FIELDVUE, Fisher, and ValveLink are marks owned by one of the companies in the Emerson Automation Solutions business unit of Emerson Electric Co. Emerson Automation Solutions, Emerson, and the Emerson logo are trademarks and service marks of Emerson Electric Co. FOUNDATION Fieldbus is a trademark of FieldComm Group. All other marks are the property of their respective owners.

The contents of this publication are presented for informational purposes only, and while every effort has been made to ensure their accuracy, they are not to be construed as warranties or guarantees, express or implied, regarding the products or services described herein or their use or applicability. All sales are governed by our terms and conditions, which are available upon request. We reserve the right to modify or improve the designs or specifications of such products at any time without notice.

Emerson Automation Solutions  
Marshalltown, Iowa 50158 USA  
Sorocaba, 18087 Brazil  
Cernay, 68700 France  
Dubai, United Arab Emirates  
Singapore 128461 Singapore  
[www.Fisher.com](http://www.Fisher.com)

