

Operating Instructions

Turbimax CUS52D

Turbidity sensor

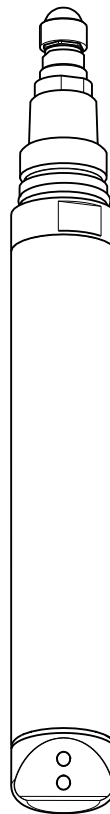

Document information

Warnings

The structure, signal words and safety colors of the signs comply with the specifications of ANSI Z535.6 ("Product safety information in product manuals, instructions and other collateral materials").

Safety message structure	Meaning
⚠ DANGER Causes (/consequences) Consequences if safety message is not heeded ▶ Corrective action	This symbol alerts you to a dangerous situation. Failure to avoid the situation will result in a fatal or serious injury.
⚠ WARNING Causes (/consequences) Consequences if safety message is not heeded ▶ Corrective action	This symbol alerts you to a dangerous situation. Failure to avoid the situation can result in a fatal or serious injury.
⚠ CAUTION Causes (/consequences) Consequences if safety message is not heeded ▶ corrective action	This symbol alerts you to a dangerous situation. Failure to avoid this situation can result in minor or more serious injuries.
NOTICE Cause/situation Consequences if safety message is not heeded ▶ Action/note	This symbol alerts you to situations that can result in damage to property and equipment.

Icons



-  Additional information, tips
-  Permitted or recommended
-  Forbidden or not recommended

Table of contents

1	Basic safety instructions	4	9	Accessories	35
1.1	Requirements for personnel	4	9.1	Assemblies	35
1.2	Designated use	4	9.2	Mounting material	35
1.3	Occupational safety	4	9.3	Holder	36
1.4	Operational safety	4	9.4	Compressed air cleaning	36
1.5	Product safety	5	9.5	Ultrasonic cleaning	36
2	Incoming acceptance and product identification	6	9.6	Bubble trap	37
2.1	Incoming acceptance	6	9.7	Calibration set	37
2.2	Product identification	6	9.8	Transmitter	37
2.3	Scope of delivery	6	10	Technical data	38
2.4	Certificates and approvals	6	10.1	Input	38
3	Installation	7	10.2	Performance characteristics	39
3.1	Dimensions	7	10.3	Environment	40
3.2	Installation instructions	9	10.4	Process	40
3.3	Installation examples	12	10.5	Mechanical construction	40
3.4	Post-installation check	18	Index	42	
4	Electrical connection	19			
4.1	Connecting to the transmitter	19			
4.2	Post-connection check	19			
5	Device description	20			
5.1	Sensor design	20			
5.2	Measuring principle	20			
5.3	Applications	21			
5.4	Calibration	22			
5.5	Cyclic cleaning	30			
5.6	Signal filter	30			
5.7	Calkit CUS52 solid state reference	31			
6	Diagnostics and troubleshooting	32			
7	Maintenance	33			
7.1	Cleaning the sensor	33			
8	Repair	34			
8.1	Spare parts kits	34			
8.2	Return	34			
8.3	Disposal	34			

1 Basic safety instructions

1.1 Requirements for personnel

- ▶ Installation, commissioning, operation and maintenance of the measuring system must only be carried out by specially trained technical personnel.
- ▶ The technical personnel must be authorized for the specified activities by the system operator.
- ▶ Electrical connection must only be carried out by a certified electrician.
- ▶ The technical personnel must have read and understood these Operating Instructions and must follow the instructions they contain.
- ▶ Faults at the measuring point may only be rectified by authorized and specially trained personnel.

 Repairs not described in the enclosed Operating Instructions may only be carried out at the manufacturer's premises or by the Service Organization.

1.2 Designated use

CUS52D is a sensor designed to measure turbidity in drinking water and process water applications.

The sensor is particularly suited for use in the following applications:

- Final turbidity measurement in the outlet of waterworks
- Turbidity measurement in the inlet of waterworks
- Turbidity measurement at all stages of the process
- Turbidity measurement for filter monitoring and filter backwashing
- Turbidity measurement in drinking water networks

Any use other than that described here compromises the safety of persons and the entire measuring system and is, therefore, not permitted.

The manufacturer is not liable for damage resulting from improper or non-designated use.

1.3 Occupational safety

As the user, you are responsible for complying with the following safety conditions:

- Explosion protection guidelines (only devices approved for use in explosion hazardous areas)
- Installation instructions
- Local prevailing standards and regulations

Electromagnetic compatibility

This device has been tested for electromagnetic compatibility in accordance with the applicable European standards for industrial applications.

The electromagnetic compatibility indicated only applies to a device that has been connected in accordance with the instructions in these Operating Instructions.

1.4 Operational safety

- ▶ Before commissioning the entire measuring point, make sure all the connections are correct. Ensure that electrical cables and hose connections are not damaged.
- ▶ Do not operate damaged products, and secure them against unintentional commissioning. Mark the damaged product as defective.
- ▶ If faults cannot be rectified, the products must be taken out of service and secured against unintentional commissioning.

1.5 Product safety

The product is designed to meet state-of-the-art safety requirements, has been tested and left the factory in a condition in which it is safe to operate.

Relevant regulations and European standards have been observed.

2 Incoming acceptance and product identification

2.1 Incoming acceptance

- Make sure the packaging is not damaged.
- Notify the supplier of any damage to the packaging. Keep the damaged packaging until the matter has been settled.
- Make sure the contents are not damaged.
- Notify the supplier of any damage to the delivery contents. Keep the damaged products until the matter has been settled.
- Check the delivery to make sure nothing is missing. Compare it against the shipping documents and your order.
- Pack the product for storage and transportation in such a way that it is reliably protected against impact and moisture. The original packaging offers the best protection. Furthermore, the permitted ambient conditions must also be observed (see "Technical data").
- If you have any questions, contact your supplier or your local sales center.

2.2 Product identification

2.2.1 Nameplate

The nameplate contains the following information:

- Manufacturer details
- Order code
- Extended order code
- Serial number
- Operating conditions
- Safety information symbols

Compare the order code on the nameplate with your order.

2.2.2 Identifying the product

The order code and serial number of your device can be found in the following locations:

- On the nameplate
- In the shipping documents

 To discover what product version you have, enter the order code on the nameplate into the search screen at the following address:
www.products.endress.com/order-ident

2.3 Scope of delivery

The scope of delivery comprises:

- 1 Turbimax CUS52D sensor in the version ordered
- 1 Set of Operating Instructions BA01275C/07/EN

If you have any questions, contact your supplier or your local sales center.

2.4 Certificates and approvals

Declaration of Conformity

The product meets the requirements of the harmonized European standards.

As such, it complies with the legal specifications of the EC directives.

The manufacturer confirms successful testing of the product by affixing to it the **CE** mark.

3 Installation

3.1 Dimensions

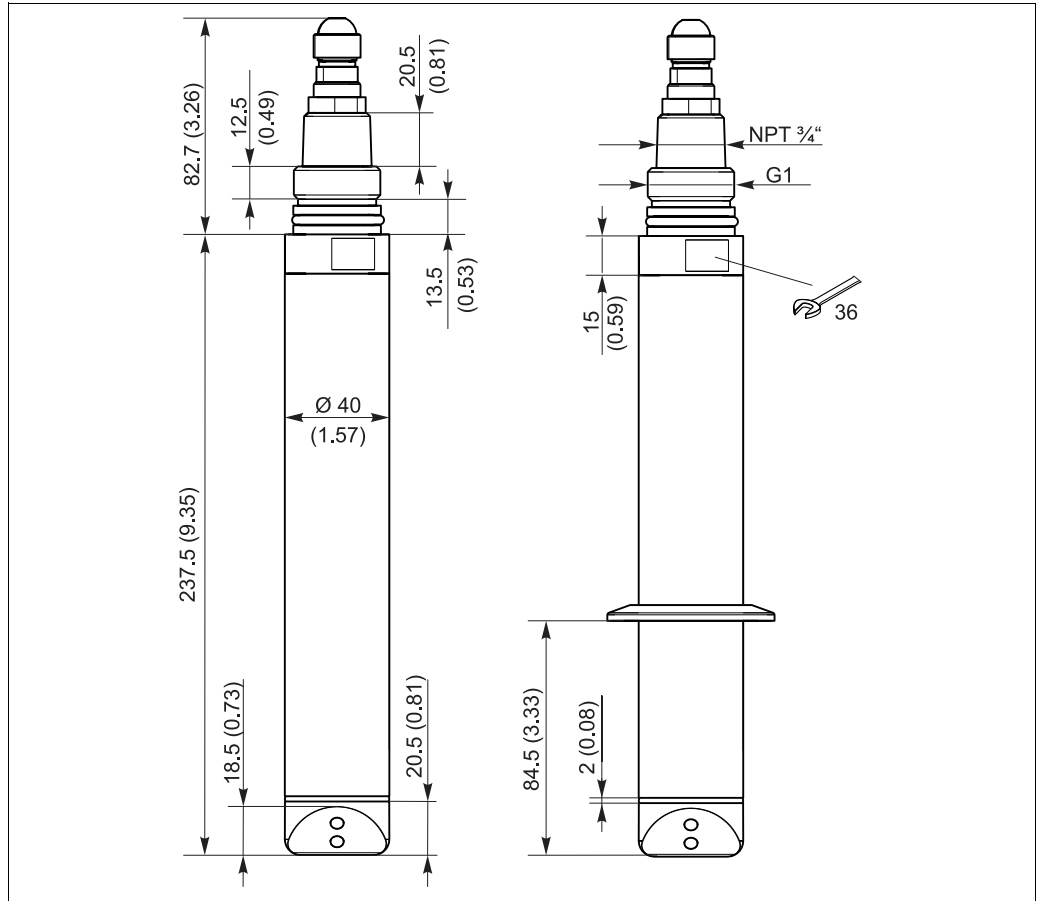

Fig. 1: Dimensions in mm (inch)

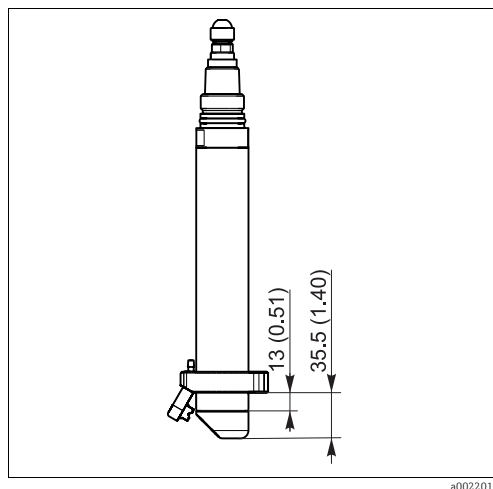

Fig. 2: CUS52D with compressed air cleaning

Compressed air cleaning
 Consumption: 50 l/min (13.2 gal/min)
 Pressure: 1.5 to 2 bar (22 to 30 psi)
 Connection: 6/8 mm or 6.35 mm (1/4")

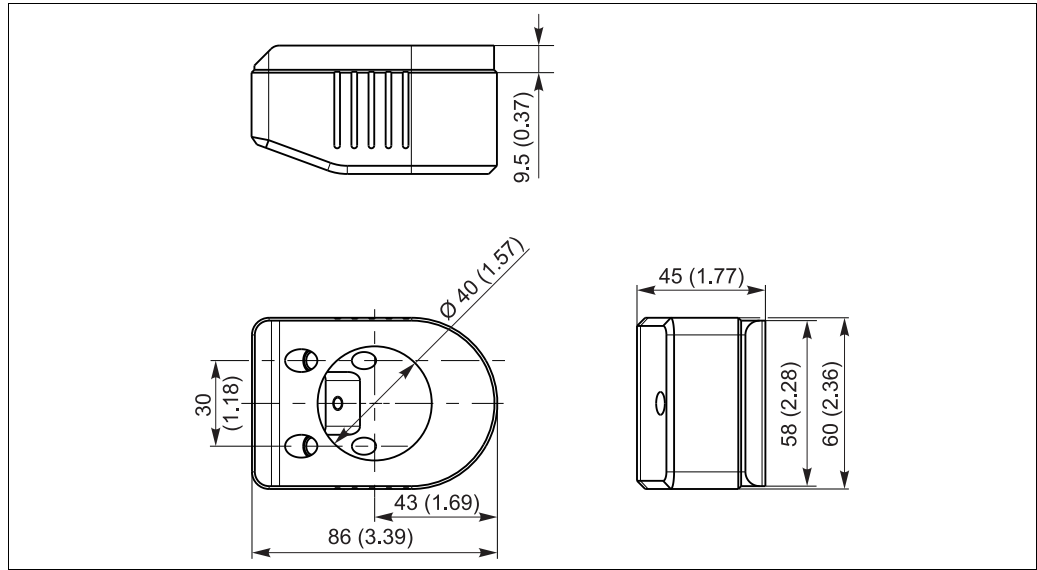

Fig. 3: Calkit CUS52 solid state reference, dimensions in mm (inch)

a0022911

3.2 Installation instructions

3.2.1 Measuring system

A complete measuring system consists of:

- Turbimax CUS52D turbidity sensor
- Liquiline CM44x multichannel transmitter
- Direct installation in a pipe connection (2" clamp) or
- Assembly:
 - CUA252 flow assembly or
 - CUA262 flow assembly or
 - Flexdip CYA112 assembly and Flexdip CYH112 holder system or
 - Retractable assembly, e.g. Cleanfit CUA451

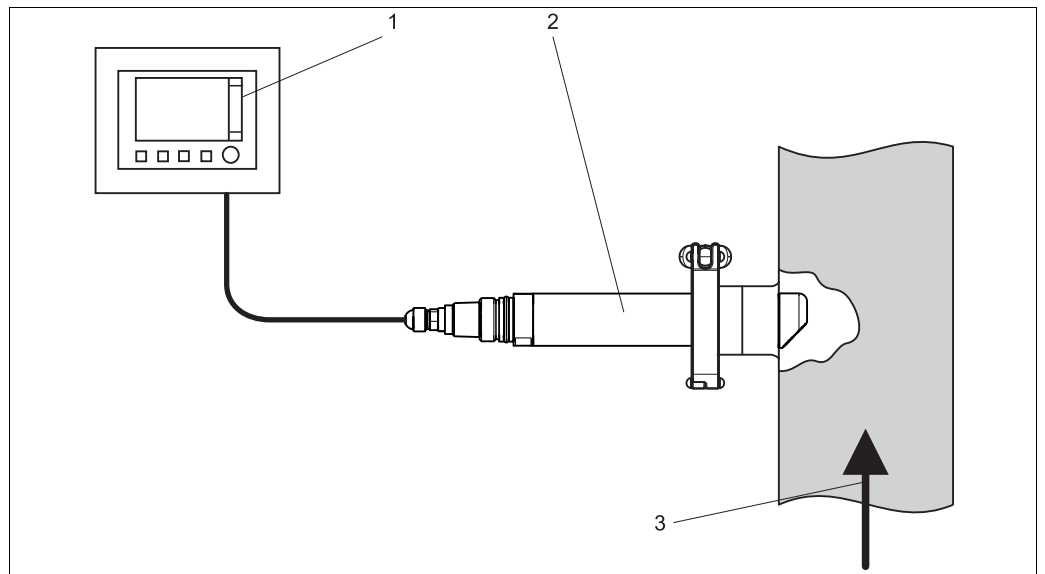

Fig. 4: Direct installation in a pipe connection (2" clamp)

- 1 Liquiline CM44x multichannel transmitter
- 2 Turbimax CUS52D turbidity sensor
- 3 Flow direction

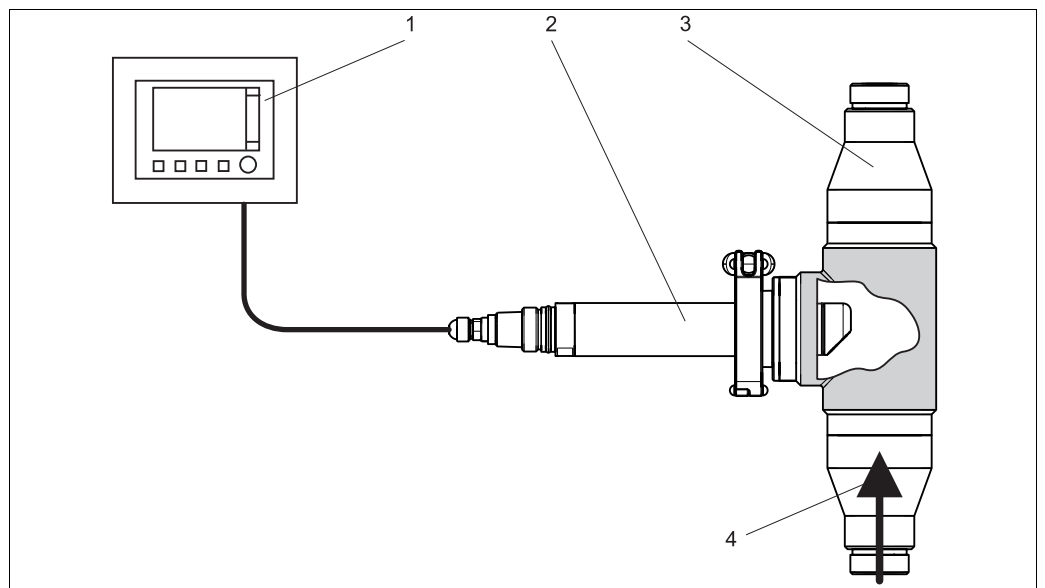
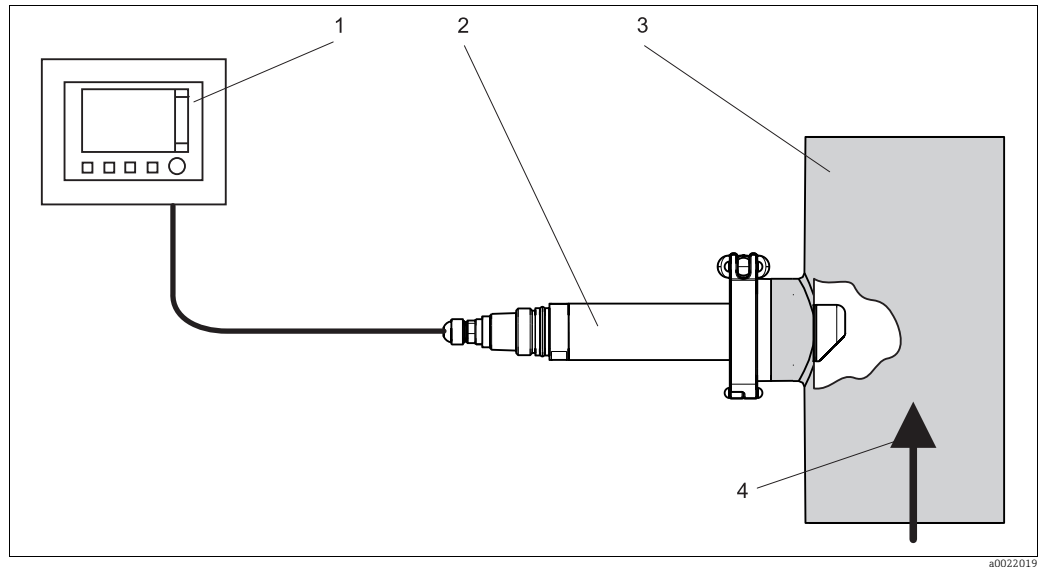

Fig. 5: Measuring system with flow assembly CUA252

- 1 Liquiline CM44x multichannel transmitter
- 2 Turbimax CUS52D turbidity sensor
- 3 CUA252 flow assembly
- 4 Flow direction



a0022019

Fig. 6: Measuring system with flow assembly CUA262

- 1 Liquiline CM44x multichannel transmitter
- 2 Turbimax CUS52D turbidity sensor
- 3 CUA262 flow assembly
- 4 Flow direction

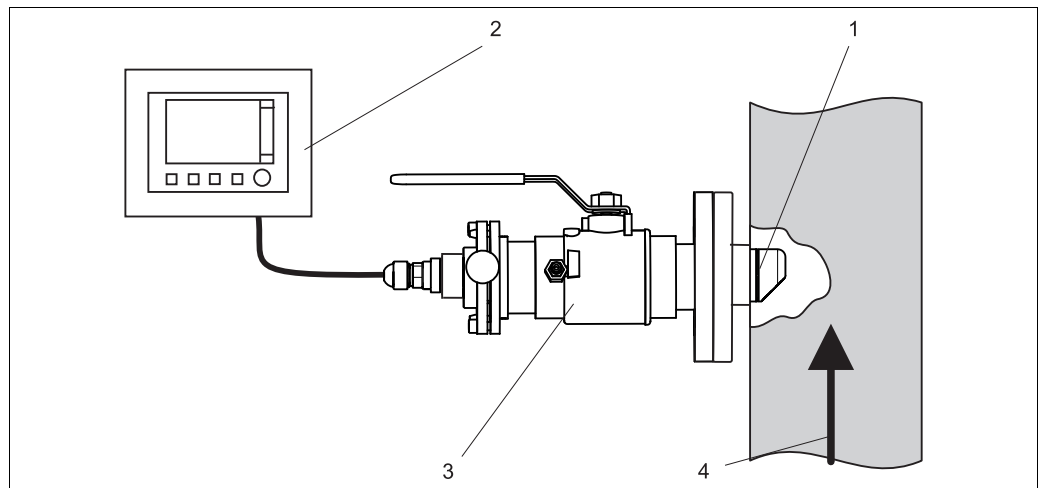

a0022229

Fig. 7: Measuring system with retractable assembly

- 1 Turbimax CUS52D turbidity sensor
- 2 Liquiline CM44x multichannel transmitter
- 3 Cleanfit CUA451 retractable assembly
- 4 Flow direction

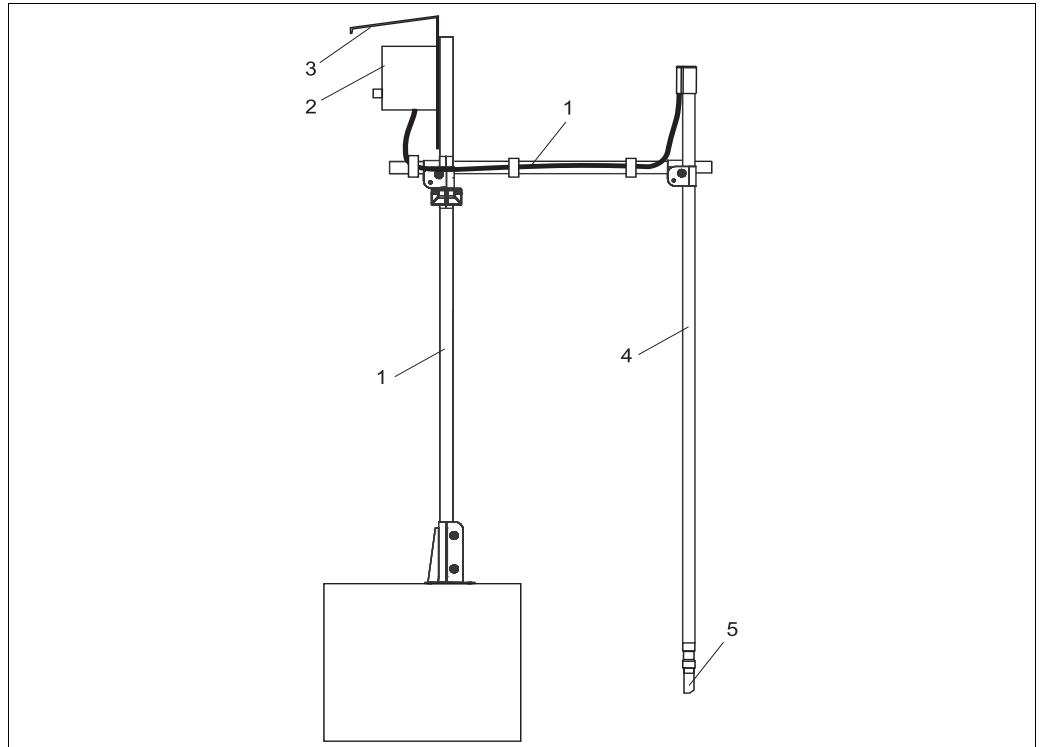

a0022020

Fig. 8: Measuring system with immersion assembly

- | | | | |
|---|--|---|----------------------------------|
| 1 | Liquiline CM44x multichannel transmitter | 4 | Flexdip CYA112 assembly |
| 2 | Weather protection cover | 5 | Turbimax CUS52D turbidity sensor |
| 3 | Flexdip CYH112 holder system | | |

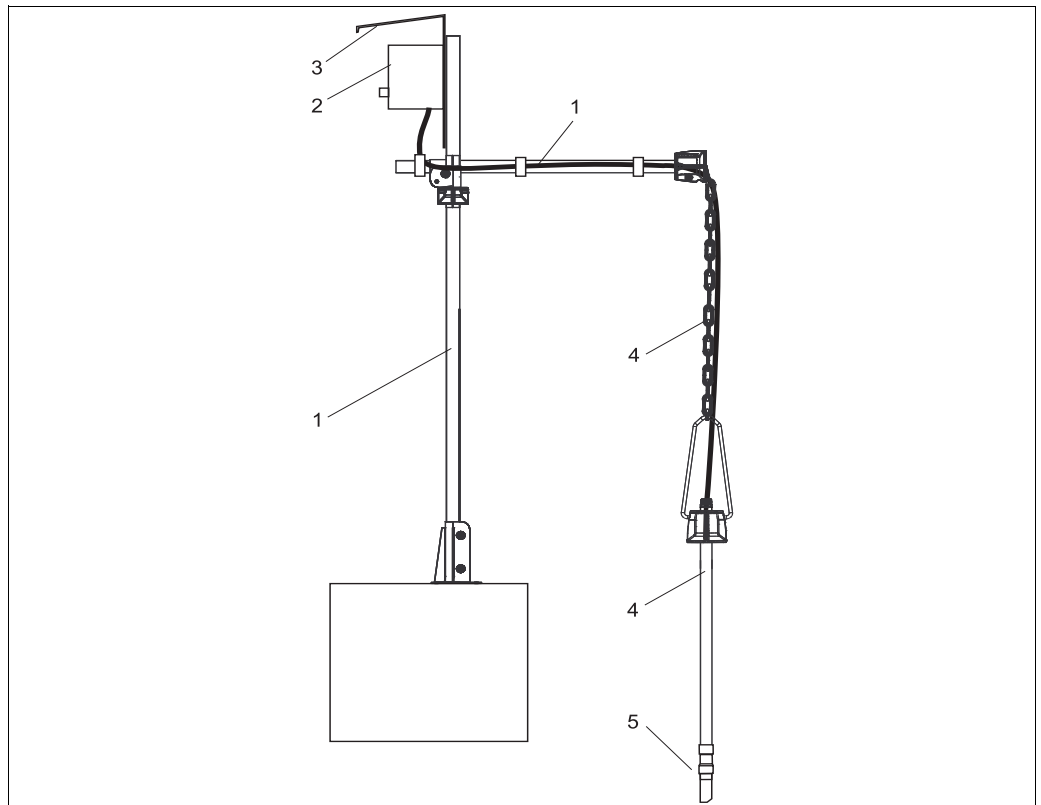

a0022023

Fig. 9: Measuring system with immersion assembly on chain holder system

- | | | | |
|---|--|---|----------------------------------|
| 1 | Flexdip CYH112 holder system | 4 | Flexdip CYA112 assembly |
| 2 | Liquiline CM44x multichannel transmitter | 5 | Turbimax CUS52D turbidity sensor |
| 3 | Weather protection cover | | |

3.3 Installation examples

3.3.1 Installation options

- with clamp connection
- with Flowfit CUA252 flow assembly
- with Flowfit CUA262 flow assembly
- with Cleanfit CUA451 retractable assembly
- with "E" or "S" flow assembly from CUS31
- with Flexdip CYA112 immersion assembly and Flexdip CYH112 holder system

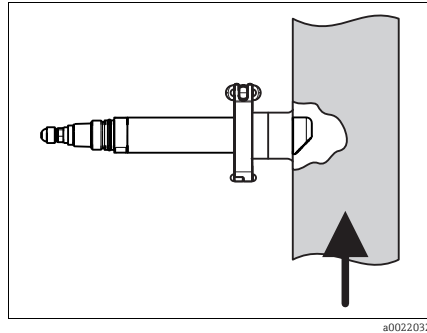

The installation angle is 90°. The arrow points in the direction of flow. The optical windows in the sensor must be aligned against the direction of flow. A weld-in adapter is available as an accessory for installation (see "Accessories" section).

Fig. 10: Installation with 2" clamp connection

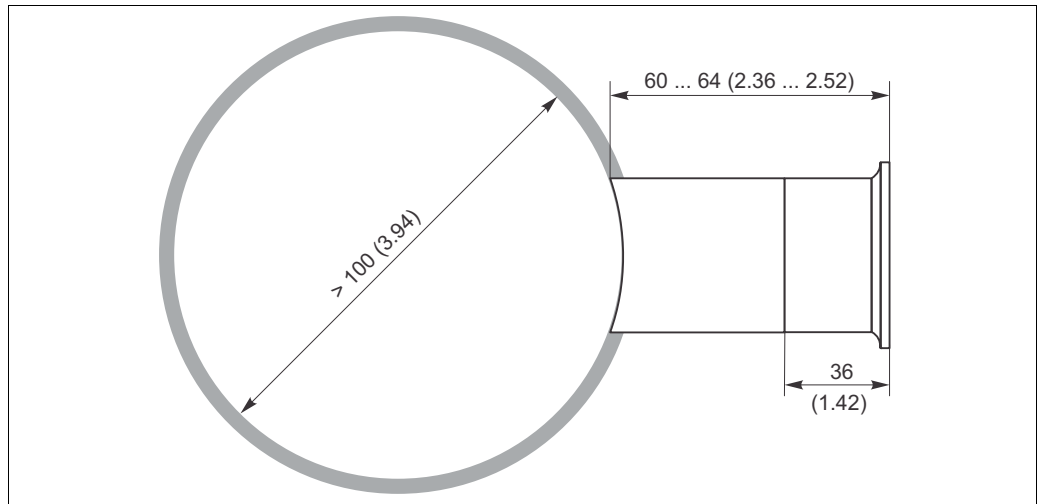
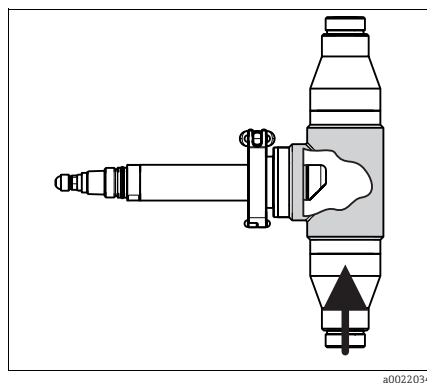

Fig. 11: Pipe connection with weld-in adapter, dimensions in mm (inch)



The installation angle is 90°. The arrow points in the direction of flow. The optical windows in the sensor must be aligned against the direction of flow.

Fig. 12: Installation with flow assembly CUA252

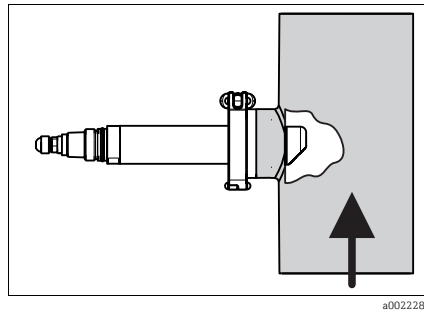

Fig. 13: Installation with flow assembly CUA262

The installation angle is 90°. The arrow points in the direction of flow. The optical windows in the sensor must be aligned against the direction of flow.

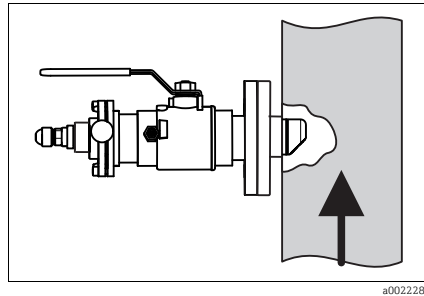

Fig. 14: Installation with retractable assembly CUA451

The installation angle is 90°. The arrow points in the direction of flow. The optical windows in the sensor must be aligned against the direction of flow. For manual insertion/retraction of the assembly the medium pressure may not exceed 2 bar (29 psi).

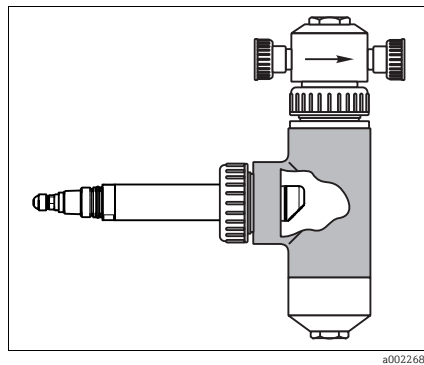

Fig. 15: Installation in CUS31-S flow assembly

The installation angle is 90°. The alignment of the sensor depends on the medium. In the case of media with little outgassing and with a tendency to form deposits, the optical windows face downwards (as shown in the graphic). In the case of media with strong outgassing and with no tendency to form deposits, the optical windows face upwards. The installation marking on the sensor helps the user align the sensor.

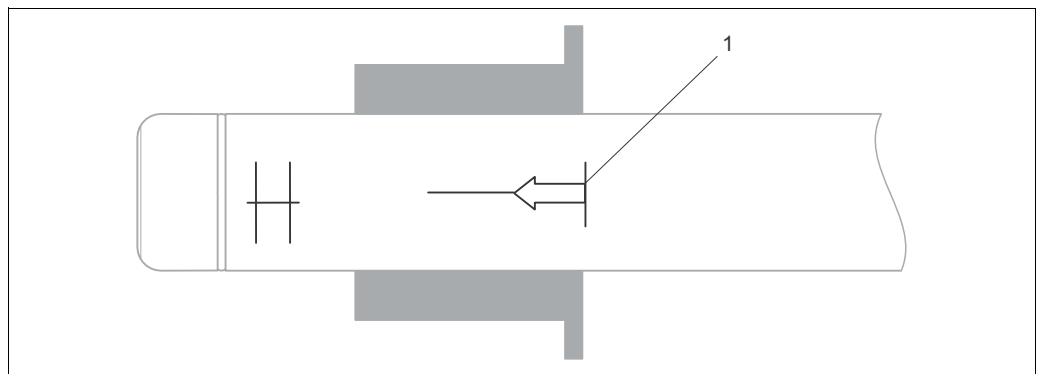

Fig. 16: Installation marking for sensor alignment in the CUS31-S flow assembly

1 Installation marking

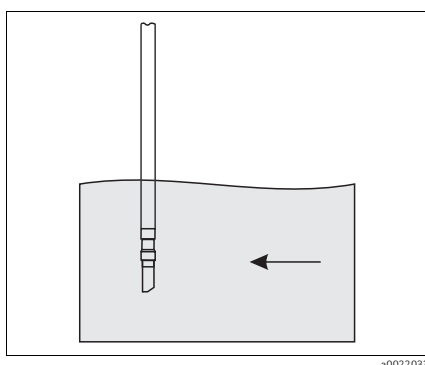

Fig. 17: Installation with immersion assembly

The arrow points in the direction of flow.

The installation angle is 0° .

If you are using the sensor in open basins, the sensor must be installed in such a way that bubbles cannot accumulate on it.

3.3.2 Pipe installation

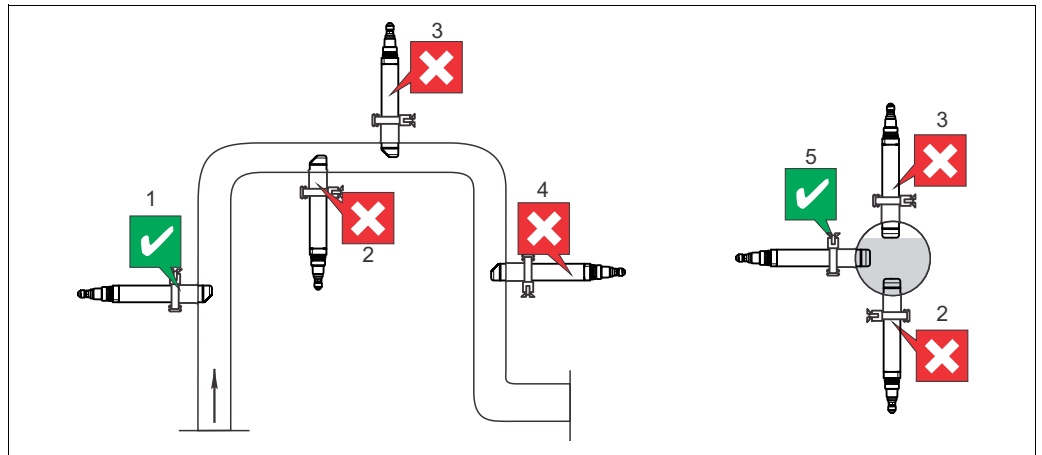

Fig. 18: Orientation and positions

- Install the sensor in places with uniform flow conditions.
- The best installation location is in the ascending pipe (pos. 1). Installation is also possible in the horizontal pipe (pos. 5).
- Do not install in places where air spaces or bubbles occur (pos. 3) or where sedimentation may occur (pos. 2).
- Avoid installation in the down pipe (pos. 4).
- Avoid fittings downstream from pressure reduction stages which may cause outgassing.

Wall effects:

Backscattering on the pipe wall may result in the distortion of measurement values in the case of turbidity values < 200 FNU. Assembly adjustment is recommended. Black plastic pipes with diameter > DN 60 exhibit hardly any wall effects (<0.05 FNU). For this reason, the use of black plastic pipes is recommended.

Additional information on avoiding wall effects:

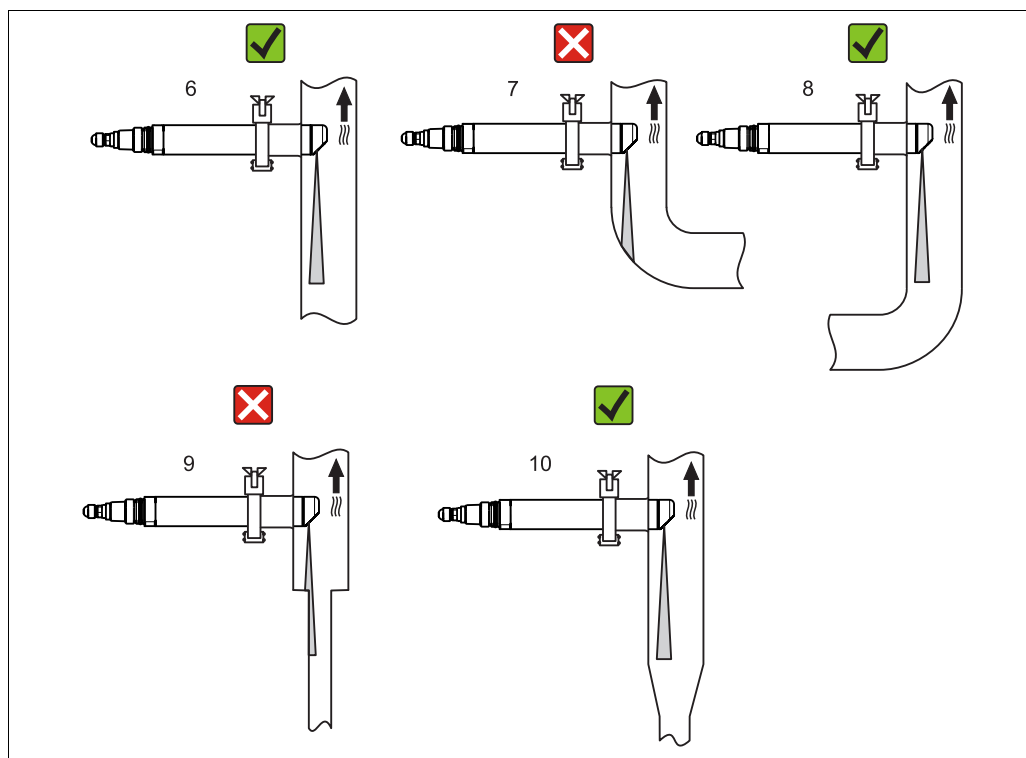

Fig. 19: Orientations for pipes and assemblies

- Install the sensor in such a way that the light beam is not reflected (pos. 6).
- Avoid sudden changes in cross-section (pos. 9). Changes in cross-section should be gradual and located as far away as possible from the sensor (pos. 10).
- Do not install the sensor directly downstream from a bend (pos. 7). Instead position it as far away as possible from the bend (pos. 8).
- When using reflective materials (e.g. stainless steel), the pipe diameter must be at least 100 mm (4"). An assembly adjustment onsite is recommended.
- Pipes made of stainless steel with diameter >DN 300 exhibit hardly any wall effects.

3.3.3 Immersion operation

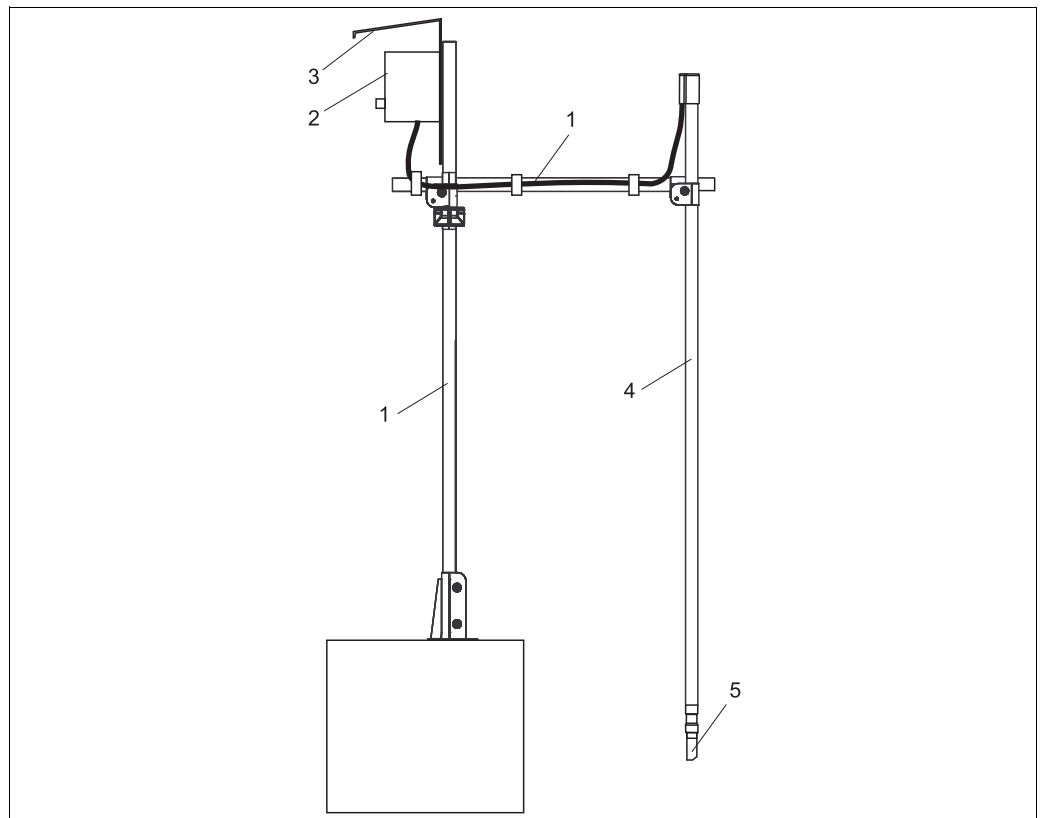

Fig. 20: Measuring system with immersion assembly

- | | | | |
|---|--|---|----------------------------------|
| 1 | Flexdip CYH112 holder system | 4 | Flexdip CYA112 assembly |
| 2 | Liquiline CM44x multichannel transmitter | 5 | Turbimax CUS52D turbidity sensor |
| 3 | Weather protection cover | | Weather protection cover |

This type of installation is particularly suitable for strong or turbulent flow (>0.5 m/s (1.6 ft/s)) in basins or channels.

Compressed air cleaning

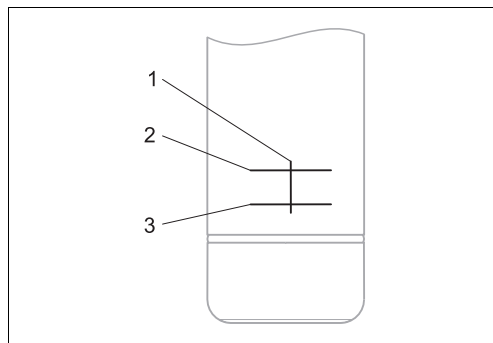

Fig. 21: Installation marks 1 to 3

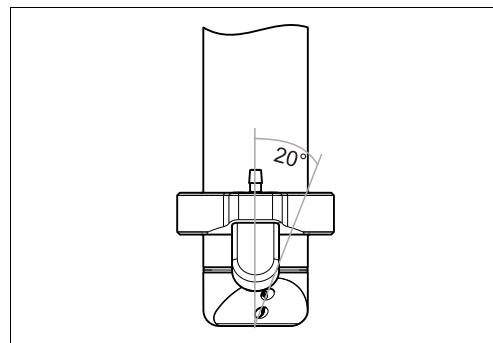





Fig. 22: Mounting position

Mount the compressed air cleaning system as follows:

1. Fit the compressed air cleaning system on the sensor (→  22).
2. Position the securing ring of the compressed air cleaning system between installation marks 2 and 3 (→  21)
3. Using a 4 mm Allen key, tighten the securing screw of the compressed air cleaning system slightly so that the compressed air cleaning system can still be rotated.
4. Turn the compressed air cleaning system so that the slit on the black ring is on installation mark 1 (→  21). This way the nozzle is offset by 20° when blowing air at the optical windows.
5. Tighten the securing screw.
6. Fit the compressed air hose on the hose connection.

3.4 Post-installation check

- ▶ Sensor and cable undamaged?
- ▶ Is the orientation correct?
- ▶ Is the sensor installed in an assembly and not suspended freely from a cable?

4 Electrical connection

▲ WARNING

The device is live!

Incorrect connection may result in injury or death

- ▶ The electrical connection must only be established by an electrical technician.
- ▶ The electrical technician must have read and understood these Operating Instructions and must follow the instructions they contain.
- ▶ **Prior to commencing** the connection work, make sure no voltage is applied at any of the cables.

4.1 Connecting to the transmitter

The sensor is connected to the Liquiline CM442 transmitter as follows:

- With the M12 plug (version: fixed cable, M12 plug)
- With the fixed cable connected to the terminal strips (version: fixed cable, end sleeves):

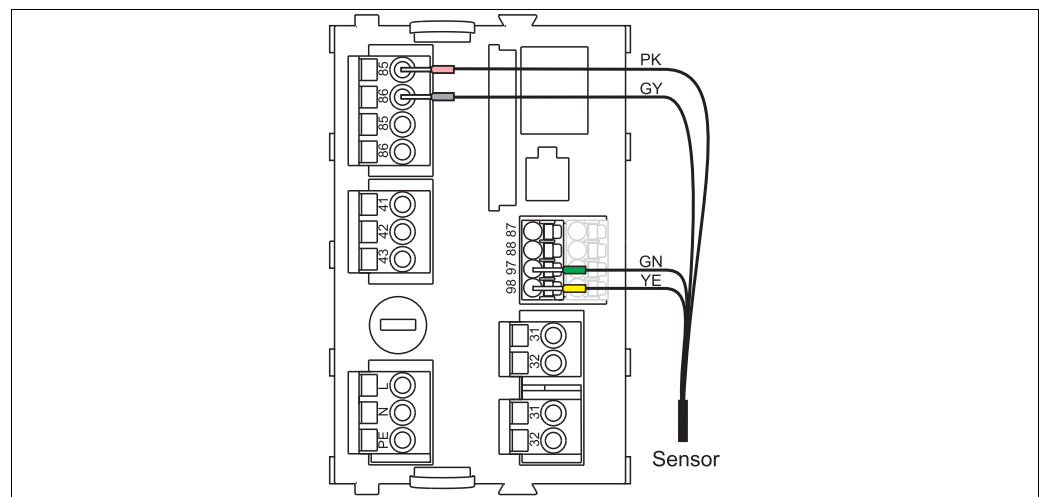

Fig. 23: Sensor connection

The maximum cable length is 100 m (328 ft).

4.2 Post-connection check

Device condition and specifications	Notes
Is damage visible on the outside of the sensor, assembly, junction box or cable?	Visual inspection
Electrical connection	Notes
Does the transmitter supply voltage match the specifications on the nameplate?	
Are the installed cables strain-relieved and not twisted?	
Is the cable type route completely isolated at the mounting location?	Power cables / signal cables
Are the power supply and signal cables connected correctly?	Use the transmitter wiring diagram
Are the cable cores stripped sufficiently and installed correctly in the terminal?	Check if seated correctly (pull gently)
Are all the screw terminals firmly tightened?	Tighten
Are all the cable entries installed, firmly tightened and leak-tight?	For lateral cable entries, make sure the cable loops downwards to ensure water can drain off.
Are all the cable entries mounted on the side or pointing downwards?	

5 Device description

5.1 Sensor design

The sensor is suitable for all drinking water and process water applications.

The sensor is designed as a 40 mm sensor that can be operated directly and completely in the process without the need for further sampling (in situ).

All the necessary modules are contained in the sensor:

- Power supply
- Light sources
- Detectors detect the measuring signals, digitize them and process them to form a measured value.
- The sensor microcontroller is responsible for controlling the internal processes and transmitting the data.

All the data - including the calibration data - are stored in the sensor. The sensor can thus be precalibrated and used at a measuring point, calibrated externally, or used for several measuring points with different calibrations.

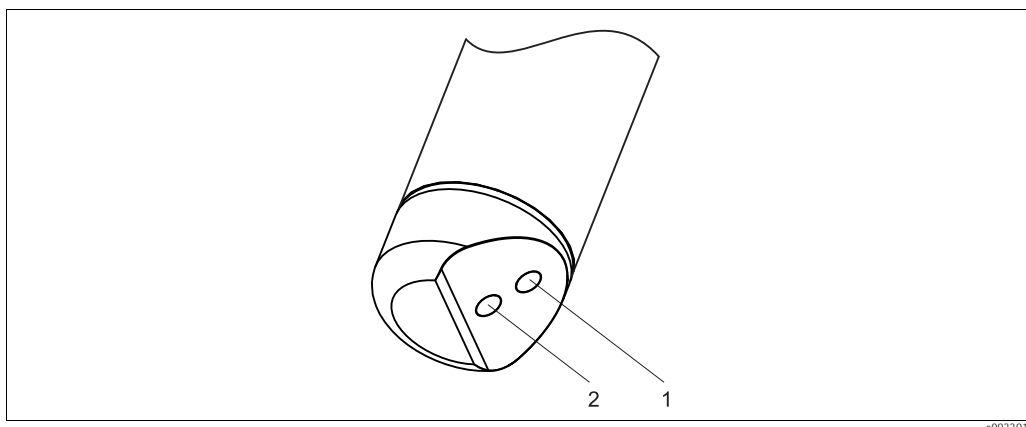

Fig. 24: Arrangement of light source and light receiver

- 1 Light receiver
- 2 Light source

5.2 Measuring principle

The sensor works using the 90° light scattering principle in accordance with ISO 7027 and meets all the requirements of this standard (no divergence and a maximum divergence of 1.5°). The ISO 7027 standard is obligatory for turbidity measurements in the drinking water sector.

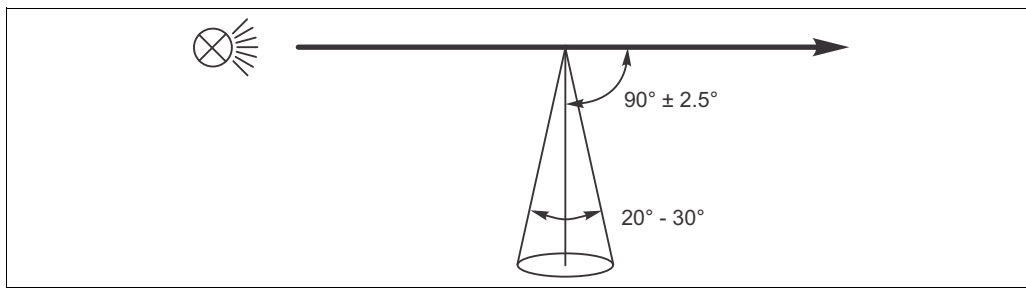

Fig. 25: Measurement in accordance with ISO 7027

Measurement is done using a wavelength of 860 nm.

5.3 Applications

The formazin factory calibration is used as the basis for precalibrating additional applications and optimizing them for the different media characteristics.

Application: water	Recommended operational range	Max. display range
Factory calibration for formazin	0.000 to 4000 FNU	0.000 to 9999 FNU
Application: Kaolin	0 to 600 mg/l	0 to 3 g/l
Application: PSL	0 to 500 度	0 to 3000 度
Application: diatomite	0 to 2200 mg/l	0 to 10 g/l

To adapt to a specific application, customer calibrations can be carried out with up to 6 points.

5.4 Calibration

The sensor is precalibrated on leaving the factory. As such, it can be used in a wide range of applications without the need for additional calibration.

In addition the sensor offers a variety of ways to adapt the measurement to the particular application:

- Assembly adjustment (compensation of wall effects in pipes and assemblies)
- Calibration or adjustment (1 to 6 points)
- Enter a factor (multiply the measured values by a constant factor)
- Enter an offset (add/subtract a constant value to/from the measured values)
- Duplicate the factory calibration data records

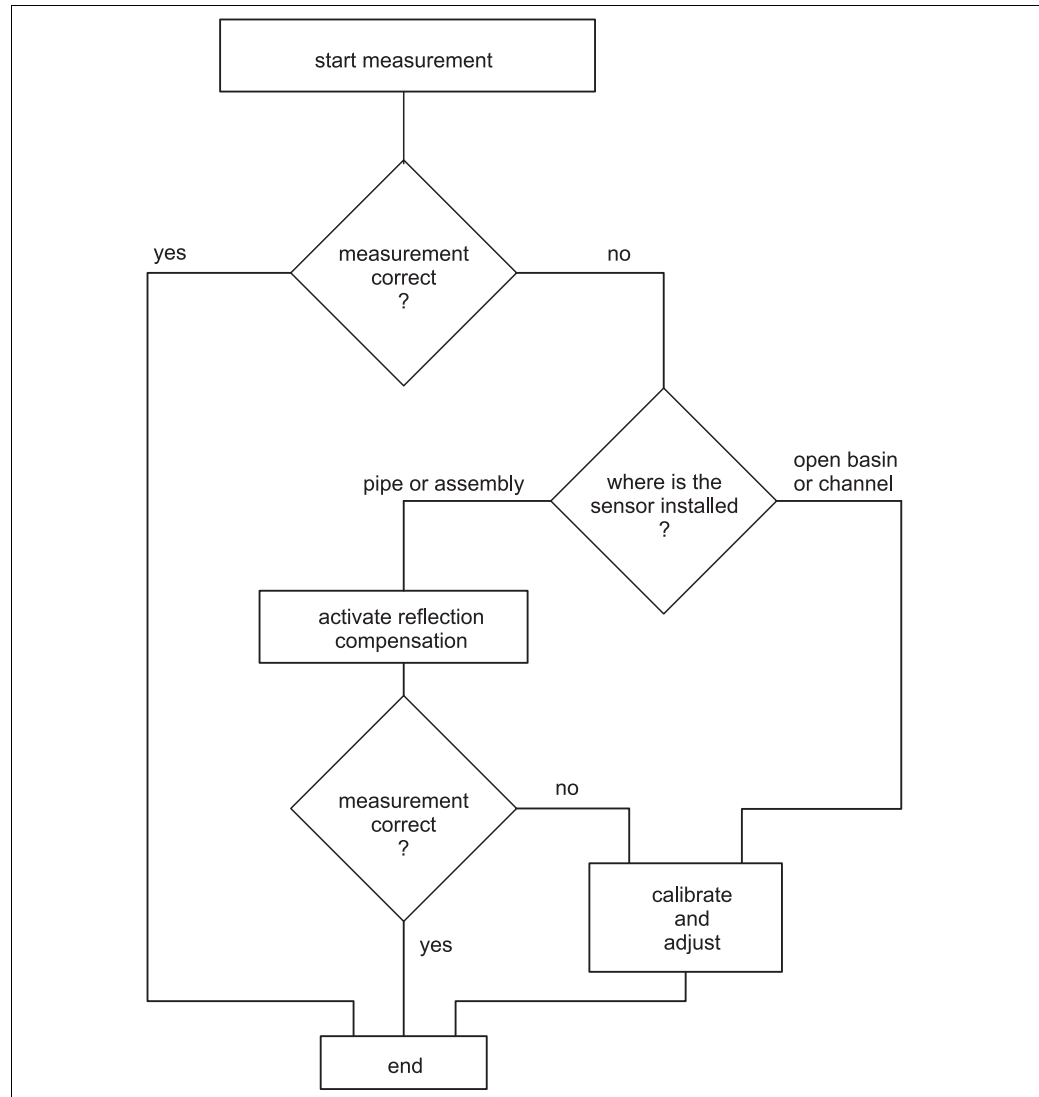

Fig. 26: Flowchart

i To use the "Offset", "Factor" or "Assembly adjustment" functions, a new data record must first be created using 1 to 6-point calibration or by duplicating a factory data record.

5.4.1 Assembly adjustment

Both the optical design of the CUS52D sensor and the CUA252 and CUA262 flow assemblies are optimized to minimize measured errors caused by wall effects in assemblies or pipes (measured error in CUA252 < 0.02 FNU).

Using the "Assembly adjustment" function, it is possible to automatically compensate for the remaining measured errors caused by wall effects. The programmed function is based on formazin measurements and therefore may require subsequent calibration to adjust the measurement to the corresponding application or medium.

The following types of assembly adjustment are available:

Adjustment	Description
PE 100	Adjustment to Flowfit CUA 252 flow assembly
1.4404 (AISI 316 L)	Adjustment to CUA 262 flow assembly
Standard customer adjustment	Adjustment to any pipes / assemblies
Specialist customer adjustment	Adjustment only recommended for E+H Service staff

- If the "PE100" and "1.4404/316L" assembly adjustment options are selected, no other parameters must be specified.
- The "Standard customer adjustment" option requires the user to enter additional parameters (material, surface and internal diameter).

5.4.2 Calibration / adjustment

The factory calibrations of the individual applications (Formazin, Kaolin, PSL, Diatomite) are each based on 20 calibration points.

Apart from the uneditable factory calibrations, the sensor contains six additional data records for saving process calibrations or for adaptation to the corresponding measuring point (application).

5.4.3 Selecting the applications

On the CM44x, select the appropriate application for your field of application during initial commissioning or calibration.

Model name	Application	Unit
Formazin	Drinking water, process water	FNU; NTU; TE/F; EBC; ASBG
Kaolin	Drinking water, filtratable substances, process water	mg/l; g/l; ppm
PSL	The calibration standard commonly used in Japan for drinking water turbidity	度 (dough)
Diatomite	Mineral-based solids (sand)	mg/l; g/l; ppm

1 to 6 points can be calibrated for all applications.

5.4.4 Single-point and multipoint calibration

- Before a calibration, rinse the system until all air pockets and fouling are removed.
- You can edit both the actual values and the target values in the calibration table (right and left column)
- You can also add additional pairs of calibration values without measuring in a medium.
- Lines interpolate between the calibration points.
- When factory calibration data records are duplicated, the value pair 1000/1000 is automatically generated to map the factory data record 1:1 to the duplicated record. If you perform a single-point or multipoint calibration after duplicating the data record, you must delete this value pair (1000/1000) from the calibration table.

Single-point calibration

Application example:

The sensor measured value in an application deviates from the laboratory value. This is corrected by a single-point calibration.

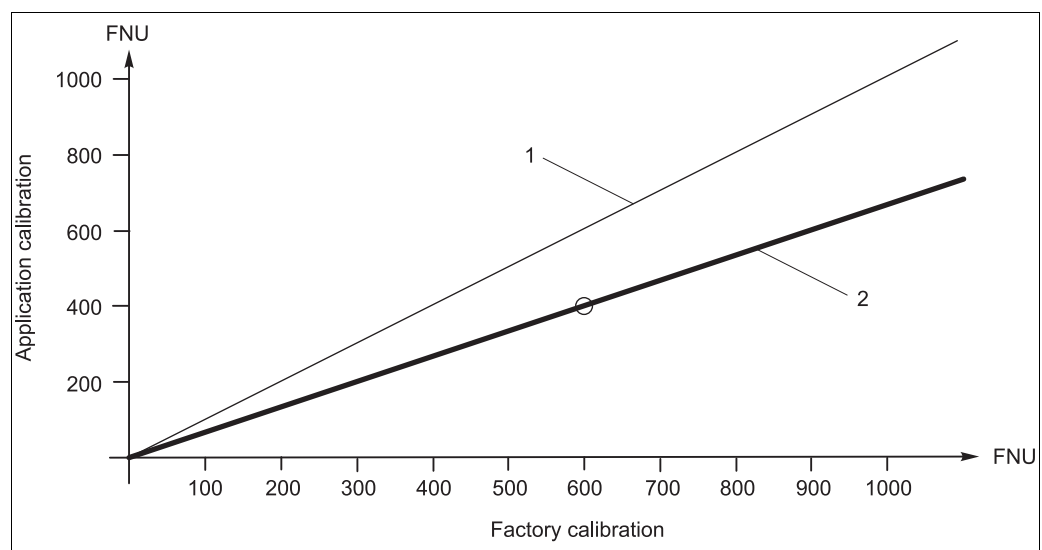

Fig. 27: Example for single-point calibration

- 1 Factory calibration
2 Application calibration

Proceed as follows:

1. Select a data record.
2. Set a calibration point in the medium or enter the target sample value (laboratory value).

In our example (→ Fig. 27) these are the values 600 FNU (measured value) and 400 FNU (target sample value). The gain for the application calibration changes accordingly.

Measured value	Target sample value
600	400

Two-point calibration

Application example:

Deviations in the measured value must be compensated for at two different points in an application (e.g. maximum value and minimum value of the application). This aims to ensure a maximum level of accuracy between these two extremes.

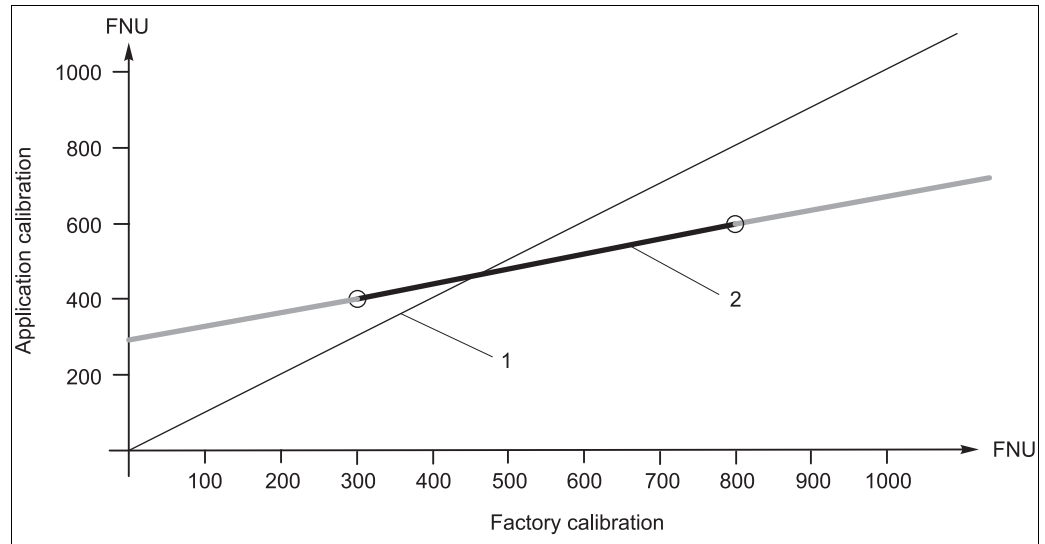

Fig. 28: Example for two-point calibration

- 1 Factory calibration
- 2 Application calibration

Proceed as follows:

1. Select a data record.
2. Set two different calibration points in the medium or enter the target sample values for your application range.

In our example (→ Fig. 28) these are the values 300 FNU (measured value) and 400 FNU (target sample value) as well as 800 FNU / 600 FNU. The gain and offset for the application calibration change accordingly.

Measured value	Target sample value
300	400
800	600

i The gain outside the selected operational range is determined by the adjacent operational range (gray line). The characteristic must increase monotonically.

Three-point calibration

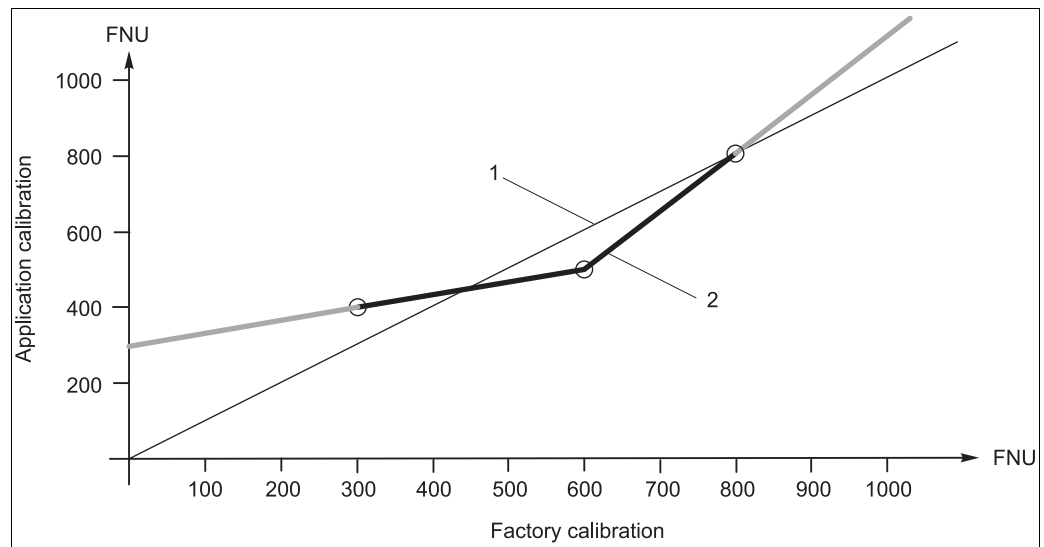

Fig. 29: Example for three-point calibration

- 1 Factory calibration
2 Application calibration

Proceed as follows:

1. Select a data record.
2. Set three different calibration points in the medium or enter the measured values and target sample values for your application range.
In our example (→ Fig. 29) these are 300 / 400, 600 / 500 and 800 / 800. The gain and offset for the application calibration change accordingly.

Measured value	Target sample value
300	400
600	500
800	800

- i** The gain outside the selected operational range is determined by the adjacent operational range (gray line).
The characteristic must increase monotonically.

Four-point calibration

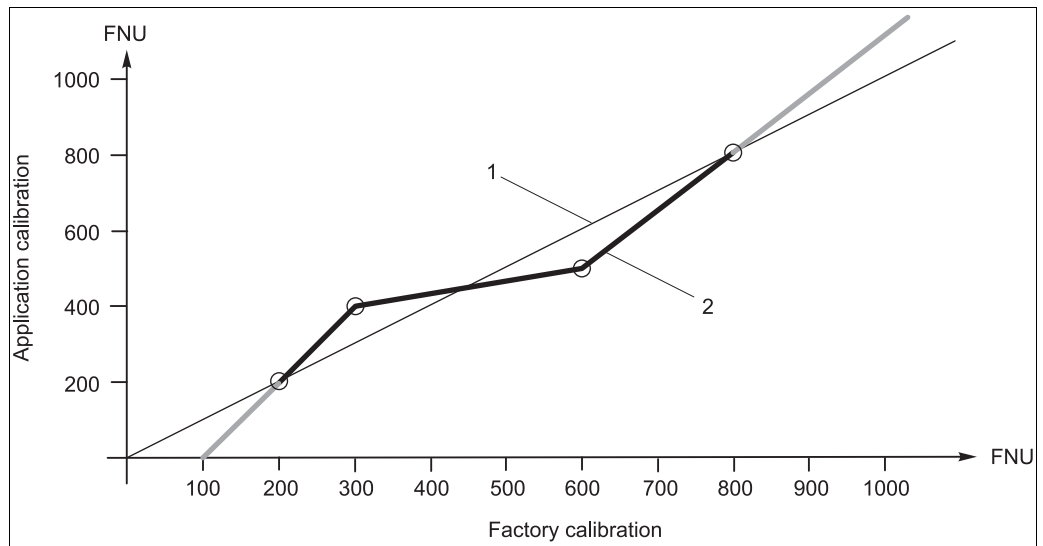



Fig. 30: Example for four-point calibration

- 1 Factory calibration
- 2 Application calibration

Proceed as follows:

1. Select a data record.
2. Set four different calibration points in the medium or enter the measured values and target sample values for your application range.
 In our example (→  30) these are 200 / 200, 300 / 400, 600 / 500 and 800 / 800.
 The gain and offset for the application calibration change accordingly.

Measured value	Target sample value
200	200
300	400
600	500
800	800

 The gain outside the selected operational range is determined by the adjacent operational range (gray line).
 The characteristic must increase monotonically.

Calibration example for filter monitoring

Application example:

If a threshold is exceeded, the measured value is set to a maximum value regardless of the actual turbidity.

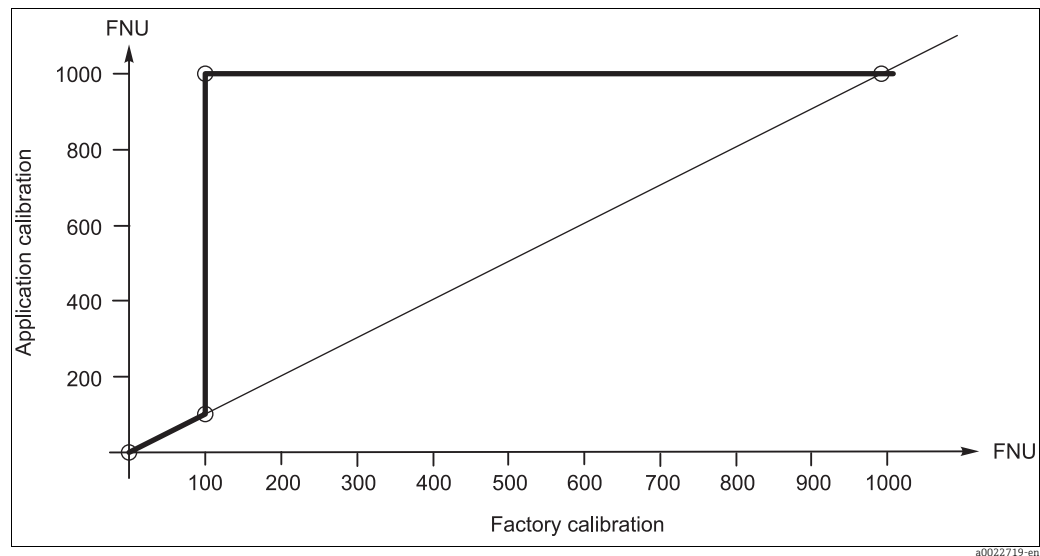



Fig. 31: Example for filter monitoring

Values for example above (→  31):

Measured value	Target sample value
0	0
100	100
101	1000
1000	1001

5.4.5 Factor

With the "Factor" function, the measured values are multiplied by a constant factor. The functionality corresponds to that of a single-point calibration.

Example

This type of adjustment can be selected if the measured values were compared to the laboratory values over an extended period and all the values are too low by a constant factor of 10%, for instance.

The values are adjusted by entering the factor 1.1.

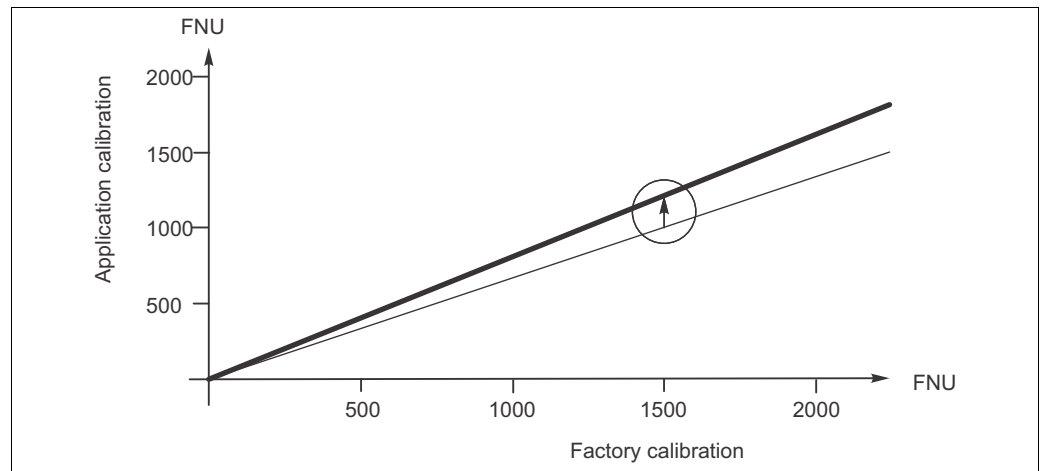

Fig. 32: Example for factor

i To use the "Factor" function, a new data record must first be created using 1 to 6-point calibration or by duplicating a factory data record.

5.4.6 Offset

With the "Offset" function, the measured values are offset by a constant amount (added or subtracted).

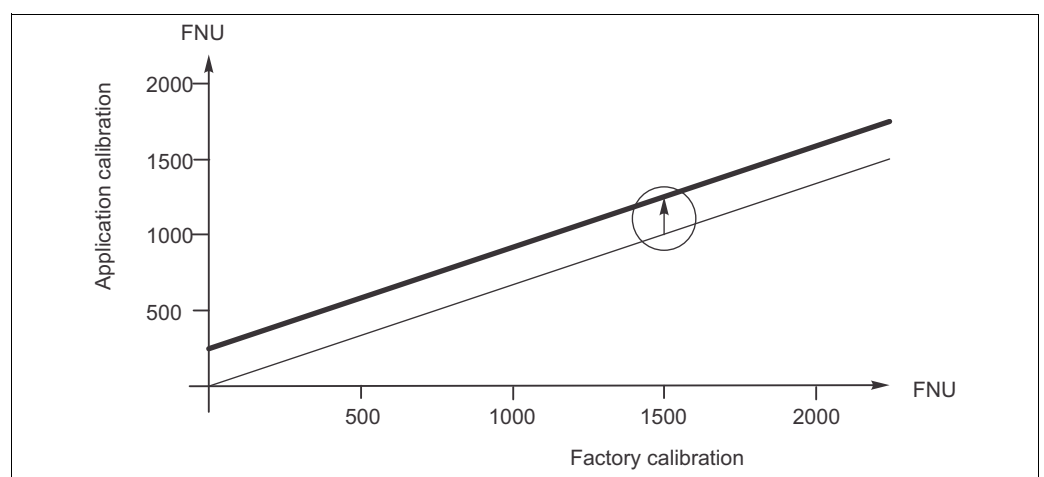

Fig. 33: Example for offset

i To use the "Offset" function, a new data record must first be created using 1 to 6-point calibration or by duplicating a factory data record.

5.5 Cyclic cleaning

Compressed air is most suitable for cyclic cleaning in open basins and channels. The optional cleaning unit is either ready-supplied or can be retrofitted, and is fitted on the sensor head. It operates at a rate of 50 l/min (13.2 US gal/min)

The following settings are recommended for the cleaning unit:

Type of fouling	Cleaning interval	Cleaning duration
Severe fouling with rapid buildup	5 min	10 s
Low degree of fouling	10 min	10 s

The CYR52 ultrasonic cleaning system is suitable for cyclic cleaning in pipes and assemblies. The (retrofittable) cleaning unit can be mounted on the CUA252, CUA262 flow assemblies, the flow assembly of CUS31 or on any customer pipe.

The following cleaning settings are recommended to prevent the ultrasonic transducer from overheating:

Cleaning duration	max. 5 seconds
Cleaning interval	min. 5 minutes

5.6 Signal filter

Optical turbidity measurements have a low signal-to-noise ratio particularly in the low turbidity range. In addition, disturbance variables can occur as a result of air bubbles, fouling etc. However a high level of damping affects the sensitivity of the measured value required in applications.

For this reason, the sensor is fitted with an internal signal filter function in order to adapt the measurement flexibly to different measuring requirements. The following filter settings are possible:

Measured value filter	Description
Weak	Low filtering, high sensitivity, fast response time (2 sec.) to changes
Normal (default)	Medium filtering, 10 sec. response time
Strong	Strong filtering, low sensitivity, slow response to changes (25 sec.)
Specialist	This menu is designed for the Endress+Hauser Service Team.

5.7 Calkit CUS52 solid state reference

The function and accuracy of the CUS52D sensor can be checked with the Calkit CUS52 solid state references. During factory calibration, every solid state reference is aligned with a special CUS52D sensor and can only be used with this sensor. Therefore the solid state reference and the CUS52D sensor are married (permanently assigned) to one another.

The following solid state references are available:

- 5 FNU (NTU)
- 20 FNU (NTU)
- 50 FNU (NTU)

The reference value indicated on the solid state reference is reproduced with an accuracy of $\pm 10\%$ when the sensor is operating correctly.

Function check using Calkit CUS52

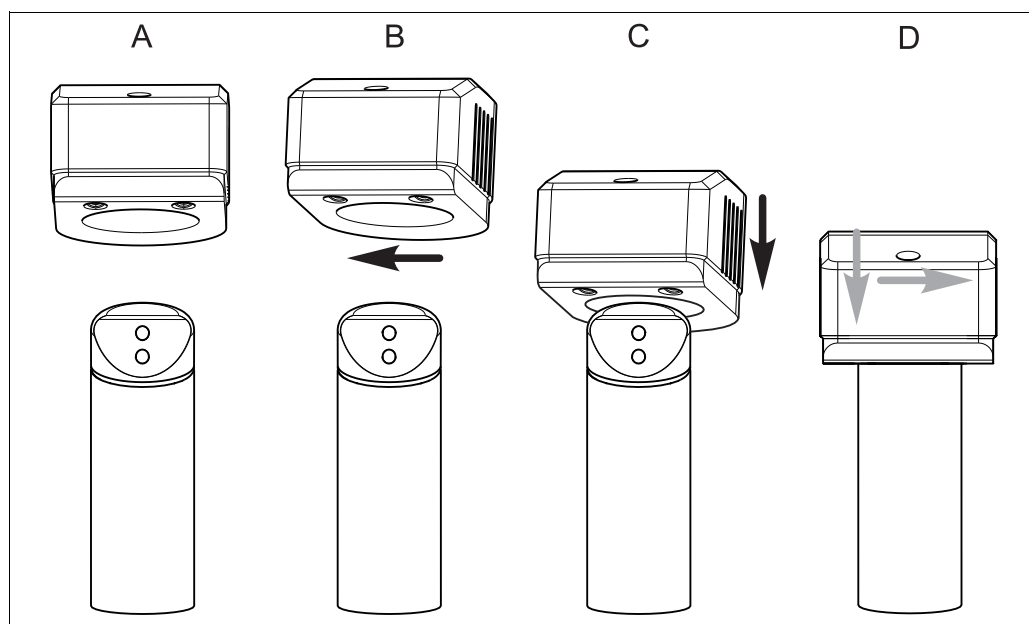

Fig. 34: Fitting the solid state reference on the sensor

Preparatory steps:

1. Clean the sensor (see the "Cleaning the sensor" section).
2. Fix the sensor in place (e.g. with a laboratory stand).
3. With the solid state reference turned slightly (\rightarrow Fig. 34, B), fit it gently on the sensor (C) and
4. then allow the solid state reference to slide into the final position (D).

Function check:

1. Enable the factory calibration on the transmitter.
2. Read off the measured value at the transmitter (depending on the signal filter settings it can take 2 to 25 seconds until the correct measured value appears).
3. Compare the measured value with the reference value on the Calkit52. The sensor is working perfectly if the value deviates by less than 10%.

i If you activate a calibration data record other measured values will result. Therefore, always select the factory calibration (formazin) when checking the function with Calkit solid state references.

6 Diagnostics and troubleshooting

You must take the entire measuring point into account when troubleshooting:

- Transmitter
- Electrical connections and cables
- Assembly
- Sensor

The possible causes of error indicated in the table below primarily refer to the sensor.

Problem	Check	Remedial measures
Nothing displayed, no reaction from the sensor	Power supplied to the transmitter? Sensor connected correctly? Buildup on optical windows?	Connect the mains voltage Connect sensor correctly Clean sensor
Display value too high or too low	Buildup on optical windows? Sensor calibrated?	Clean Calibrate
Display value fluctuates a lot	Check mounting location.	Select other mounting location Adjust the measured value filter

-  Please observe the troubleshooting instructions provided in the transmitter operating manual. Examine the transmitter if necessary.

7 Maintenance

You have to perform maintenance tasks at regular intervals.

We recommend setting the maintenance times in advance in an operations journal or log.

The maintenance cycle primarily depends on the following:

- The facility
- The installation conditions
- The medium being measured

⚠ CAUTION

Risk of injury due to acid or medium

- ▶ Switch off the cleaning unit before removing the sensor from the medium.

7.1 Cleaning the sensor

Sensor fouling can affect the measurement results and even cause a malfunction.

The sensor must be cleaned at regular intervals to ensure reliable measurement results. The frequency and intensity of the cleaning process depends on the medium.

Clean the sensor:

- As specified in the maintenance schedule
- Before every calibration
- Before returning the sensor for repair

Type of fouling	Cleaning measure
Lime deposits	Immerse the sensor in 1-5 % hydrochloric acid (for a few minutes).
Dirt particles on the optical windows	Use a cleaning cloth to clean the optical windows.

- i** You must rinse the sensor thoroughly with water after cleaning.

8 Repair

8.1 Spare parts kits

Order number	Description
71247510	Cable assembly, ferrules, 3 m cable length
71247510	Cable assembly, ferrules, 7 m cable length
71247510	Cable assembly, ferrules, 15 m cable length
71247510	Cable assembly, M12 plug, 3 m cable length
71247510	Cable assembly, M12 plug, 7 m cable length
71247510	Cable assembly, M12 plug, 15 m cable length

Detailed information on the spare parts kits is available in the "Spare Part Finding Tool", which can be accessed on the Web at:

www.products.endress.com/spareparts_consumables

8.2 Return

The product must be returned if repairs or a factory calibration are required, or if the wrong product has been ordered or delivered. According to legal regulations Endress+Hauser, as an ISO-certified company, is required to follow certain procedures when handling returned products that are in contact with the medium.

To ensure swift, safe and professional device returns:

Visit our website to obtain information about the return procedure and basic conditions:

www.services.endress.com/return-material

8.3 Disposal

The device contains electronic components and must therefore be disposed of in accordance with regulations on the disposal of electronic waste.

Please observe local regulations.

9 Accessories

9.1 Assemblies

Flowfit CUA252 flow assembly

- For CUS52D
- Order as per product structure (--> Online Configurator, www.products.endress.com/cua252)
- Technical Information TI01139C/07/EN

Flowfit CUA262 flow assembly

- For CUS52D
- Order as per product structure (--> Online Configurator, www.products.endress.com/cua262)
- Technical Information TI01152C/07/EN

Flexdip CYA112 wastewater assembly

- Modular assembly system for sensors in open basins, channels and tanks
- PVC and stainless steel version
- Order as per product structure (--> Online Configurator, www.products.endress.com/cya112)
- Technical Information TI00432C/07/EN

Cleanfit CUA451 retractable assembly

- Manual retractable assembly made of stainless steel with ball valve shut-off for turbidity sensors
- Order as per product structure (--> Online Configurator, www.products.endress.com/cua451)
- Technical Information TI00369C/07/EN

9.2 Mounting material

Weld-in adapter for clamp connection DN 50

- Material: 1.4404 (AISI 316 L)
- Wall thickness 1.5 mm
- Order number: 71242201

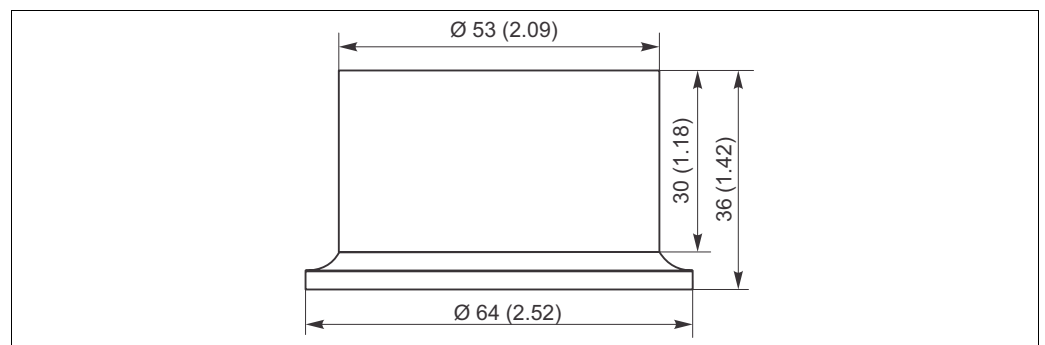

Fig. 35: Dimensions in mm (inch)

a0022838

9.3 Holder

Flexdip CYH112 holder system for Flexdip CYA112 water and wastewater assemblies

- Modular holder system for sensors and assemblies in open basins, channels and tanks
- The holder system can be secured in any way, be it on the floor, the cap stone, the wall or directly on a railing.
- Stainless steel version
- Order as per product structure (--> Online Configurator: www.products.endress.com/cyh112)
- Technical Information TI00430C/07/EN

9.4 Compressed air cleaning

Compressed air cleaning for CUS52D

- Connection: 6 mm
- Materials: PE black
- Order no.: 71242026

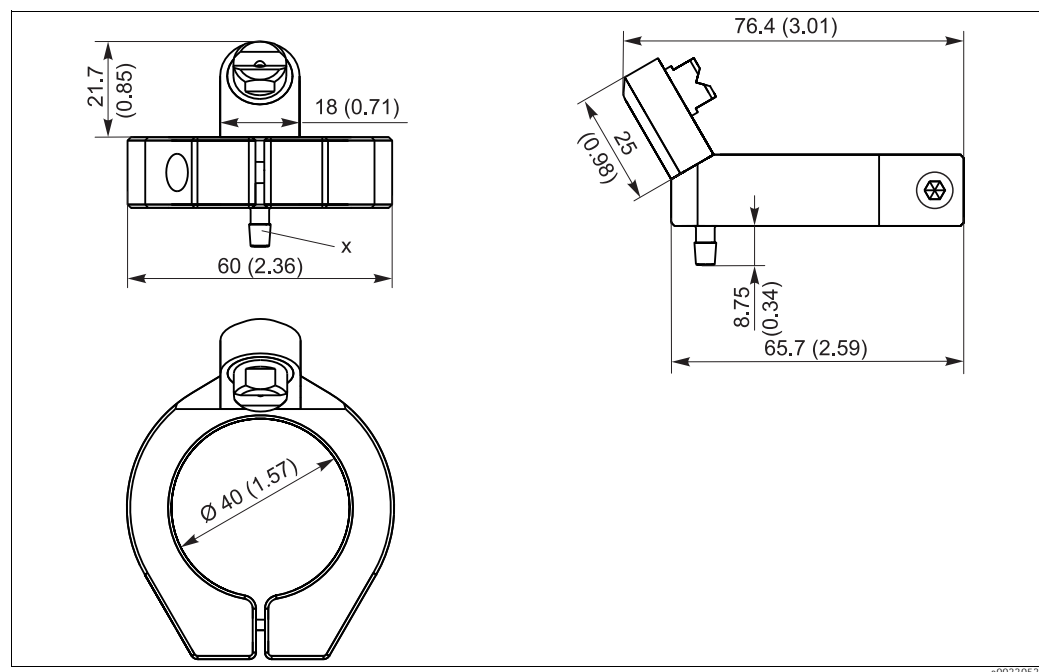

Fig. 36: Compressed air cleaning, dimensions in mm (inch)

X 6 mm hose nozzle

Compressor

- For compressed air cleaning
- 230 V AC order no. 71072583
- 115 V AC order no. 71194623

9.5 Ultrasonic cleaning

Ultrasonic cleaning system CYR52

- For attachment to assemblies and pipes
- Order as per product structure (--> Online Configurator, www.products.endress.com/cyr52)
- Technical Information TI01153C/07/EN

9.6 Bubble trap

Bubble trap

- For sensor CUS52D
- Process pressure: up to 3 bar (43.5 psi)
- Process temperature: 0 to 50 °C (32 to 122 °F)
- Adapter to D 12 with connection for vent line (top connection on CUA252), is included in the delivery.
- Orifice plates for the following volume flow rates:
 - < 60 l/h (15.8 gal/hr)
 - 60 to 100 l/h (15.8 to 26.4 gal/hr)
 - > 100 l/h (26.4 gal/hr)
- The vent line is fitted with a PVC hose, hose check valve and a Luer lock adapter.
- Order number, suitable for assembly CUA252: 71242170
- Order number, suitable for assembly S of CUS31: 71247364

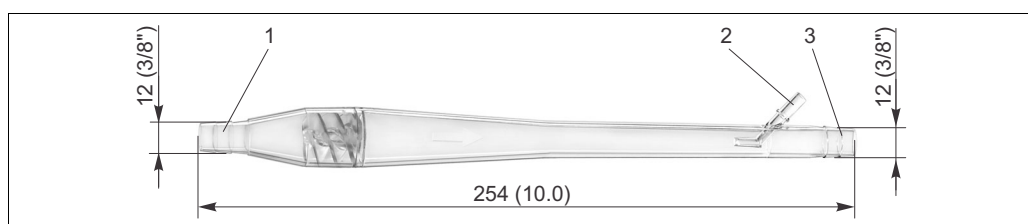

Fig. 37: Bubble trap, dimensions in mm (inch)

- 1 Inlet for medium (without hose system)
- 2 Outlet for bubbles (hose system is included in scope of supply)
- 3 Outlet for medium (without hose system)

9.7 Calibration set

CUY52 calibration set

- For CUS52D
- Order as per product structure (--> Online Configurator, www.products.endress.com/cuy52)
- Technical Information TI01154C/07/EN

9.8 Transmitter

Liquiline CM44x/CM44xR

- Multichannel transmitter for connecting digital sensors with Memosens technology
- Field device (CM44x) or DIN rail device (CM44xR)
- Power supply 100 to 230 V AC, 24 V AC/DC
- Universally extensible
- Slot for SD card
- Order as per product structure (--> Configurator on product page)
- Technical Information TI00444C/07/EN (CM44x) or TI01112C/07/EN (CM44xR)

10 Technical data

10.1 Input

Measured variables	Turbidity Temperature
---------------------------	--------------------------

Measuring ranges	CUS52D		Application
	Turbidity	0.000 to 4000 FNU Display range up to 9999 FNU	Formazin
	Temperature	-20 to +85 °C (-4 to +185 °F)	

For measuring range up to 10 FNU, the sensor exhibits a detection limit (LOD) of 0.0015 FNU (measured in accordance with ISO 15839).

10.2 Performance characteristics

Measured error 2% ±0.01 FNU; reference: factory calibration

Wavelength 860 nm

Conformity Determining turbidity in accordance with ISO 7027

Factory calibration The sensor has been calibrated in the factory for "formazin" applications.
Basis: internal 20-point characteristic curve

Applications The formazin factory calibration is used as the basis for precalibrating additional applications and optimizing them for the different media characteristics.

Application: water	Recommended operating ranges	Max. display range
Factory calibration for formazin	0.000 to 4000 FNU	0.000 to 9999 FNU
Application: Kaolin	0 to 600 mg/l	0 to 3 g/l
Application: PSL	0 to 500 度	0 to 3000 度
Application: diatomite	0 to 2200 mg/l	0 to 10 g/l

To adapt to a specific application, customer calibrations can be carried out with up to 6 points.

Drift Working on the basis of electronic controls, the sensor is largely free of drifts.

Detection limits	Application	Measuring range	Detection limit
	Formazin	0 to 10 FNU (ISO 15839)	0.0015 FNU

Response time >1 sec, adjustable

Repeatability < 0.5 % of measured value (measuring range : 0 to 10 FNU)

10.3 Environment

Ambient temperature range -20 to 60 °C (-4 to 140 °F)

Storage temperature -20 to 70 °C (-4 to 158 °F)

Degree of protection IP 68 (test condition: 1.8 m (5.91 ft) water column over 20 days, 1 mol/l KCl)

10.4 Process

Process temperature -20 to 85 °C (-4 to 185 °F)

Process pressure 0.5 to 10 bar (7 to 145 psi) absolute

Minimum flow No minimum flow necessary.
For solids which have a tendency to form deposits, ensure that sufficient mixing is performed.

10.5 Mechanical construction

Dimensions See "Installation conditions"

Weight Sensor with 7 m cable

With clamp	approx. 1.56 kg
Without clamp	approx. 1.48 kg

Materials

Sensor	Stainless steel 1.4404 (AISI 316 L)
Optical windows	Sapphire
O-rings	EPDM

Process connections G1 and NPT 3/4"
2" clamp (depends on sensor version)/ DIN 32676

Index

A

Accessories	35
Ambient temperature range	40
Applications	21, 39
Assemblies	35
Assembly adjustment	23

B

Bubble trap	37
-------------------	----

C

Calibration	22
Calibration set	37
Cleaning	33
Connection	
Transmitter	19
Cyclic cleaning	30

D

Damping	30
Declaration of Conformity	6
Degree of protection	40
Designated use	4
Dimensions	7
Disposal	34

E

Electrical technician	19
Electromagnetic compatibility	4

F

Factor	29
Factory calibration	22
Filter monitoring	28

H

Holder	36
--------------	----

I

Immersion operation	17
Incoming acceptance	6
Input	
Measured variables	38
Measuring ranges	38
Installation	7
Installation examples	12
Installation instructions	9

M

Maintenance	33
Materials	40
Measured error	39
Measured variables	38
Measuring principle	20
Measuring ranges	38
Measuring system	9
Minimum flow	40
Mounting material	35
Multipoint calibration	24

N

Nameplate	6
-----------------	---

O

Occupational safety	4
Offset	29
Operational safety	4

P

Performance characteristics	
Applications	39
Measured error	39
Wavelength	39
Pipe installation	15
Post-connection check	19
Post-installation check	18
Process pressure	40
Process temperature	40
Product identification	6
Product safety	5

R

Requirements for personnel	4
Return	34

S

Safety instructions	4
Scope of delivery	6
Selecting the applications	23
Sensor design	20
Signal filter	30
Single-point calibration	24
Solid state reference	31
Spare parts kits	34
Storage temperature	40

T

Technical data	38
Transmitter	37
Transmitter connection	19

U

Ultrasonic cleaning	36
Use	4

W

Wavelength	39
Weight	40
Wiring	19



71237021

www.addresses.endress.com
