



Level



Pressure



Flow



Temperature



Liquid
Analysis



Registration



Systems
Components



Services



Solutions

Operating Instructions

Smartec S CLD132

Conductivity Measuring System

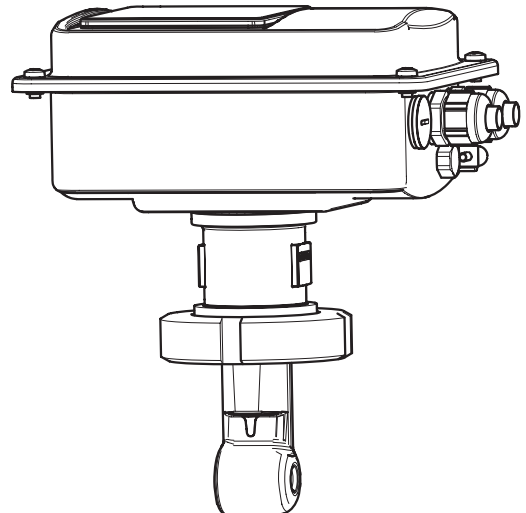
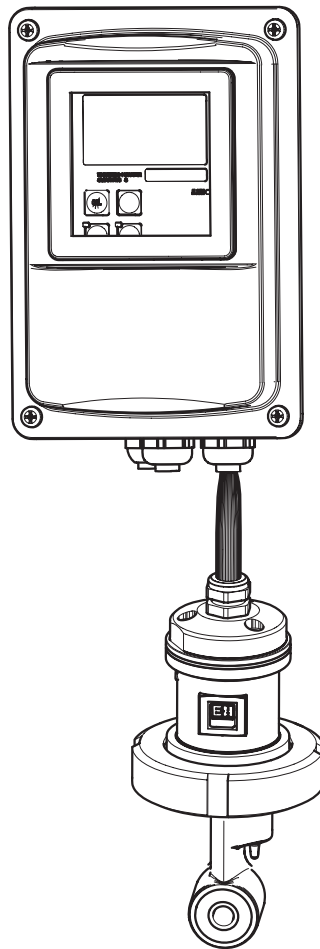

Brief overview

This overview explains how to use these Operating Instructions to commission your measuring system quickly and safely.

	Safety instructions
→ Page 5 ff. → Page 6 ff.	General safety instructions Explanation of the warning symbols You can find special instructions at the appropriate position in the chapter in question. The significance is indicated with the icons Warning ⚠, Caution ⚡ and Note 📌.
	▼
	Installation
→ Page 10 ff. → Page 15 ff.	Here, you can find information on installation conditions and the dimensions of the measuring system. These pages explain how to install the measuring system
	▼
	Wiring
→ Page 18 ff.	Here, you can find out how to connect your measuring system. You also find information on how to connect the CLS52 sensor if you are using a separate version.
	▼
	Operation
→ Page 23 → Page 26 → Page 33 ff. → Page 51 ff.	The display and operating elements are described here. The operating concept is described here. The system configuration is explained here. You can find information on how to calibrate the sensor here.
	▼
	Maintenance
→ Page 54 ff. → Page 59 ff. → Page 61 ff. → Page 67 ff.	Here, you can find information on the maintenance of the measuring point. Accessories which can be supplied for the measuring system are listed on the pages indicated. Use the trouble-shooting information given here if your system should not work properly. Spare parts that can be delivered and a system overview are listed on these pages.
	▼
	Technical data
→ Page 73 → Page 73 ff.	Dimensions Process conditions, weight, material
	▼
	Index
→ Page 80 ff.	The index helps you to find information and important terms easily and quickly.

Table of contents

1	Safety instructions	5		
1.1	Designated use	5		
1.2	Installation, commissioning and operation	5		
1.3	Operational safety	5		
1.4	Return	6		
1.5	Notes on safety conventions and symbols	6		
2	Identification	7		
2.1	Device designation	7		
2.1.1	Nameplate	7		
2.1.2	Product structure Smartec S CLD132	7		
2.1.3	Basic version and function extensions	8		
2.2	Scope of delivery	8		
2.3	Certificates and approvals	8		
3	Installation	9		
3.1	Quick installation guide	9		
3.1.1	Measuring system	9		
3.2	Incoming acceptance, transport, storage	10		
3.3	Installation conditions	10		
3.3.1	Notes on installation	10		
3.3.2	CLD132 separate version	11		
3.3.3	CLD 132 compact version	13		
3.4	Installation instructions	15		
3.4.1	Mounting CLD132 separate version	15		
3.4.2	Mounting CLD132 compact version or CLS52 sensor for separate version	16		
3.5	Post-installation check	17		
4	Wiring	18		
4.1	Electrical connection	18		
4.1.1	Electrical connection of transmitter	18		
4.2	Post-connection check	22		
5	Operation	23		
5.1	Quick operation guide	23		
5.2	Display and operating elements	23		
5.2.1	Display	23		
5.2.2	Operating elements	24		
5.2.3	Key assignment	24		
5.3	Local operation	26		
5.3.1	Operating concept	26		
6	Commissioning	28		
6.1	Function check	28		
6.2	Start-up	28		
6.3	Quick setup	30		
6.4	Instrument configuration	33		
6.4.1	Setup 1 (conductivity, concentration)	33		
6.4.2	Setup 2 (temperature)	34		
6.4.3	Current outputs	36		
6.4.4	Alarm	37		
6.4.5	Check	38		
6.4.6	Relay configuration	39		
6.4.7	Temperature compensation with table	41		
6.4.8	Concentration measurement	42		
6.4.9	Service	45		
6.4.10	E+H Service	46		
6.4.11	Interfaces	47		
6.4.12	Determining the temperature coefficient	48		
6.4.13	Remote parameter set switching (measuring range switching, MRS)	48		
6.4.14	Calibration	51		
6.5	Communication interfaces	53		
7	Maintenance	54		
7.1	Maintenance of Smartec S CLD132	54		
7.1.1	Dismantling Smartec S CLD132	54		
7.1.2	Special case: replacement of central module	55		
7.2	Maintenance of measuring system	56		
7.2.1	Cleaning conductivity sensors	56		
7.2.2	Checking inductive conductivity sensors	56		
7.2.3	Instrument check by medium simulation	57		
7.2.4	Checking line extension and junction box	58		
7.3	Service equipment "Optoscope"	58		
8	Accessories	59		
8.1	Sensors	59		
8.2	Extension cable	59		
8.3	Junction box	59		
8.4	Post mounting kit	60		
8.5	Software upgrade	60		
8.6	Calibration solutions	60		
8.7	Optoscope	60		
9	Troubleshooting	61		
9.1	Troubleshooting instructions	61		
9.2	System error messages	61		
9.3	Process-specific errors	62		
9.4	Instrument-specific errors	65		
9.5	Spare parts	67		
9.5.1	Exploded view	68		
9.5.2	Spare part kits	69		
9.6	Return	70		
9.7	Disposal	70		

10	Technical Data	71
10.1	Input	71
10.2	Output	71
10.3	Power supply	72
10.4	Performance characteristics	72
10.5	Environment	72
10.6	Mechanical construction	73
10.7	Measurement data of CLS52 sensor	73
10.8	Process	73
10.9	Chemical durability of CLS52 sensor	75
10.10	Documentation	75
11	Appendix	76
	Index	80

1 Safety instructions

1.1 Designated use

Smartec S CLD132 is a field-tested and reliable transmitter used to determine the conductivity of liquid media.

It is particularly suitable for use in the foodstuffs industry.

Any other use than the one described here compromises the safety of persons and the entire measuring system and is, therefore, not permitted.

The manufacturer is not liable for damage caused by improper or non-designated use.

1.2 Installation, commissioning and operation

Please note the following items:

- Installation, commissioning, operation and maintenance of the measuring system must only be carried out by trained technical personnel.
The technical personnel must be authorised for the specified activities by the system operator.
- Electrical connection must only be carried out by a certified electrician.
- Technical personnel must have read and understood these Operating Instructions and must adhere to them.
- Before commissioning the entire measuring point, check all the connections for correctness. Ensure that electrical cables and hose connections are not damaged.
- Do not operate damaged products and secure them against unintentional commissioning. Mark the damaged product as being defective.
- Measuring point faults may only be rectified by authorised and specially trained personnel.
- If faults can not be rectified, the products must be taken out of service and secured against unintentional commissioning.
- Repairs not described in these Operating Instructions may only be carried out at the manufacturer's or by the service organisation.

1.3 Operational safety

The transmitter has been designed and tested according to the state of the art and left the factory in perfect functioning order.

Relevant regulations and European standards have been met.

As the user, you are responsible for complying with the following safety conditions:

- Installation instructions
- Local prevailing standards and regulations.

Immunity to interference

This instrument has been tested for electromagnetic compatibility in industrial use according to applicable European standards. It is protected against electromagnetic interference by the following design measures:

- cable screening
- interference suppression filter
- interference suppression capacitors.

Protection against interference as specified above is valid only for an instrument connected according to the instructions in these Operating Instructions.

1.4 Return

If the transmitter has to be repaired, please return it *cleaned* to the sales centre responsible. Please use the original packaging, if possible.

Please enclose the completed "Declaration of contamination" (copy the second last page of these Operating Instructions) with the packaging and the transportation documents.

No repair without completed "Declaration of contamination"!

1.5 Notes on safety conventions and symbols

Safety symbols



Warning!

This symbol alerts you to hazards. They can cause serious damage to the instrument or to persons if ignored.



Caution!

This symbol alerts you to possible faults which could arise from incorrect operation. They could cause damage to the instrument if ignored.



Note!

This symbol indicates important items of information.

Electrical symbols



Direct Current (DC)

A terminal at which DC is applied or through which DC flows.



Alternating Current (AC)

A terminal at which (sine-form) AC is applied or through which AC flows.



Ground connecting

A terminal, which, from the user's point of view, is already grounded using a grounding system.



Protective earth terminal

A terminal which must be grounded before other connections may be set up.



Equipotential connection

A connection which must be connected to the grounding system of the equipment. This can be, i.e., a potential matching line of a star-shaped grounding system, depending on national or company practice.



Protective insulation

The equipment is protected by double insulation.



Alarm relay



Input



Output



Constant voltage source



Temperature sensor

2 Identification

2.1 Device designation

2.1.1 Nameplate

Compare the order code on the nameplate (on the Smartec) with the product structure (see below) and check that it agrees with your order.

You can identify the instrument variant by the order code on the nameplate. Under "Codes", you can find the release code for the software upgrade "MRS".

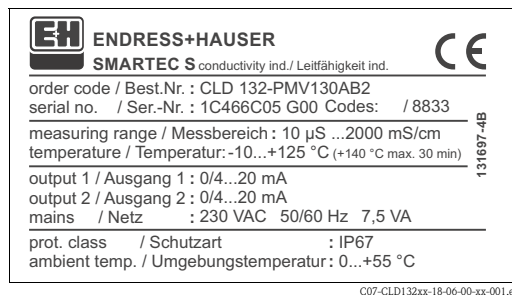

Fig. 1: Nameplate CLD132 (example)

2.1.2 Product structure Smartec S CLD132

Version	
P	Compact version
S	Separate transmitter, cable length 20 m / 65.62 ft
W	Separate transmitter, cable length 5 m / 16.41 ft
X	Separate transmitter, cable length 10 m / 32.81 ft
Process connection	
MV1	Dairy fitting DN 50 (acc. to DIN 11851)
CS1	Clamp connection 2" (acc. to ISO 2852)
GE1	Internal thread G 1 1/2
VA1	Varivent connection DN 40 ... 125
AP1	APV connection DN 40 ... 100
SMS	SMS connection 2"
Cable entry	
1	Cable gland Pg 13.5
3	Cable gland M 20 x 1.5
5	Conduit adapter NPT 1/2 "
Power supply	
0	230 V AC
1	115 V AC
5	100 V AC
8	24 V AC / DC
Current output / communication	
AA	Current output conductivity, without communication
AB	Current output conductivity and temperature, without communication
HA	HART, current output conductivity
HB	HART, current output conductivity and temperature
PE	PROFIBUS-PA, no current output
PF	PROFIBUS-PA, M 12 connector, no current output
PP	PROFIBUS-DP, no current output
Additional features	
1	Basic version with fast temperature measurement
2	Remote parameter set switching with fast temperature measurement
6	Basic version with encapsulated Pt 100 for high loads
7	Remote parameter set switching with encapsulated Pt 100 for high loads
CLD132-	complete order code

2.1.3 Basic version and function extensions

Functions of the basic version	Options and their functions
<ul style="list-style-type: none"> ■ Measurement ■ Calibration of cell constant ■ Calibration of residual coupling ■ Calibration of installation factor ■ Read instrument parameters ■ Linear current output ■ Current output simulation ■ Service functions ■ Temperature compensation selectable (e.g. 1 free coefficient table) ■ Concentration measurement selectable (4 defined curves, 1 free table) ■ Relay as alarm contact 	<ul style="list-style-type: none"> ■ Second current output for temperature (hardware option) ■ HART communication ■ PROFIBUS communication <p>Remote parameter set switching (software option):</p> <ul style="list-style-type: none"> ■ Remote switching of max. 4 parameter sets (measuring ranges) ■ Temperature coefficients can be determined ■ Temperature compensation selectable (e.g. 4 free coefficient tables) ■ Concentration measurement selectable (4 defined curves, 4 free tables) ■ Check of measuring system by PCS alarm (live check) ■ Relay can be configured as alarm or limit contact

2.2 Scope of delivery

The scope of delivery of the compact version includes:

- Smartec S CLD132 compact measuring system with integrated sensor
- Terminal strip set
- Expansion bellows (-*GE1***** versions only)
- Operating Instructions BA 207C/07/en
- Versions with HART communication only:
 - Operating Instructions Field communication with HART, BA 212C/07/en
- Versions with PROFIBUS interface only:
 - Operating Instructions Field communication with PROFIBUS, BA 213C/07/en
 - M12 connector (-*****PF* versions only)

The scope of delivery of the separate version includes:

- Smartec S CLD132 transmitter
- CLS52 inductive sensor with fixed cable
- Terminal strip set
- Expansion bellows (-*GE1***** versions only)
- Operating Instructions BA 207C/07/en
- Versions with HART communication only:
 - Operating Instructions Field communication with HART, BA 212C/07/en
- Versions with PROFIBUS interface only:
 - Operating Instructions Field communication with PROFIBUS, BA 213C/07/en
 - M12 connector (-*****PF* versions only)

2.3 Certificates and approvals

Declaration of conformity

The product meets the legal requirements of the harmonised European standards.
 The manufacturer confirms compliance with the standards by affixing the **CE** symbol.

3 Installation

3.1 Quick installation guide

The following procedure should be followed for a complete measuring point installation:

Compact version:

- Perform an Airset. Install the compact version at the measuring point (see chapter "Mounting CLD132 compact version").
- Connect the compact version as described in the chapter "Electrical connection".
- Start up the compact version as described in the chapter "Commissioning".

Separate version:

- Mount the transmitter (see chapter "Mounting CLD132 separate version").
- If you have not yet installed the sensor at the measuring point, perform an Airset and install the sensor (see the Technical Information of the sensor).
- Connect the sensor to the Smartec S CLD132 as described in the chapter "Electrical connection".
- Connect the transmitter as described in the chapter "Electrical connection".
- Start up the Smartec S CLD132 as described in the chapter "Commissioning".

3.1.1 Measuring system

The complete measuring system comprises:

- the Smartec S CLD132 transmitter
- the conductivity sensor Indumax H CLS52 with an integrated temperature sensor and a fixed cable
- or
- the compact version with an integrated conductivity sensor

Optional for the separate version: CLK5 extension cable, VBM junction box, mounting kit for pipe installation (see chapter "Accessories")

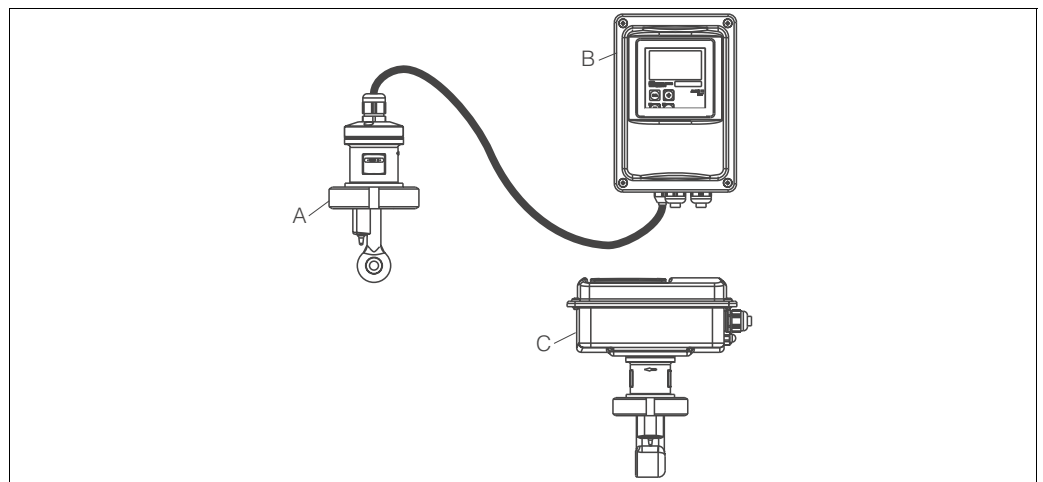

Fig. 2: Complete measuring systems Smartec S CLD132 as a separate transmitter and compact version with integrated conductivity sensor

- A CLS52 conductivity sensor
- B Smartec S CLD132
- C Smartec S CLD132 as compact version with integrated conductivity sensor

3.2 Incoming acceptance, transport, storage

- Make sure the packaging is undamaged!
Inform the supplier about damage to the packaging.
Keep the damaged packaging until the matter has been settled.
- Make sure the contents are undamaged!
Inform the supplier about damage to the delivery contents.
Keep the damaged products until the matter has been settled.
- Check that the scope of delivery is complete and agrees with your order and the shipping documents.
- The packaging material used to store or to transport the product must provide shock protection and humidity protection. The original packaging offers the best protection. Also, keep to the approved ambient conditions (see "Technical data").
- If you have any questions, please contact your supplier or your sales centre responsible.

3.3 Installation conditions

3.3.1 Notes on installation

Airset

Perform an Airset before sensor installation (see chapter "Calibration"). Make sure that the instrument is ready for operation, i.e. mains and sensor are connected.

Wall distance

The sensor's distance from the pipe wall affects the measuring accuracy (see Fig. 4).

In narrow installation conditions, the ion flow in the medium is affected by the pipe walls. This effect is compensated by the so-called installation factor.

When the distance from the wall is sufficient, i.e. $a > 15 \text{ mm} / 0.59 \text{ inch}$, the installation factor can be ignored ($f = 1.00$). When the wall distance is lower, the installation factor increases in the case of electrically insulating pipes ($f > 1$) while it decreases for electrically conductive pipes ($f < 1$); see Fig. 4.

The determination of the installation factor is described in the chapter "Calibration".

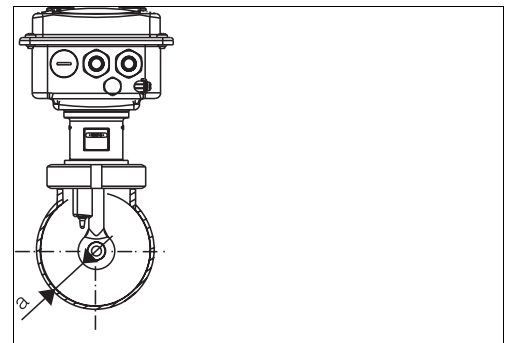

Fig. 3: Installation CLD132 compact version

a Wall distance

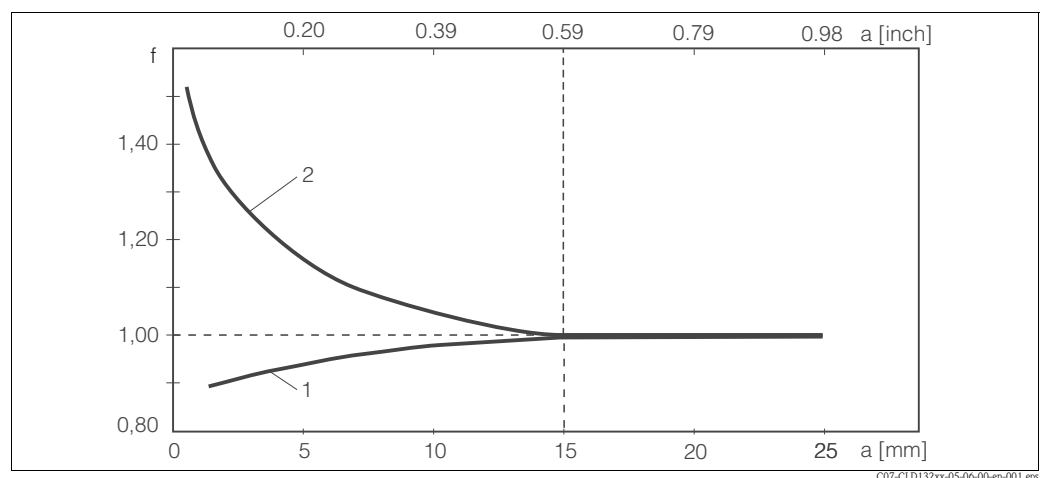

Fig. 4: Relationship between installation factor and distance from wall a

- 1 Electrically conductive pipe wall
- 2 Insulating pipe wall

3.3.2 CLD132 separate version

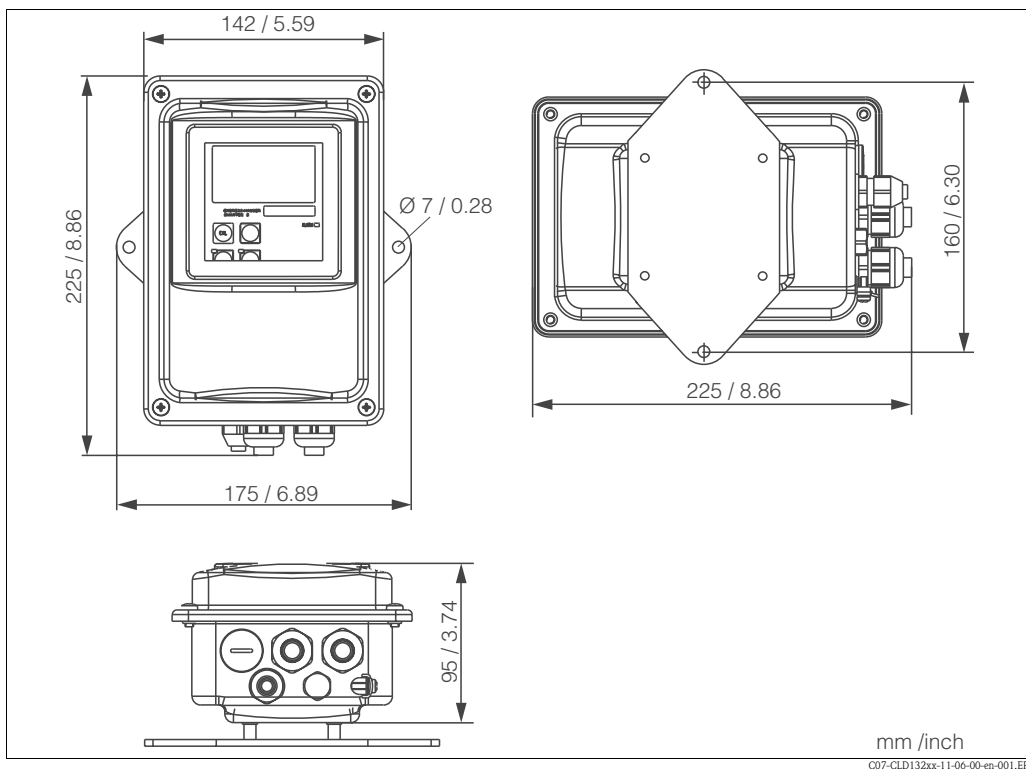

Fig. 5: CLD132 wall mounting with mounting plate

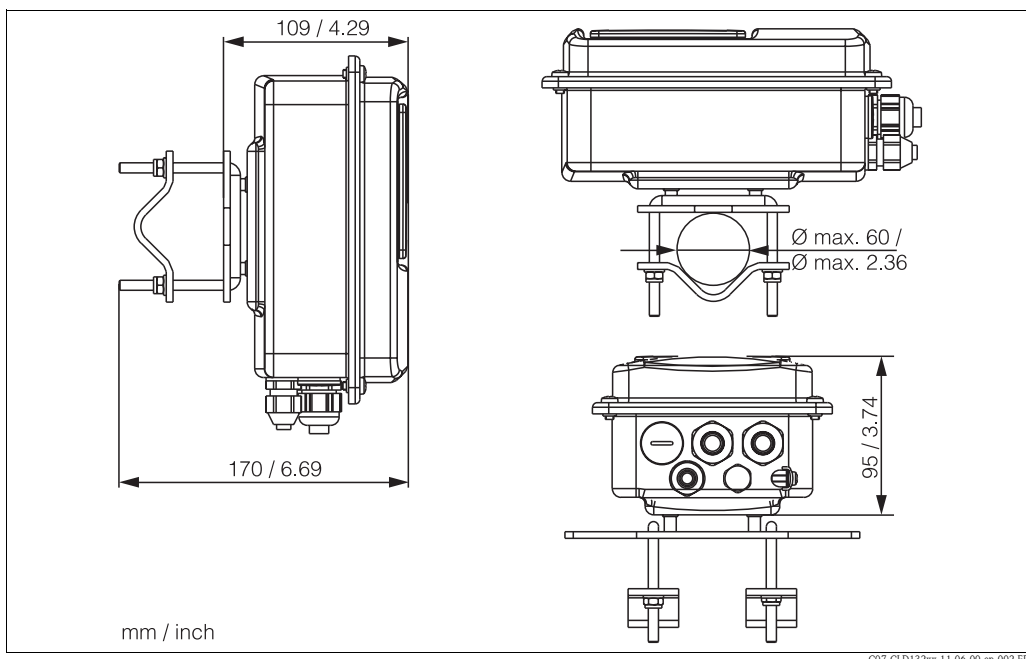

Fig. 6: CLD132 mounting on pipes (Ø 60 mm / 2.36")

Conductivity sensors for the separate transmitter

CLS52 conductivity sensors with various process connections covering all common installation conditions are available for the separate version.



Note!

Perform an Airset and calibrate the sensor before sensor installation.

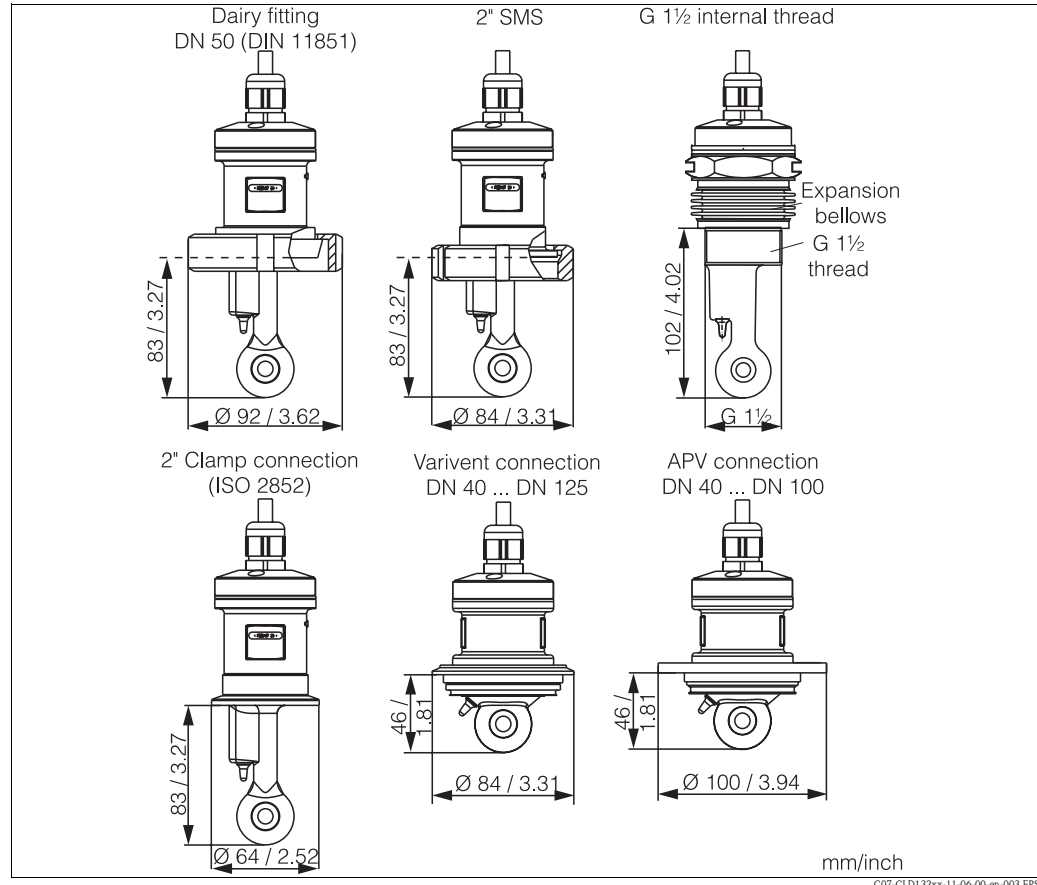

Fig. 7: Process connections for CLS52 conductivity sensor



Note!

■ Clamp connection

Sensors with clamp connections can be fixed using sheet metal brackets or solid brackets.

Sheet metal brackets have a lower dimensional stability, uneven bearing surfaces causing point loads and sometimes sharp edges that can damage the clamp.

We **strongly** recommend to always use solid brackets because of their higher dimensional stability. Solid brackets may be applied over the total pressure-temperature range (see diagram on page 5).

■ Threaded connection

Sensors with threaded connections are supplied with expansion bellows (compensator) to be able to align them in flow direction. The two O-rings (Viton) of the expansion bellows have no sealing function and are not in contact with medium. The process is usually sealed off by PTFE tape on the G 1½ thread.

Measuring range

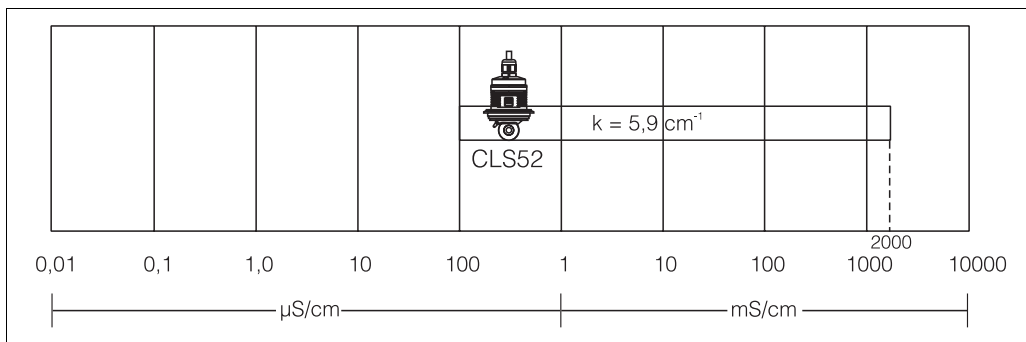

Fig. 8: CLS52 measuring range

3.3.3 CLD 132 compact version

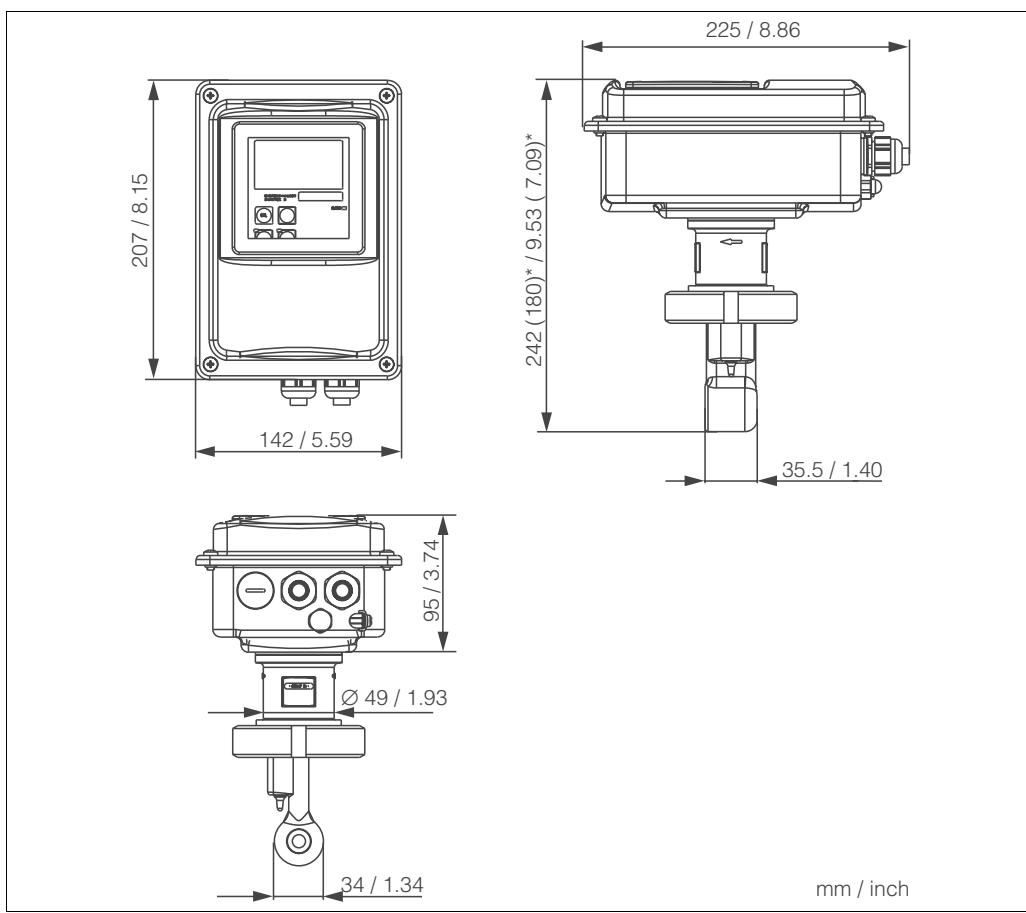

Fig. 9: Dimensions of CLD132 compact version

Connection variants

Various process connections covering all common installation conditions are available for the compact version.

The compact version is installed at the measuring point with the required process connection.

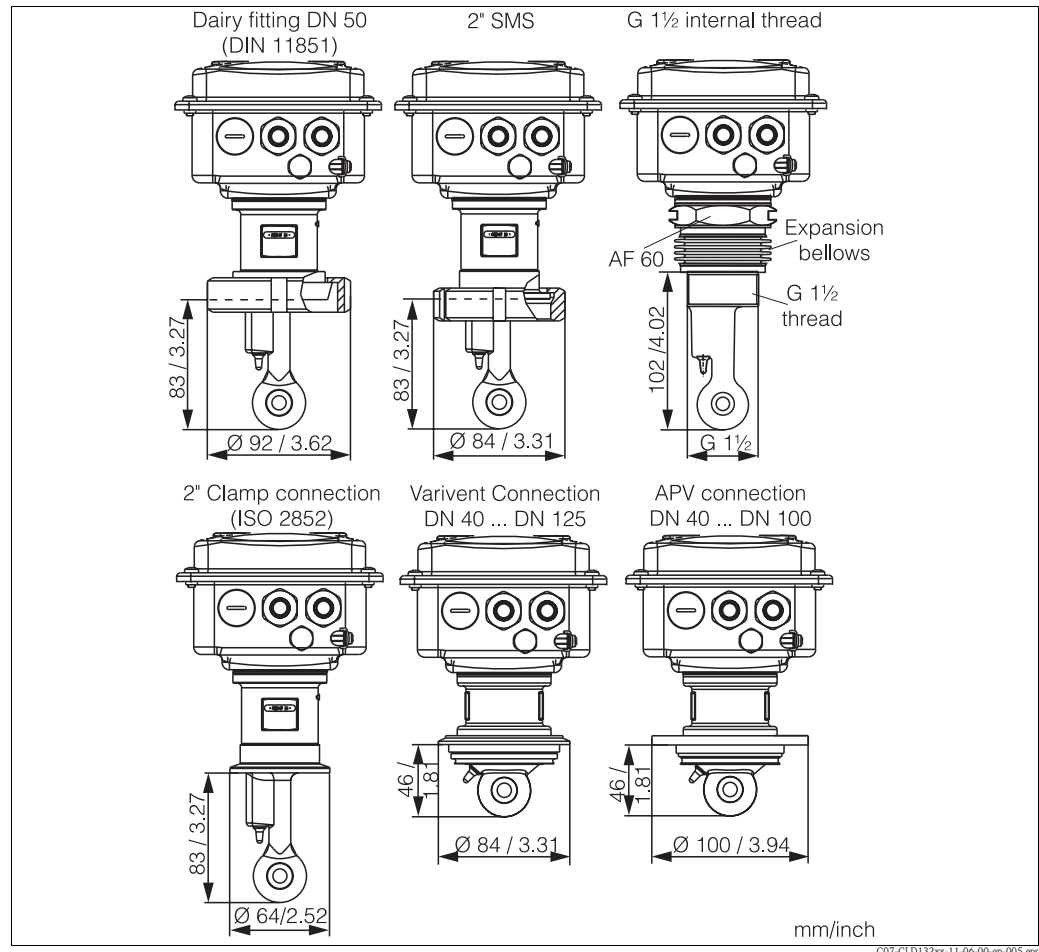

Fig. 10: Process connections for the CLD132 compact version



Note!

■ Clamp connection

Sensors with clamp connections can be fixed using sheet metal brackets or solid brackets. Sheet metal brackets have a lower dimensional stability, uneven bearing surfaces causing point loads and sometimes sharp edges that can damage the clamp.

We **strongly** recommend to always use solid brackets because of their higher dimensional stability. Solid brackets may be applied over the total pressure-temperature range (see diagram on page 5).

■ Threaded connection

Sensors with threaded connections are supplied with expansion bellows (compensator) to be able to align them in flow direction. The two O-rings (Viton) of the expansion bellows have no sealing function and are not in contact with medium. The process is usually sealed off by PTFE tape on the G 1½ thread.

3.4 Installation instructions

3.4.1 Mounting CLD132 separate version

Wall mounting

For wall mounting, attach the mounting plate to the wall by drilling holes as required. Anchors and screws are to be provided by the operator.

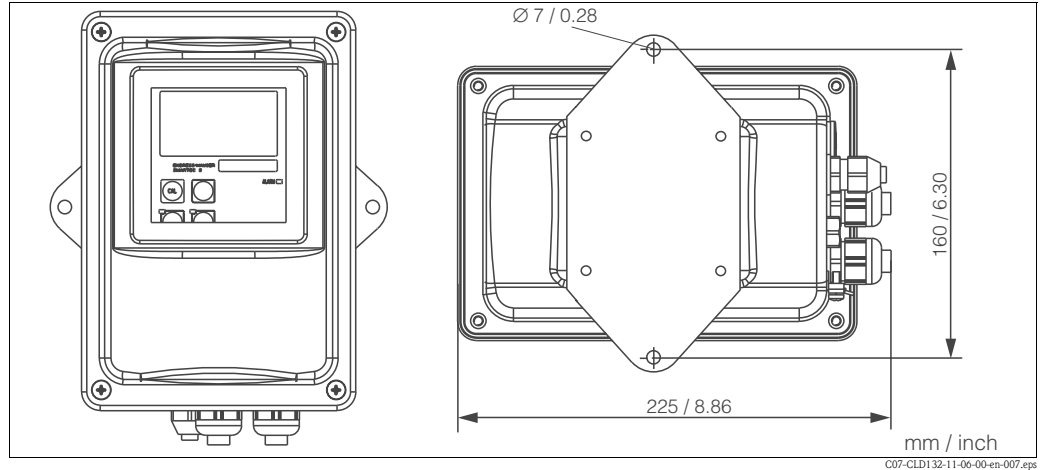

Fig. 11: Wall mounting of CLD132 separate version

Post mounting

A mounting kit for installing the housing on horizontal or vertical posts or pipes (max. Ø 60 mm / Ø 2.36") is available as an accessory (see chapter "Accessories").

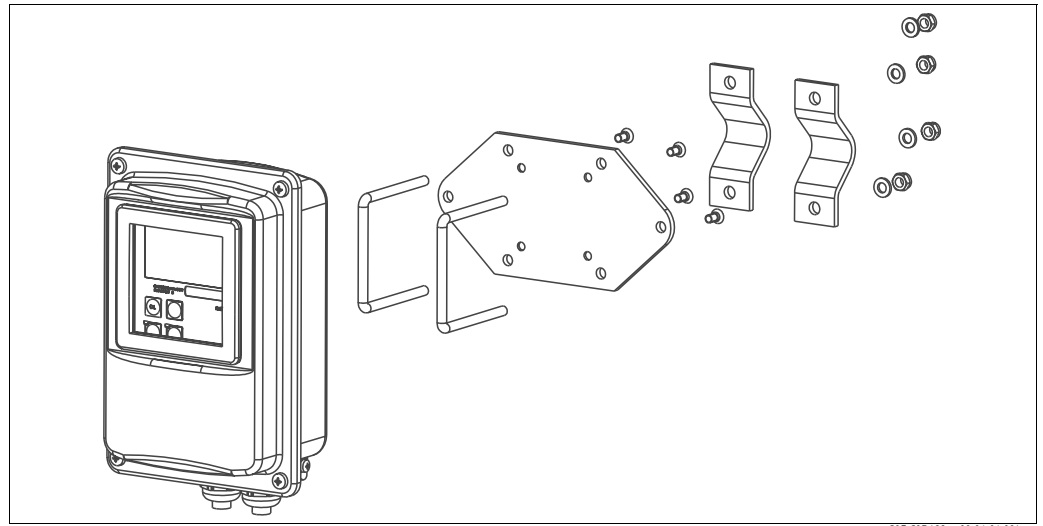

Fig. 12: Mounting kit for installing the CLD132 separate version on posts

1. Remove the mounting plate.
2. Insert the holding bars through the pre-drilled holes of the mounting plate and screw the mounting plate onto the transmitter.
3. Use the brackets to install the Smartec S on the post or pipe (Fig. 13).

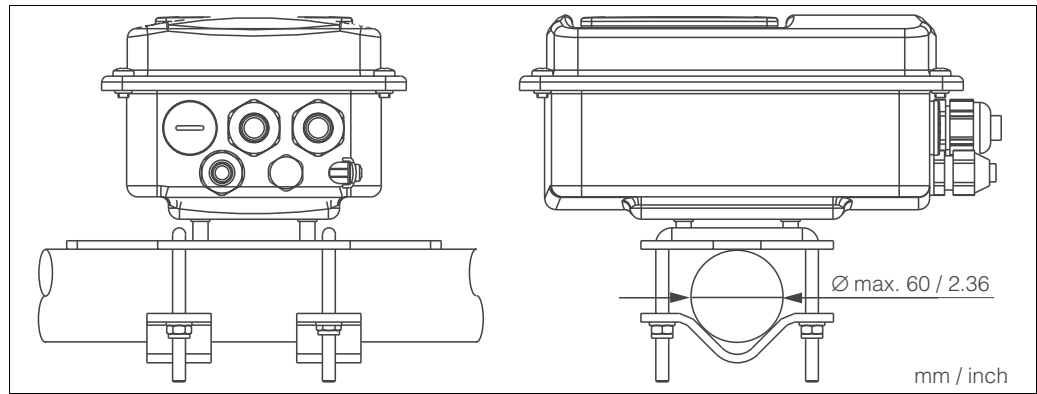

Fig. 13: Post mounting of CLD132 separate version

3.4.2 Mounting CLD132 compact version or CLS52 sensor for separate version

Install the compact version or the CLS52 sensor directly on the pipe or vessel socket via the process connection (depending on ordered version).



Note!

Perform an Airset and calibrate the sensor before installing the compact version or the sensor.

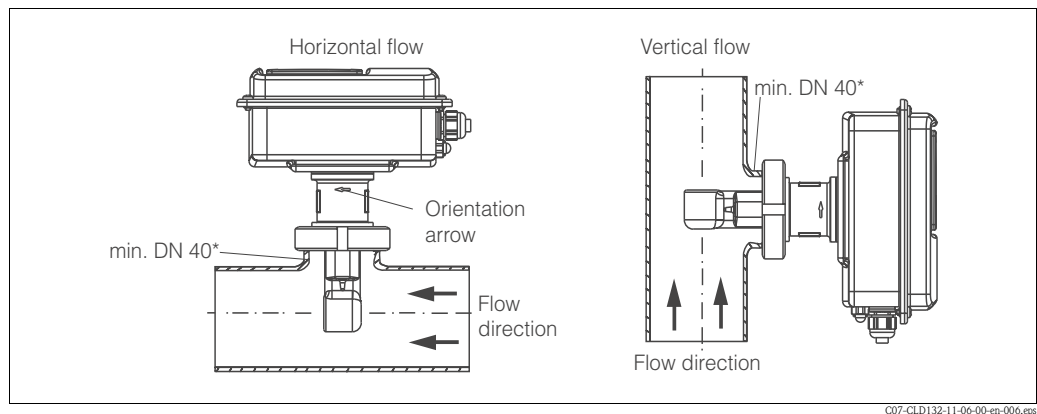

Fig. 14: Installation of CLD132 compact version

1. When installing the Smartec S CLD132 or the sensor, make sure that the flow opening of the sensor is oriented in the flow direction of the medium. An orientation arrow on the sensor facilitates orientation (see Fig. 14 above).
2. Tighten the flange.
3. For versions with internal thread G 1½, expansion bellows are supplied for length compensation. Thus, the sensor can always be oriented in flow direction.



Note!

- Choose the immersion depth of the sensor in the medium such that the coil body is completely immersed.
- Please observe the notes on the wall distance in the chapter "Installation conditions".
- Please observe the limits for the medium and ambient temperature when using the compact version (see chapter "Technical data").

Sensor positioning: compact version

The sensor in the compact housing must be oriented in the flow direction.

If you need to reorient the sensor in relation to the housing, proceed as follows:

1. Remove the cover.
2. Loosen the screws of the electronics box and carefully remove the box from the housing.
3. Loosen the three sensor fastening screws until the sensor can be turned.
4. Align the sensor and tighten the screws. Do not exceed the maximum torque of 1.5 Nm!
5. Reassemble the transmitter housing in reverse sequence of operations.



Note!

For exact positions of the electronics box and the sensor screws, see the exploded view in the chapter "Spare parts".

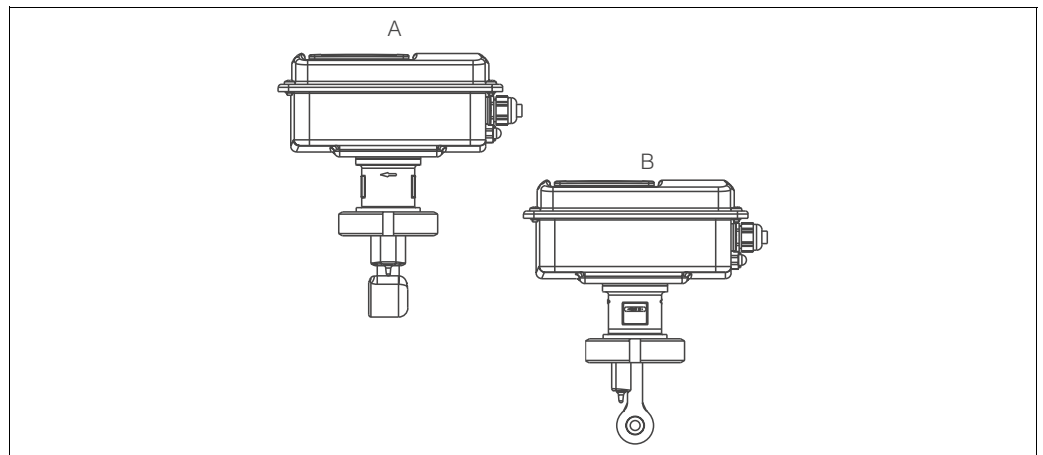

Fig. 15: Sensor orientation in the transmitter housing

- A Standard orientation
B Sensor turned by 90°

3.5 Post-installation check

- After installation, check the measuring system for damages.
- Check the sensor orientation to the flow direction of the medium.
- Check that the coil body of the sensor is completely immersed in the medium.

4 Wiring

4.1 Electrical connection



Warning!

- The electrical connection must only be carried out by a certified electrician.
- Technical personnel must have read and understood the instructions in this manual and must adhere to them.
- Ensure that there is no voltage at the power cable before beginning the connection work.

4.1.1 Electrical connection of transmitter

Proceed as follows to connect the Smartec S CLD132:

1. Loosen the 4 Phillips screws on the housing cover and remove the cover.
2. Remove the cover frame from the terminal blocks. To do this, introduce a screwdriver in the recess (①) according to Fig. 16 and push the tab inward (②).



Warning!

Do not remove the cover frame while the instrument is energised!

3. Thread the cables through the open cable glands into the housing according to the terminal assignments in Fig. 17.
4. Connect the power wires according to the terminal assignments in Fig. 18.
5. Connect the alarm contact according to the terminal assignments in Fig. 18.
6. Connect the housing ground.
7. Separate version: Connect the sensor according to the terminal assignments in Fig. 18.

In the case of the separate version, the conductivity sensor CLS52 is connected using the shielded multi-core special cable CLK5. Preparation instructions are supplied with the cable. Use junction box VBM (see chapter "Accessories") to extend the measuring cable. The maximum cable length if extended using a junction box is 55 m.

8. Tighten the cable glands firmly.

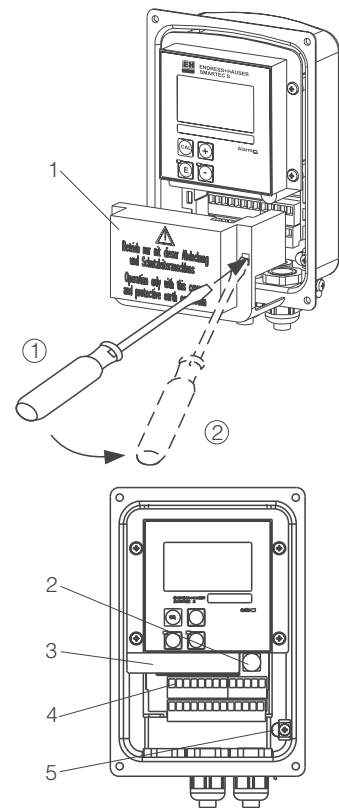

C07-CLD132xx-04-06-00-xx-001.eps

Fig. 16: View of housing with cover removed

- | | |
|---|---------------------------|
| 1 | Cover frame |
| 2 | Fuse |
| 3 | Removable electronics box |
| 4 | Terminals |
| 5 | Housing ground |

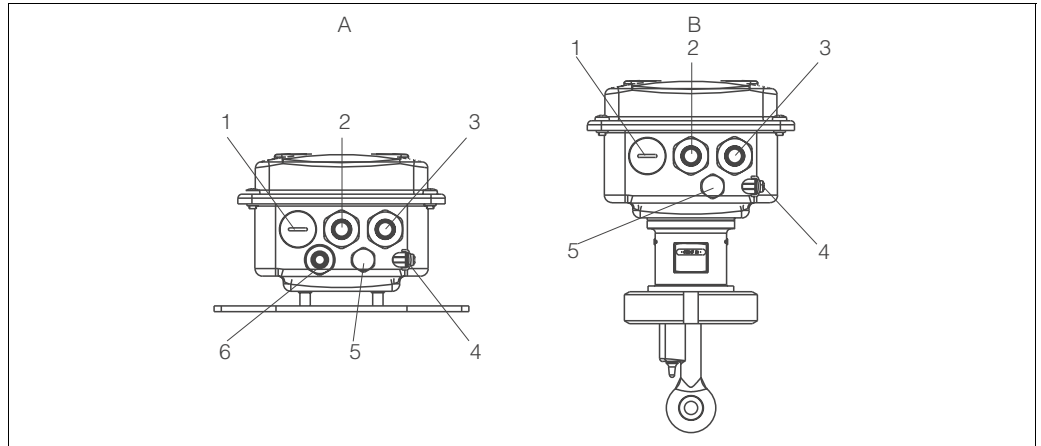

C07-CLD132xx-04-06-04-xx-001.eps

Fig. 17: Terminal assignments of cable glands on Smartec S CLD132

A Separate version

1 Plug, Pg 13.5, analog output, binary input

2 Cable gland for alarm contact, Pg 13.5

3 Cable gland for power supply, Pg 13.5

4 Housing ground

5 Pressure comp. element PCE (Goretex®- filter)

6 Cable gland for sensor connection, Pg 9

B Compact version

1 Plug, Pg 13.5, analog output, digital input

2 Cable gland for alarm contact, Pg 13.5

3 Cable gland for power supply, Pg 13.5

4 Housing ground

5 Pressure comp. element PCE (Goretex®- filter)

Wiring diagram

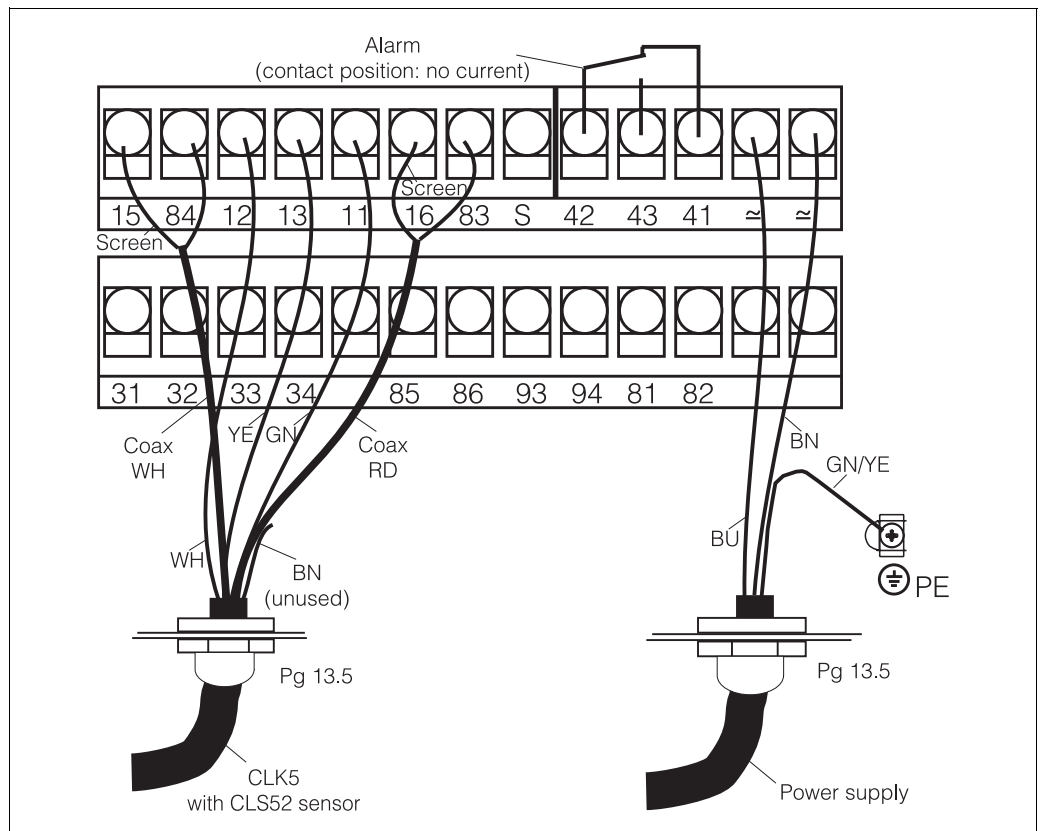

C07-CLD132xx-04-06-00-de-003.eps

Fig. 18: Electrical connection of Smartec S

Connection diagram

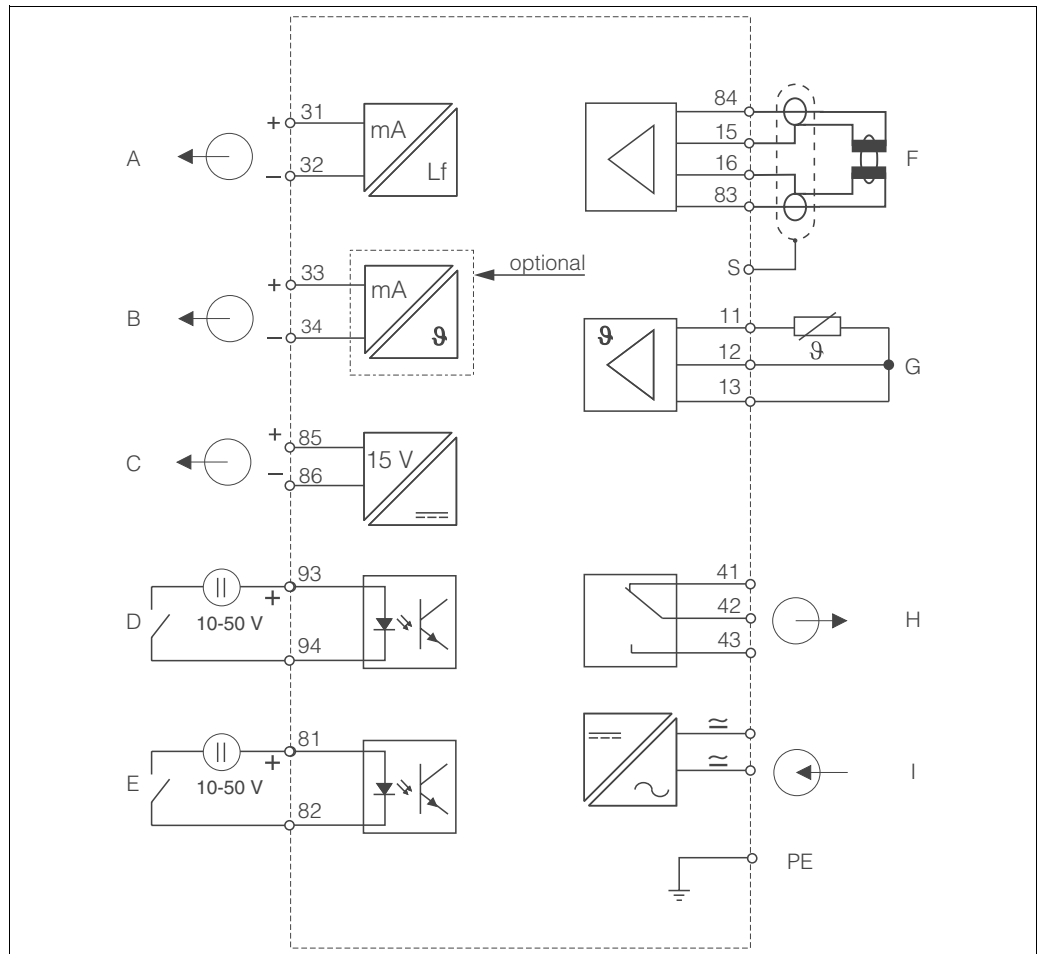

C07-CLD132xx-05-06-00-xx-003.eps

Fig. 19: Electrical connection of Smartec S CLD132

- | | | | |
|---|---------------------------------|-----|--|
| A | Signal output 1 conductivity | F | Conductivity sensor |
| B | Signal output 2 temperature | G | Temperature sensor |
| C | Auxiliary power output | H | Alarm (contact position: no current) |
| D | Binary input 2 (MRS1+2) | I | Power supply |
| E | Binary input 1 (hold / MRS 3+4) | MRS | Remote parameter set switching (measuring range switching) |

Connection of binary inputs

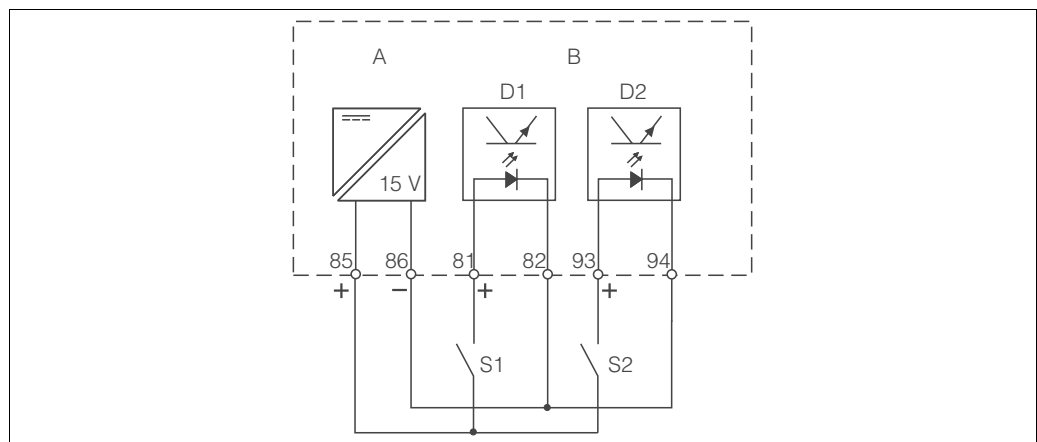

C07-CLD132xx-05-06-00-xx-004.eps

Fig. 20: Connection of binary inputs when using external contacts

- | | |
|----|----------------------------------|
| A | Auxiliary power output |
| B | Contact inputs D1 and D2 |
| S1 | External contacts, not energised |
| S2 | External contacts, not energised |

Connection compartment sticker

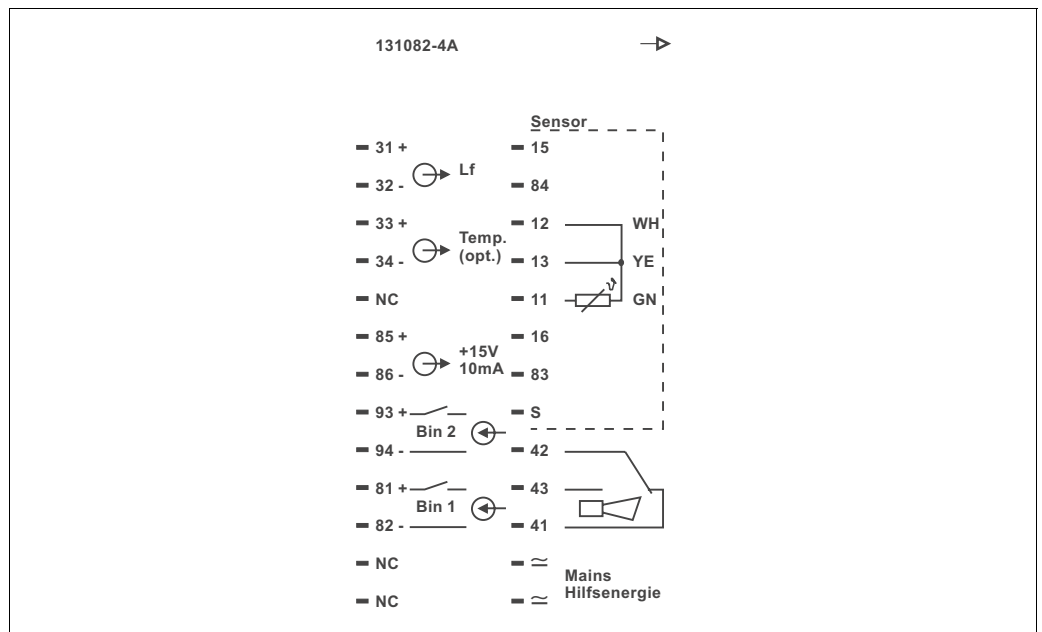

Fig. 21: Connection compartment sticker of Smartec S



Note!

The protection class of this instrument is I. The metal housing must be connected to PE.



Caution!

- Terminals designated as NC may not be switched.
- Undesignated terminals may not be switched.

Structure and termination of measuring cable

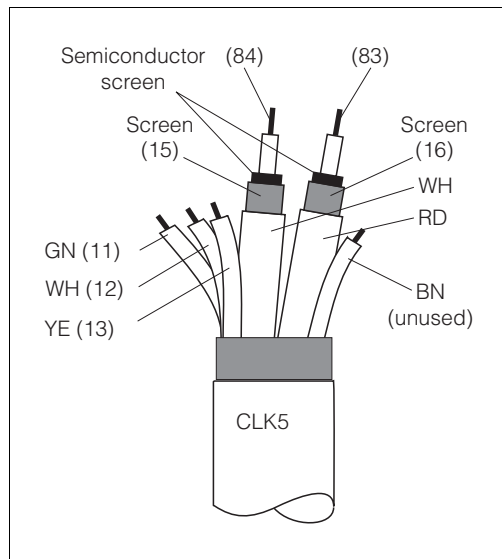

Fig. 22: Structure of CLK5 measuring cable

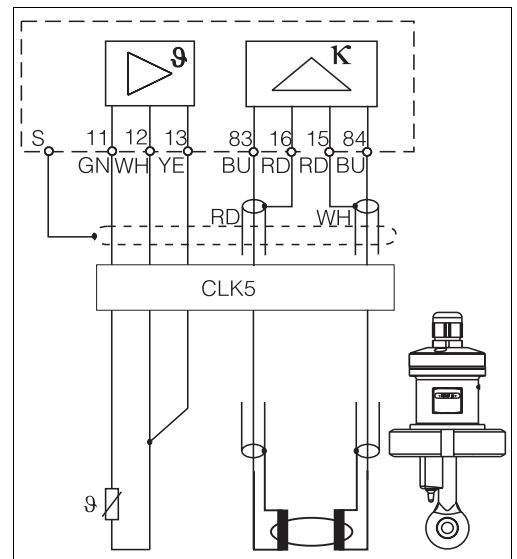

Fig. 23: Electrical connection of the CLS52 sensor for the separate version

4.2 Post-connection check

After wiring up the electrical connection, carry out the following checks:

Device status and specifications	Remarks
Are the transmitter or the cable externally damaged?	Visual inspection

Electrical connection	Remarks
Are the installed cables strain-relieved?	
No loops and cross-overs in the cable run?	
Are the signal cables correctly connected acc. to the wiring diagram?	
Are all screw terminals tightened?	
Are all cable entries installed, tightened and sealed?	
Are the PE distributor rails grounded (if present)?	Grounding at place of installation

5 Operation

5.1 Quick operation guide

You have the following options of operating Smartec S:

- Local operation via operating keys
- Via HART® interface (optional, for corresponding order version) via:
 - HART® hand-held terminal or
 - PC with HART® modem and Commuwin II software
- Via PROFIBUS PA/DP (optional, for corresponding order version)
 - PC with a corresponding interface and the Commuwin II software (see "Accessories") or via programmable logic controller (PLC).



Note!

For operation via HART or PROFIBUS PA/DP, read the corresponding chapters in the additional operating instructions:

- PROFIBUS PA/DP, field communication with Smartec S CLD132, BA 213C/07/en
- HART®, field communication with Smartec S CLD132, BA 212C/07/en

The following chapters describe local operation via operating keys.

5.2 Display and operating elements

5.2.1 Display

LED indicators

ALARM

Alarm indication for continuous limit violation, temperature sensor failure or system errors (see error list in chapter "Troubleshooting").

Liquid crystal display

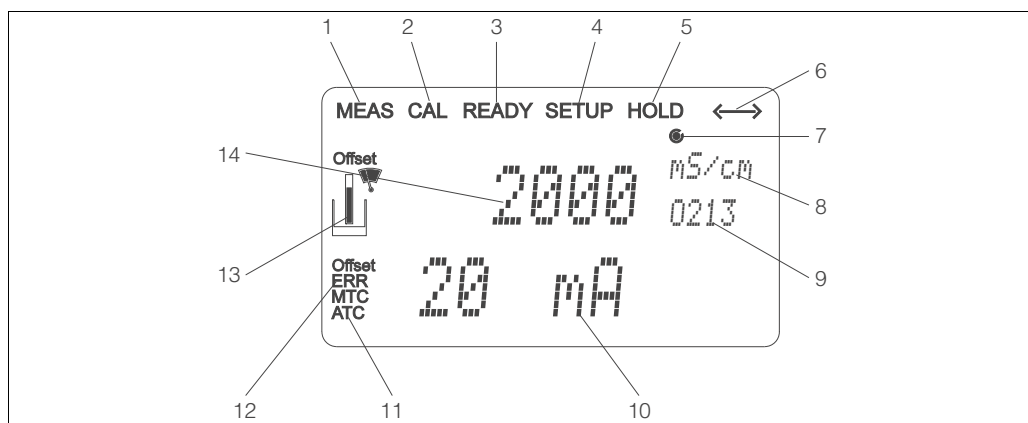

C07-CLD132xx-07-06-00-xx-001.eps

Fig. 24: LCD of Smartec S CLD132

- | | | | |
|---|--|----|---|
| 1 | Measuring mode indicator (normal operation) | 8 | In measuring mode: variable measured |
| 2 | Calibration mode indicator | | In setup mode: parameter adjusted |
| 3 | Calibration complete indicator | 9 | Function coding display |
| 4 | Setup mode indicator (configuration) | 10 | In measuring mode: secondary measured value |
| 5 | "Hold" mode indicator (outputs reflect last current status) | 11 | In setup / calibr. mode: e.g. parameter |
| 6 | Signal reception indicator for units with communication | 12 | Manual / automatic temperature compensation display |
| 7 | Indication of relay state: <input type="radio"/> inactive, <input checked="" type="radio"/> active | 13 | Error indicator |
| | | 14 | Sensor symbol, flashes during calibration |
| | | | In measuring mode: Main measured value |
| | | | In setup / calibr. mode: e.g. parameter |

5.2.2 Operating elements

The operating keys are located underneath the housing cover. The display and the alarm LED are visible through the viewing window. For operation, open the housing cover by removing the 4 screws.

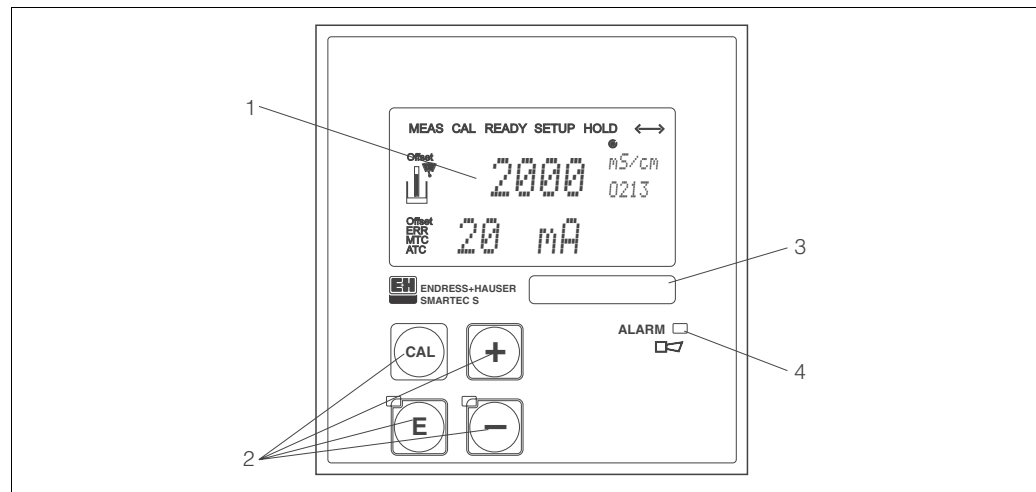





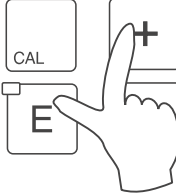
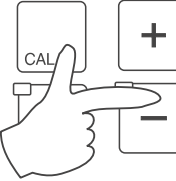

Fig. 25: Operating elements of Smartec S CLD132

- 1 Liquid crystal display showing measured values and configuration data
- 2 4 operating keys for calibration and instrument configuration
- 3 Field for user labeling
- 4 LED indicator for alarm function

5.2.3 Key assignment

	<p>CAL key</p> <p>When the CAL key is pressed, the instrument prompts for the calibration access code:</p> <ul style="list-style-type: none"> ■ Code 22 for calibration ■ Code 0 or any other number to view the calibration data <p>Use the CAL key to acknowledge calibration data and to continue through the calibration process.</p>
	<p>ENTER key</p> <p>When the ENTER key is pressed, the instrument prompts for the setup access code:</p> <ul style="list-style-type: none"> ■ Code 22 for setup and configuration ■ Code 0 or any other number to view the configuration data. <p>The ENTER key has several functions:</p> <ul style="list-style-type: none"> ■ It calls up the setup menus from the measuring mode ■ It is used to store (acknowledge) data entered in setup mode ■ It is used to move on within function groups

	<p>PLUS key and MINUS key In setup mode, the PLUS and MINUS keys have the following functions:</p> <ul style="list-style-type: none"> ■ Selection of function groups <p> Note! To select function groups in the order given in the chapter "Instrument configuration", use the MINUS key.</p> <ul style="list-style-type: none"> ■ Setting of parameters and numeric values <p>In measuring mode, repeatedly pressing the PLUS key displays the following settings in sequence:</p> <ol style="list-style-type: none"> 1. Temperature display in °F 2. Hide temperature display 3. Display of uncompensated conductivity value 4. Back to basic setting <p>In measuring mode, repeatedly pressing the MINUS key displays the following settings in sequence:</p> <ol style="list-style-type: none"> 1. Display of current measuring range 2. Display of current errors in sequence (max. 10) 3. After all errors are displayed, the standard display is shown again. In function group F, you can define an alarm for each error code.
	<p>Escape function Press the PLUS and MINUS keys simultaneously to return to the main menu. During calibration, this key combination goes directly to the end of calibration. When the PLUS and MINUS keys are pressed once more, the instrument returns to the measuring mode.</p>
	<p>Locking the keypad Pressing the PLUS and ENTER keys simultaneously for minimum 3s locks the keypad against unintentional entries. However, all settings can still be read. The code prompt displays the code 9999.</p>
	<p>Unlocking the keypad Pressing the CAL and MINUS keys simultaneously for minimum 3s unlocks the keypad. The code prompt displays the code 0.</p>

5.3 Local operation

5.3.1 Operating concept

Operating modes

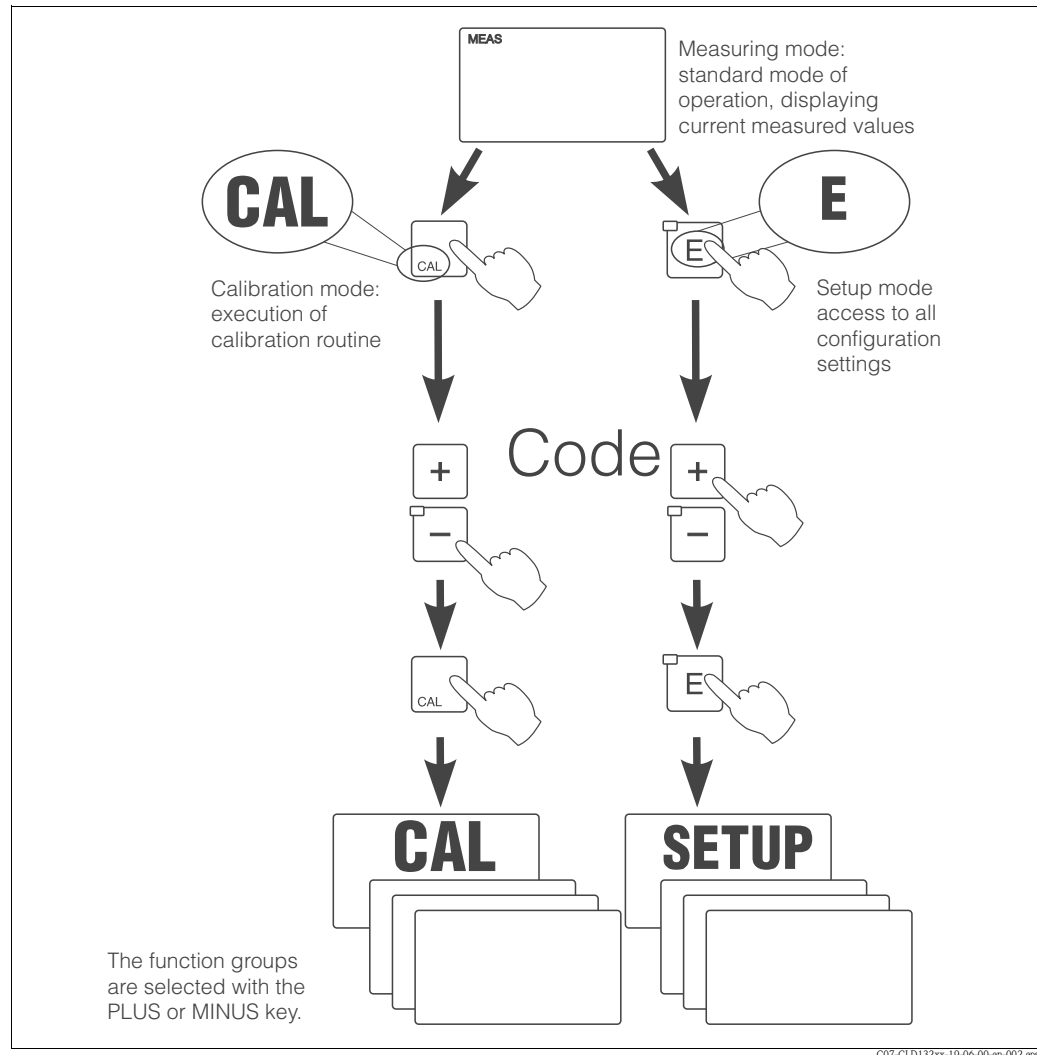

Fig. 26: Description of operating modes



Note!

If no key is pressed for 15 min. in setup mode, the instrument automatically switches back to the measuring mode. An active Hold function (Hold at Setup) is then reset.

Access codes

All instrument access codes are fixed, i.e. they cannot be modified. When the instrument requests the access codes, it recognises the difference between codes.

- **CAL key + Code 22:** access to calibration and offset menus.
- **ENTER key + Code 22:** access to the configuration menus, allowing configuration and user-specific settings.
- **PLUS + ENTER keys:** locks the keypad.
- **CAL + MINUS keys:** unlocks the keypad.
- **CAL or ENTER key + any code:** access to Read mode, i.e. all settings can be read but not changed.

Menu structure

The configuration and calibration functions are arranged in a menu structure by function groups. The function groups are selected in the setup mode with the PLUS and MINUS keys. The ENTER key is used to move from one function to the next within a function group. The PLUS and MINUS keys are used for option selection and editing. Selections must be confirmed by pressing the ENTER key. This also moves the cursor to the next function. Pressing the PLUS and MINUS keys at the same time terminates programming (return to main menu). When the PLUS and MINUS keys are pressed once more, the instrument returns to the measuring mode.



Note!

- If a change is made but not confirmed by pressing the ENTER key, the previous setting is retained.
- See the appendix of these operating instructions for an overview of the Smartec menu structure.

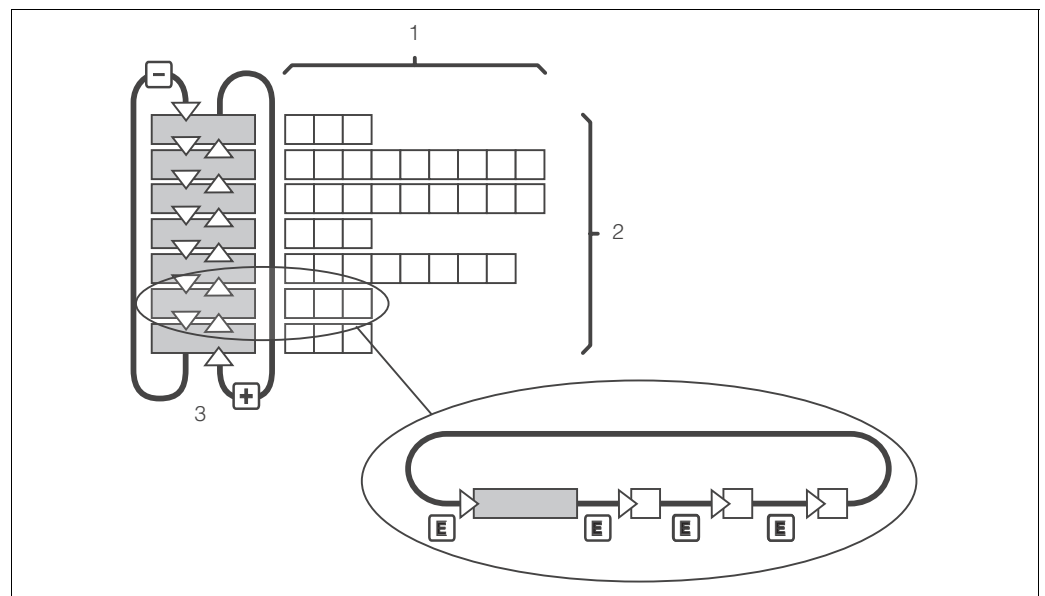

Fig. 27: Schematic of the Smartec menu structure

C07-CLD132xx-19-06-00-xx-010.eps

Hold function: "Freezing" the outputs

The current output can be "frozen" in the setup mode and during calibration, i.e. the last current value is constantly output. The display shows the "HOLD" message.



Note!

- Hold settings can be found in the chapters "Service" and "Remote parameter set switching (measuring range switching, MRS)".
- During "HOLD" in the measuring mode the contact will go to the normal position if it is configured as a limit contact.
- An active hold has priority over all other automatic functions.
- A possibly accumulated alarm delay is reset to "0".
- The hold function can also be activated externally via the hold input (see wiring diagram; binary input 1).
- The manual hold (field S5) remains active even after a power failure.

6 Commissioning

6.1 Function check



Warning!

- Check all connections for correctness.
- Make sure that the supply voltage is identical to the voltage written on the nameplate!

6.2 Start-up

Before first start-up, make sure you understand how to operate the transmitter. You should make particular reference to chapters 1 (Safety instructions) and 5 (Operation).

After power-up (connection to power), the instrument performs a self-test and then enters the measuring mode.

Calibrate the sensor as described in the chapter "Calibration".



Note!

During first start-up, calibration of the sensor is absolutely required to enable the measuring system to perform accurate measurement.

Configure the transmitter as described in the chapter "Quick setup". The values set by the user are kept even in the event of a power failure.

The following function groups are available on the Smartec S CLD132 (the function groups that are only available on the version equipped with the function extension are marked accordingly in the function descriptions):

Setup mode

- SETUP 1 (A)
- SETUP 2 (B)
- OUTPUT (O)
- ALARM (F)
- CHECK (P)
- RELAY (R)
- ALPHA TABLE (T)
- CONCENTRATION (K)
- SERVICE (S)
- E+H SERVICE (E)
- INTERFACE (I)
- TEMPERATURE COEFFICIENT (D)
- MRS (M)

Calibration mode

- CALIBRATION (C)

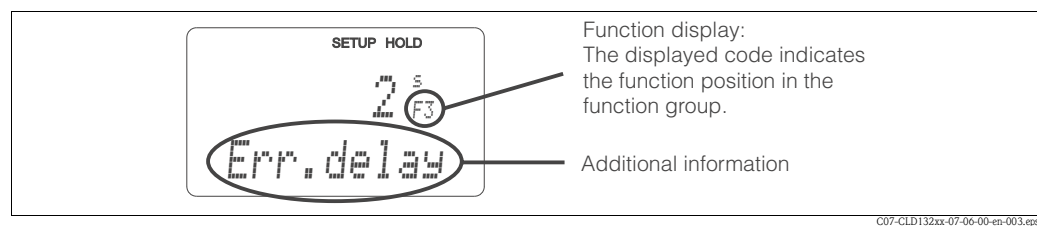

Fig. 28: Example for display in setup mode

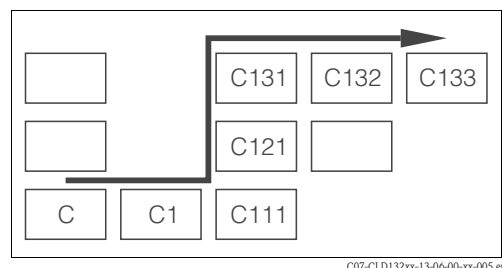

Fig. 29: Function coding

Selecting and locating functions is facilitated by a code displayed for each function in a special display field Fig. 28.

The structure of this coding is given in Fig. 29. The first column indicates the function group as a letter (see group designations). The functions in the individual groups are counted from the top to the bottom and from the left to the right.

For a detailed description of the function groups available on the Smartec S CLD132 see the chapter "Instrument configuration".

Factory settings

When the instrument is switched on for the first time, the factory settings are in effect. The following table provides an overview of all major settings. Please refer to the description of the individual functions in the chapter "Instrument configuration" for all other factory settings (the factory settings are printed in **bold** letters).

Function	Factory setting
Type of measurement	Inductive conductivity measurement, temperature measurement in °C
Temperature compensation type	Linear with reference temperature 25 °C / 77 °F
Temperature compensation	Automatic (ATC on)
Relay function	Alarm
Hold	Active during configuration and calibration
Measuring range	10 µS/cm ... 2000 mS/cm (measuring range set automatically)
Current outputs 1* and 2*	4 ... 20 mA
Current output 1: measured value for 4 mA signal current*	0 µS/cm
Current output 1: measured value for 20 mA signal current*	2000 mS/cm
Current output 2: measured value for 4 mA signal current*	0.0 °C / 32 °F
Current output 2: measured value for 20 mA signal current*	150.0 °C / 302 °F

* if equipped accordingly

Alarm contact

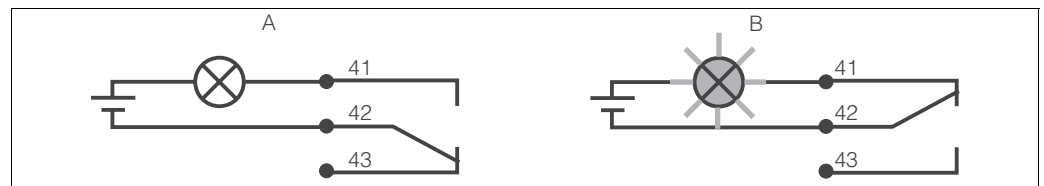

Fig. 30: Recommended fail-safe circuit for an alarm contact
 A Normal operating state
 B Alarm state

Normal operating state





- Instrument in operation
- No error message available (Alarm LED off)
- Relay picked up
- Contact 42/43 closed

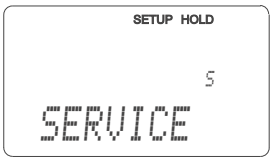
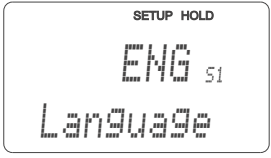
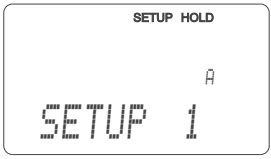
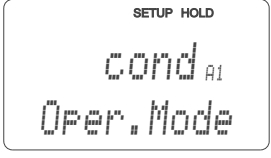

Alarm state

- Error message available (Alarm LED red) or
- Instrument defective or voltage-free (Alarm LED off)
- Relay dropped out
- Contact 41/42 closed

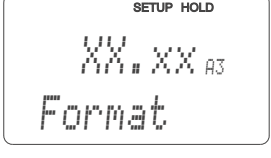
6.3 Quick setup

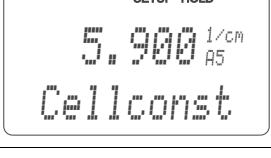
After switching the transmitter on, configure the major functions required for accurate measurement. The following section gives you an example for a basic configuration.

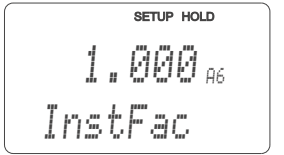
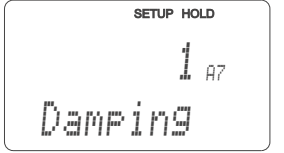
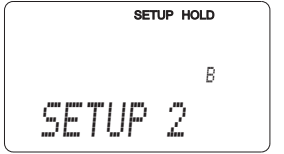
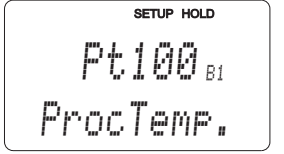
Input	Selection or range (factory setting bold)	Display
1. Press the ENTER key. 2. Enter the code 22 to be able to edit the setup. Press the ENTER key.		
3. Press the MINUS key several times until the "Service" function group is displayed. 4. Press the ENTER key to edit this function group.		 <p>SETUP HOLD 5 SERVICE</p>
5. Select your language, e.g. "ENG" for English. Confirm your entry by pressing the ENTER key.	ENG = English GER = German FRA = French ITA = Italian NEL = Dutch ESP = Spanish	 <p>SETUP HOLD ENG S1 Language</p>
6. Press the PLUS and MINUS keys simultaneously to quit the "Service" function group.		
7. Press the MINUS key several times until the "Setup 1" function group is displayed. 8. Press the ENTER key to edit "Setup 1".		 <p>SETUP HOLD A SETUP 1</p>
9. In A1, select the operating mode, e.g. "cond" = conductivity. Confirm your selection by pressing the ENTER key.	cond = conductivity conc = concentration	 <p>SETUP HOLD cond A1 Oper. Mode</p>
10. In A2, press the ENTER key to confirm the factory setting.	% ppm mg/l TDS = Total Dissolved Solids none	 <p>SETUP HOLD PPM A2 Conc. Unit</p>
11. In A3, press the ENTER key to confirm the factory setting.	XX.xx X.xxx XXX.x XXXX	 <p>SETUP HOLD XX.XX A3 Format</p>
12. In A4, press the ENTER key to confirm the factory setting.	auto , µS/cm, mS/cm, S/cm, µS/m, mS/m, S/m	 <p>SETUP HOLD auto A4 Unit</p>
13. In A5, enter the cell constant for the connected sensor. Refer to the sensor's or the compact version's quality certificate for the exact value.	0.10 ... 5.9 ... 9.99	 <p>SETUP HOLD 5.900 A5 Cellconst</p>

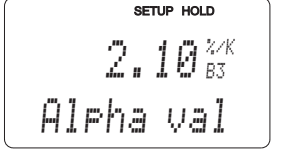
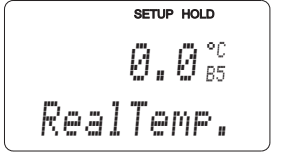
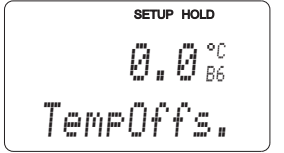
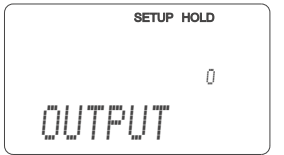
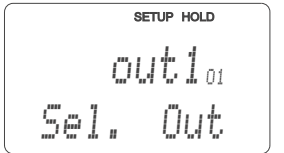
Input	Selection or range (factory setting bold)	Display
14. In A6, press the ENTER key to confirm the factory setting. If your wall distance is smaller than 15 mm / 0.59", refer to the chapters 3.3.1 and 6.4.14 for information on determining the installation factor.	0.10 ... 1 ... 5.00	
15. If you are working in applications that fluctuate a great deal and you need to stabilise the display, enter the required damping factor in A7. Confirm your entry by pressing ENTER. The display returns to the initial display of "Setup 1".	1 1 ... 60	
16. Press the MINUS key to go to the "Setup 2" function group. 17. Press the ENTER key to edit "Setup 2".		
18. In B1, select the temperature sensor of your conductivity sensor. By default, your measuring system is supplied with the CLS52 sensor with Pt 100 temperature sensor. Confirm your entry by pressing ENTER.	Pt100 Pt1k = Pt 1000 NTC30 fixed	
19. In B2, select the appropriate temperature compensation for your process, e.g. "lin" = linear. Confirm your selection by pressing ENTER. For detailed information on temperature compensation, see chapter 6.4.2.	none lin = linear NaCl = common salt (IEC 60746) Tab 1 ... 4	
20. In B3, enter the temperature coefficient α . Confirm your entry by pressing ENTER. For detailed information on determining the temperature coefficient, see chapters 6.4.2 or 6.4.12.	2.1 %/K 0.0 ... 20.0 %/K	
21. The real temperature is displayed in B5. If necessary, calibrate the temperature sensor to an external measurement. Confirm your entry by pressing ENTER.	Display and entry of real temperature -35.0 ... 250.0 °C	
22. The difference between the measured and the entered temperatures is displayed. Press the ENTER key. The display returns to the initial display of the "Setup 2" function group.	0.0 °C -5.0 ... 5.0 °C	
23. Press the MINUS key to go to the "Output" function group. 24. Press the ENTER key to edit the output settings.		
25. In O1, select your output, e.g. "out1" = output 1. Confirm your selection by pressing ENTER.	out 1 out 2	

Input	Selection or range (factory setting bold)	Display
26. In O2, select the linear characteristic. Confirm your selection by pressing ENTER.	lin = linear (1) sim = simulation (2)	<p>SETUP HOLD lin 02 Sel.Type</p>
27. In O211, select the current range for your output, e.g. 4 ... 20 mA. Confirm your selection by pressing ENTER.	4 ... 20 mA 0 ... 20 mA	<p>SETUP HOLD 4-20 0211 Sel.Range</p>
28. In O212, enter the conductivity corresponding to the minimum current value at the transmitter output, e.g. 0 µS/cm. Confirm your entry by pressing ENTER.	0.00 µS/cm 0.00 µS/cm ... 2000 mS/cm	<p>SETUP HOLD 0 µS/cm 0212 0/4 mA</p>
29. In O213, enter the conductivity corresponding to the maximum current value at the transmitter output, e.g. 930 mS/cm. Confirm your entry by pressing ENTER. The display returns to the initial display of the "Output" function group.	2000 mS/cm 0.0 µS/cm ... 2000 mS/cm	<p>SETUP HOLD 930 mS/cm 0213 20 mA</p>
30. Press the PLUS and MINUS keys simultaneously to return to measuring mode.		



Note!

You must perform an airset before installing the sensor. To do so, refer to the chapter "Calibration".

6.4 Instrument configuration

The following sections give a detailed description of all Smartec S CLD132 functions.

6.4.1 Setup 1 (conductivity, concentration)

In the SETUP 1 function group, you can change the operating mode and the sensor settings. You have already made all settings of this menu during the quick setup but you can modify the settings at any time.

Coding	Field	Selection or range (factory settings bold)	Display	Info
A	Function group SETUP 1			Basic settings.
A1	Select operating mode	cond = conductivity conc = concentration		Display varies depending on instrument version: – cond – conc Caution! Any change in operating mode causes an automatic reset of user settings.
A2	Select concentration unit to be displayed	% ppm mg/l TDS = Total Dissolved Solids none		
A3	Select display format for concentration unit	XX.xx X.xxx XXX.x XXXX		
A4	Select unit to be displayed for conductivity	auto , µS/cm, mS/cm, S/cm, µS/m, mS/m, S/m		When “auto” is selected, the maximum resolution possible is automatically selected.
A5	Enter cell constant for connected sensor	0.10 ... 5.9 ... 9.99		For the exact value of the cell constant, refer to the sensor’s or the compact version’s quality certificate.
A6	Installation factor	0.10 ... 1 ... 5.00		This is where the installation factor is edited. The correct factor is determined in C1(3), see chapter "Calibration" or referring to the installation factor diagram.
A7	Enter measured value damping	1 1 ... 60		Measured value damping causes averaging over the specified number of individual measured values. It is used, for example, to stabilise the display with applications that fluctuate a great deal. There is no damping if “1” is entered.

6.4.2 Setup 2 (temperature)

The temperature compensation only needs to be performed in the conductivity mode (selection in field A1).

The temperature coefficient specifies the change in conductivity per degree of temperature change. It depends on the chemical composition of the medium and the temperature itself.

In order to compensate for this dependence, three different compensation types can be selected in the Smartec S:

Linear temperature compensation

The change between two temperature points is considered to be constant, i.e. $\alpha = \text{const}$. The α value can be edited for the linear compensation type. The reference temperature is 25 °C / 77 °F.

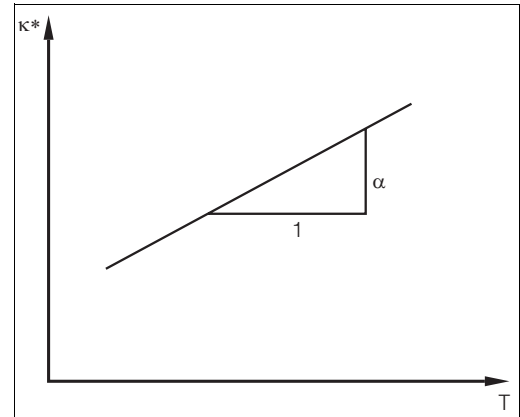

C07-CLD132xx-05-06-00-xx-009.eps

Fig. 31: Linear temperature compensation

* uncompensated conductivity

NaCl compensation

The NaCl compensation (according to IEC 60746) is based on a fixed nonlinear curve that defines the relationship between the temperature coefficient and the temperature. This curve is used for lower concentrations of up to approx. 5 % NaCl.

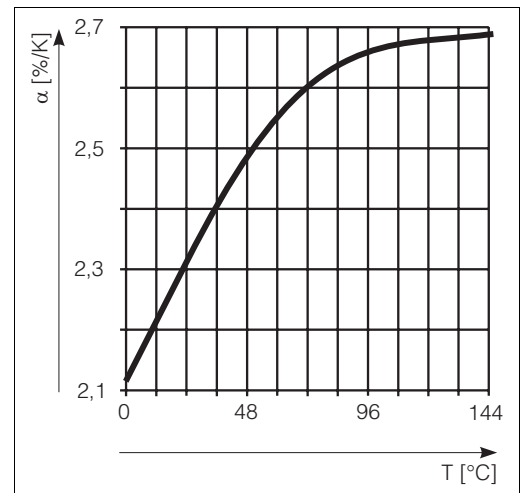

C07-CLD132xx-05-06-00-xx-010.eps

Fig. 32: NaCl compensation

Temperature compensation with table

When using the alpha table function for temperature compensation, the following conductivity data of the process medium to be measured are required:

Value pairs of temperature T and conductivity κ with:

- $\kappa(T_0)$ for the reference temperature T_0
- $\kappa(T)$ for temperatures which occur in the process

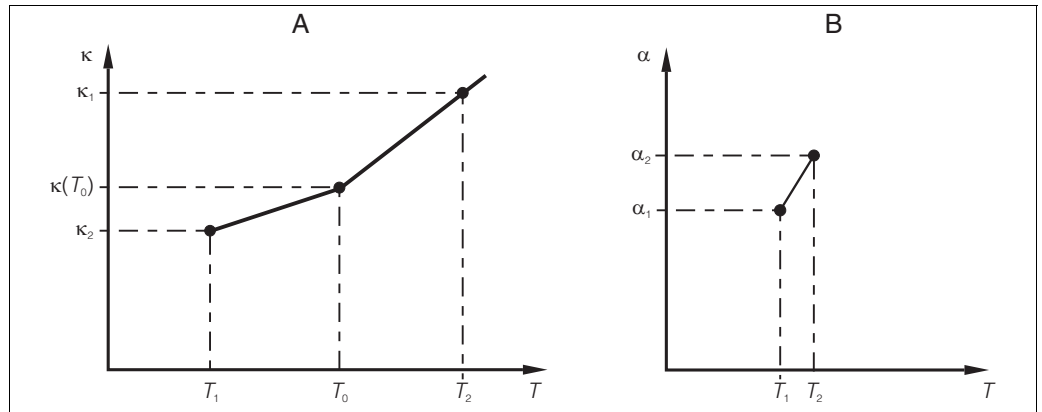

Fig. 33: Determination of temperature coefficient

- A Required data
- B Calculated α values

Use the following formula to calculate the α values for the temperatures occurring in your process:

$$\alpha = \frac{100}{\kappa(T_0)} \cdot \frac{\kappa(T) - \kappa(T_0)}{T - T_0}; T \neq T_0$$

Enter the α -T value pairs calculated with this formula in the fields T5 and T6 of the function group ALPA TABLE.

In the SETUP 2 function group, you can change the settings for temperature measurement. You have already made the settings of this function group during quick setup but you can modify the settings at any time.

Coding	Field	Selection or range (factory settings bold)	Display	Info
B	Function group SETUP 2		<div style="border: 1px solid black; padding: 5px; text-align: center;"> SETUP HOLD B SETUP 2 </div>	Settings for temperature measurement.
B1	Select temperature sensor	Pt100 Pt1k = Pt 1000 NTC30 fixed	<div style="border: 1px solid black; padding: 5px; text-align: center;"> SETUP HOLD Pt100_{B1} ProcTEMP. </div>	If set to "fixed": no temperature measurement, a fixed temperature value is entered instead.
B2	Select temperature compensation type	none lin = linear NaCl = common salt (IEC 60746) Tab 1 ... 4	<div style="border: 1px solid black; padding: 5px; text-align: center;"> SETUP HOLD lin_{B2} TempCOMP. </div>	This option is not displayed for concentration measurement. The options Tab 2 ... 4 are only available for transmitters with the "Remote measuring range switching" upgrade.
B3	Enter temperature coefficient α	2.1 %/K 0.0 ... 20.0 %/K	<div style="border: 1px solid black; padding: 5px; text-align: center;"> SETUP HOLD 2.10_{B3} %/K Alpha val </div>	Only if B2 = lin. Tables defined in B2 are not active in this case.

Coding	Field	Selection or range (factory settings bold)	Display	Info
B4	Enter process temperature	25 °C -10.0 ... 150.0 °C		Only if B1 = fixed. This value can only be specified in °C.
B5	Display temperature and calibrate temperature sensor	Display and entry of real temperature -35.0 ... 250.0 °C		This entry is used to calibrate the temperature sensor to an external measurement. Omitted if B1 = fixed.
B6	Temperature difference is displayed	0.0 °C -5.0 ... 5.0 °C		The difference between the entered actual value and the measured temperature is displayed. Omitted if B1 = fixed.

6.4.3 Current outputs

The OUTPUT function group is used to configure the individual outputs.

Furthermore, a current output value can be simulated to check the current outputs (O2 (2)).

Coding	Field	Selection or range (factory settings bold)	Display	Info
O	Function group OUTPUT			Configuration of the current output (not available for PROFIBUS versions).
O1	Select current output	out1 out2		A different characteristic can be selected for each output.
O2	O2 (1)	Enter linear characteristic lin = linear (1) sim = simulation (2)		The slope of the characteristic may be positive or negative.
	O211	Select current range 4 ... 20 mA 0 ... 20 mA		
	O212	0/4 mA value: enter corresponding measured value Cond: 0.00 µS/cm Conc: 0.00 % Temp.: -10.0 °C entire measuring range		Enter the measured value corresponding to the minimum current value (0/4 mA) at the transmitter output. Display format from A3. (Spreading: see Technical data.)

Coding		Field	Selection or range (factory settings bold)	Display	Info
	O213	20 mA value: enter corresponding measured value	Cond: 2000 mS/cm Conc: 99.99 % Temp.: 60.0 °C entire measuring range		Enter the measured value corresponding to the maximum current value (20 mA) at the transmitter output. Display format from A3. (Spreading: see Technical data.)
	O2 (2)	Current output simulation	lin = linear (1) sim = simulation (2)		The simulation is terminated by selecting (1).
	O221	Enter simulation value	current value 0.00 ... 22.00 mA		The current value entered here is output through the current output.

6.4.4 Alarm

The ALARM function group is used to define various alarms and to set output contacts.
Each individual error can be defined to be effective or not (at the contact or as an error current).

Coding		Field	Selection or range (factory settings bold)	Display	Info
F		Function group ALARM			Alarm function settings.
	F1	Select contact type	Stead = steady contact Fleet = fleeting contact		The contact type selected here only applies to the alarm contact.
	F2	Select time unit	s min		
	F3	Enter alarm delay	0 s (min) 0 ... 2000 s (min)		Depending on the unit selected in F2, the alarm delay is entered in s or min. The alarm delay does not affect the LED; it indicates the alarm immediately
	F4	Select error current	22 mA 2.4 mA		This selection must be made even if all error messages are suppressed in F5. Caution! If you selected the "0-20 mA" range in O211, you may not select the "2.4 mA" option here.

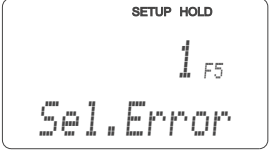
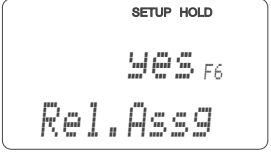
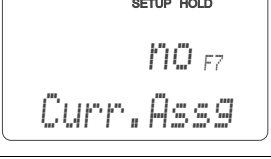
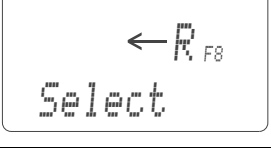
Coding	Field	Selection or range (factory settings bold)	Display	Info
F5	Select error	1 1 ... 255		Select the errors that are to trigger an alarm signal. The errors are selected via the error number. Please refer to the table in chapter 9.2 "System error messages" for the error numbers. The factory settings remain in effect for all errors not edited.
F6	Set alarm contact to be effective for selected error	yes no		If set to "no", all the other alarm settings (e.g. alarm delay) are also deactivated. The settings themselves are retained. This setting only applies to the error selected in F5. Factory setting is no starting with E080!
F7	Set error current to be effective for selected error	no yes		The error current selected in F4 becomes effective or is suppressed when an error occurs. This setting only applies to the error selected in F5.
F8	Return to menu or select next error	next = next error ←R		If next is selected, the software returns to F5. If ←R is selected, it returns to F.

6.4.5 Check

PCS alarm (Process Check System)

The PCS alarm is only available for transmitters with remote parameter set switching. This function is used to examine the measuring signal for deviations. If the measuring signal is constant for a specific period of time (several measured values), an alarm is issued. This type of sensor behaviour may be caused by soiling, etc.

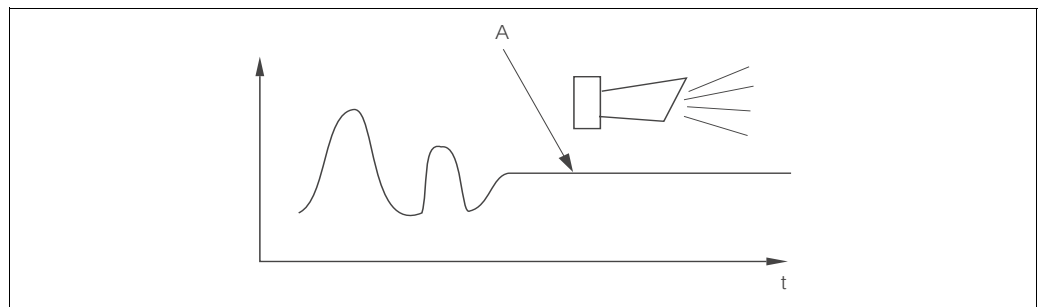

Fig. 34: PCS alarm (live check)

A Constant measuring signal = alarm is triggered after the configured PCS period



Note!

An active PCS alarm is automatically cleared when the measuring signal changes.

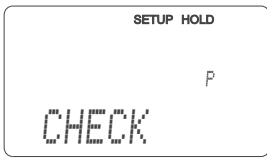
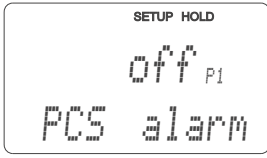
Coding	Field	Selection or range (factory settings bold)	Display	Info
P	Function group CHECK			Settings for sensor and process monitoring.
	P1 Set PCS alarm (live check)	off 1 h 2 h 4 h		This function is used to monitor the measuring signal. An alarm is triggered if it does not change for the period selected here. Monitoring limit: 0.3 % of mean value over selected period of time. (Error no.: E152)

6.4.6 Relay configuration

For Smartec S CLD132 equipped with remote parameter set switching (measuring range switching), there are three options for configuring the relay (selection in field R1):

- **Alarm**

The relay closes the contact 41/42 (voltage-free, safe state) if an alarm condition according to chapter 9.2 occurs and if the setting in the “Alarm contact” column is “yes”. You can change these settings as required (field F5 ff).

- **Limit**

The relay only closes the contact 42/43 if one of the defined limits is violated (value above or below limit, see Fig. 35) but not when an alarm condition is detected.

- **Alarm + Limit**

The relay closes the contact 41/42 if an alarm condition occurs. Limit violations only cause the relay to switch if error E067 is set to “yes” during relay assignment (field F6).

Please refer to Fig. 35 for a graphic representation of the contact states of the alarm contact.

- When the measured value increases (max function), the relay goes into alarm state (limit exceeded) at time t2 when the switch-on point has been exceeded (t1) and the pickup delay (t2 – t1) has expired.
- When the measured value decreases, the relay returns to normal operating state when the measured value drops below the switch-off point and after the dropout delay (t4 – t3).
- When the pickup and dropout delays are set to 0 s, the switch-on and switch-off points are identical to the contact switching points.

Settings for a minimum function can be made in the same way as for a maximum function.

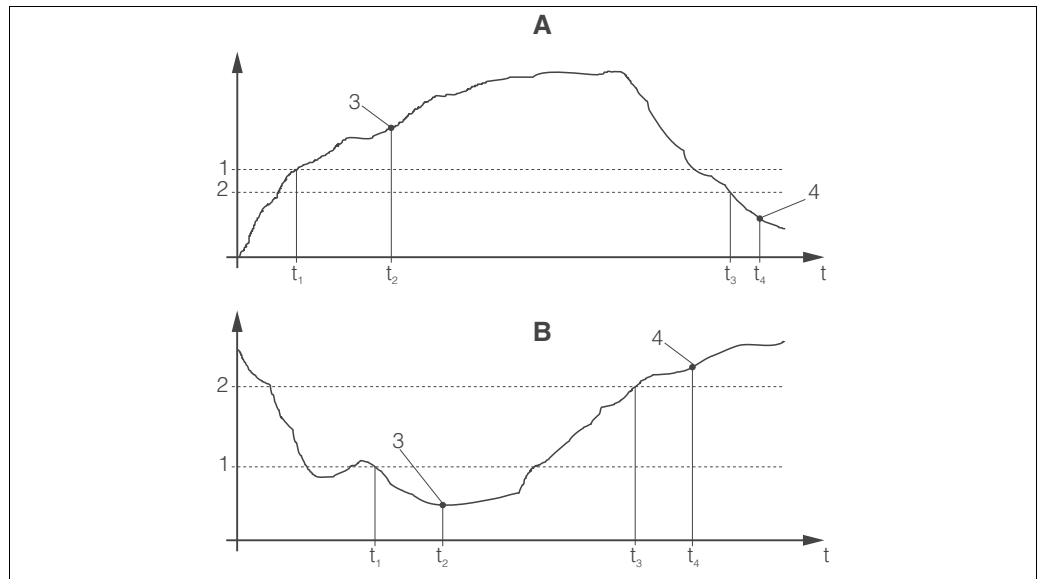

C07-CLD132xx-05-06-00-xx-008.eps

Fig. 35: Relation of switch-on and switch-off points and pickup and dropout delays
 A Switch-on point > switch-off point: Max. function
 B Switch-on point < switch-off point: Min. function

1 Switch-on point
 2 Switch-off point
 3 Contact ON
 4 Contact OFF

Coding	Field	Selection or range (factory settings bold)	Display	Info
R	Function group RELAY			Settings for relay contacts.
R1	Select function	alarm limit al+li = alarm + limit		When "alarm" is selected, the fields R2 ... R5 are irrelevant.
R2	Enter contact switch-on point	Cond: 2000 mS/cm Conc: 99.99 % entire measuring range		Only the operating mode selected in A1 appears. Note! Never set the switch-on point and the switch-off point to the same value.
R3	Enter contact switch-off point	Cond: 2000 mS/cm Conc: 99.99 % entire measuring range		The switch-off point entry selects a max contact (switch-off point < switch-on point) or a min contact (switch-off point > switch-on point), thereby implementing a hysteresis function (see Fig. 32).
R4	Enter pickup delay	0 s 0 ... 2000 s		

Coding	Field	Selection or range (factory settings bold)	Display	Info
R5	Enter dropout delay	0 s 0 ... 2000 s		
R6	Select simulation	auto manual		This selection can only be made if limit has been selected in R1.
R7	Switch relay on or off	on off		This selection can only be made if manual has been selected in R6. The relay can be switched on and off.

6.4.7 Temperature compensation with table

This function group is used to perform a temperature compensation with table (field B2 in SETUP 2 function group).

Enter the α -T value pairs in the fields T5 and T6.

Coding	Field	Selection or range (factory settings bold)	Display	Info
T	Function group ALPHA TABLE			Settings for temperature compensation.
T1	Select table	1 1 ... 4		Selection of table to be edited. Options 1 ... 4 are only available if the instrument is equipped with the remote measuring range switching.
T2	Select table option	read edit		
T3	Enter number of table value pairs	1 1 ... 10		Up to 10 value pairs can be entered in the α table. These are numbered from 1 ... 10 and can be edited individually or in sequence.
T4	Select table value pair	1 1 ... number of table value pairs assign		If "assign", go to T8.

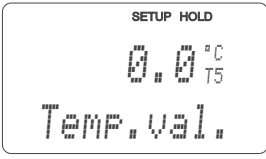
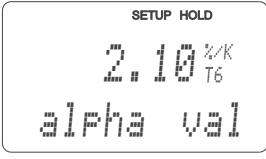
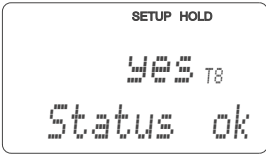
Coding	Field	Selection or range (factory settings bold)	Display	Info
T5	Enter temperature value	0.0 °C -10.0 ... 150.0 °C		The temperature values must have a minimum distance of 1 K. Factory setting for temperature value of value pairs in table: 0.0 °C; 10.0 °C; 20.0 °C; 30.0 °C ...
T6	Enter temperature coefficient α	2.10 %/K 0.00 ... 20.00 %/K		
T8	Enter whether or not the table status is ok	yes no		If "yes", return to T. If "no", return to T3.

6.4.8 Concentration measurement

The Smartec S CLD132 transmitter can convert conductivity values to concentration values. For this, set the operating mode to Concentration measurement (see field A1).

You must enter the basic data to which the concentration calculation should refer. For the most common substances, the required data is already saved in your device. You can select one of these substances in field K1.

If you want to specify the concentration of a sample, which is not saved in the device, you require the conductivity characteristics of the medium. To get the characteristics, you can either refer to the data sheets of the medium or determine the characteristics yourself.

1. To do so, create samples of the medium with the concentrations occurring in your process.
2. Measure the uncompensated conductivity of these samples at temperatures which likewise occur in your process. To get the uncompensated conductivity, press the PLUS key several times in measuring mode (see chapter "Key functions") or deactivate the temperature compensation (Setup 2, field B 2).
 - For variable process temperature:
If the variable process temperature should be taken into account for concentration measurement, you must measure the conductivity of each created sample at two different temperatures at least (ideally at the lowest and highest process temperature). The temperature values for the various samples must be identical. However, the difference between the temperatures must be at least 0.5 °C.
At least two differently concentrated samples measured at two different temperatures are required because the transmitter needs a minimum of four references.
 - For constant process temperature:
Measure the differently concentrated samples at this constant process temperature.
A minimum of two samples is necessary.

Finally, you should have measuring data which are similar to those shown in the following figures:

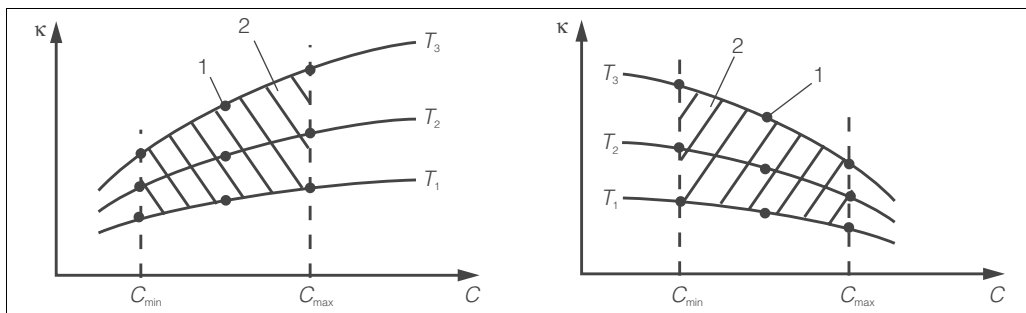

Fig. 36: Measured data for variable process temperatures (example)

κ Conductivity
 C Concentration
 T Temperature
 1 Measuring point
 2 Measuring range

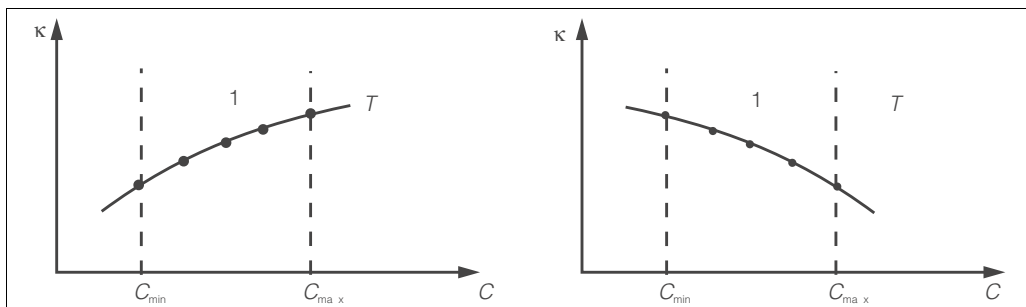

Fig. 37: Measured data for a constant process temperature (example)

κ Conductivity
 C Concentration
 T Constant temperature
 1 Measuring range

The characteristics received from the measuring points must be strictly monotonously increasing or strictly monotonously decreasing in the range of the process conditions. Therefore, neither maxima / minima nor ranges with a constant behaviour can occur. Curve profiles such as those in Fig. 38 are not permitted.

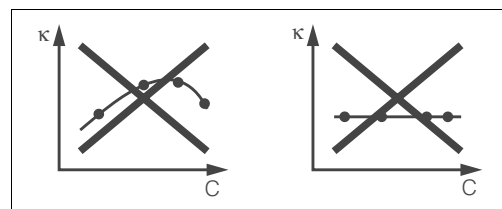

Fig. 38: Impermissible curve profiles

κ Conductivity
 C Concentration

Value entry

Enter the three characteristic values for each measured sample in the fields K6 to K8 (value triplets of conductivity, temperature and concentration).

- Variable process temperature:
 Enter at least four value triplets.
- Constant process temperature:
 Enter at least two value triplets.



Note!

- Please make sure that the concentrations and temperatures measured for your samples correspond to the measuring range of the process. If the measured values of the process are outside the range of your sample values, this considerably reduces the level of accuracy and the error messages E078 or E079 will be displayed.
 If you enter an additional value triplet of 0 μS/cm and 0 % for each temperature used, you can work from the start of measuring range with sufficient accuracy and without an error message.
- In case of concentration measurement, temperature compensation is automatically performed using the entered table values. Therefore, the temperature coefficient set in the SETUP 2 function group is not active.

- Enter the values in the order of increasing concentration (see the following example).



mS/cm	%	°C
240	96	60
380	96	90
220	97	60
340	97	90
120	99	60
200	99	90

Coding	Field	Selection or range (factory settings bold)	Display	Info
K	Function group CONCENTRATION			Settings for concentration measurement. Four fixed and four editable concentration fields are stored in this function group.
K1	Select concentration curve to be used to calculate the display value	NaOH 0... 15 % H ₂ SO ₄ 0 ... 30 % H ₃ PO ₄ 0 ... 15 % HNO ₃ 0 ... 25 % Tab 1 ... 4		The user tables 2 ... 4 can only be selected if the instrument is equipped with the remote measuring range switching.
K2	Select correction factor	1 0.5 ... 1.5		If required, select a correction factor (only available for the user tables).
K3	Select table to be edited	1 1 ... 4		When editing a curve, another curve should be used to calculate the current display values (see K1). Selections 2 ... 4 are only available with the remote measuring range switching.
K4	Select table option	read edit		This selection applies to all concentration curves.
K5	Enter number of reference triplets	4 1 ... 16		Each triplet consists of three numeric values.
K6	Select triplet	1 1 ... number of triplets in K4 assign		Any triplet can be edited. If "assign", go to K10.

Coding	Field	Selection or range (factory settings bold)	Display	Info
K7	Enter uncompensated conductivity	0.0 mS/cm 0.0 ... 9999 mS/cm		
K8	Enter concentration value for K6	0.00 % 0.00 ... 99.99 %		
K9	Enter temperature value for K6	0.0 °C -35.0 ... 250.0 °C		
K10	Enter whether or not the table status is ok	yes no		Back to K.

6.4.9 Service

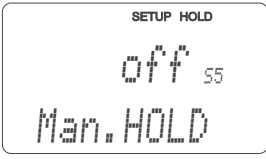
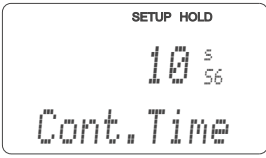
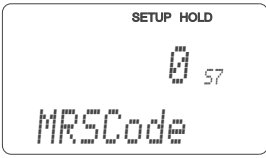
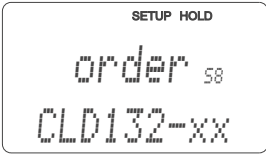
Coding	Field	Selection or range (factory settings bold)	Display	Info
S	Function group SERVICE			Settings for service functions.
S1	Select language	ENG = English GER = German FRA = French ITA = Italian NEL = Dutch ESP = Spanish		This field must be configured once during start-up. Then you can exit S1 and continue.
S2	HOLD effect	froz. = last value fix = fixed value		froz.: Display of last value before activation of hold. fix: When hold is active, the fixed value entered in S3 is displayed.
S3	Enter fixed value	0 0 ... 100 % (of current output value)		Only available if S2 = fixed value.
S4	Hold configuration	S+C = setup and calibration CAL = calibration Setup = setup none = no hold		S = setup C = calibration

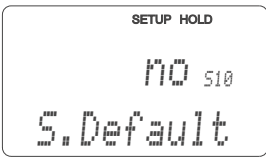
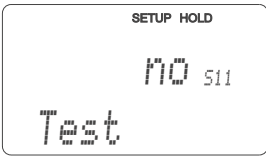
Coding	Field	Selection or range (factory settings bold)	Display	Info
S5	Manual hold	On Off		
S6	Enter hold dwell period	10 s 0 ... 999 s		
S7	Enter SW upgrade release code of function extension MRS	0 0 ... 9999		Entering an incorrect code returns you to the measurement menu. The number is edited with the PLUS or MINUS key and confirmed with the ENTER key.
S8	Order number is displayed			The order code is not automatically changed to reflect an upgrade.
S9	Serial number is displayed			
S10	Reset of instrument (restore default values) 	no Sens = sensor data Facyt = factory settings		Facyt= All data are cleared and reset to the factory settings! Sens = Sensor data are cleared (temp. offset, Airset value, cell constant, installation factor, ser.no.)
S11	Perform instrument test	no Displ = display test		

6.4.10 E+H Service

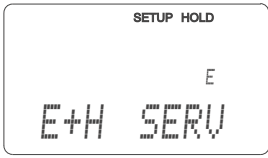
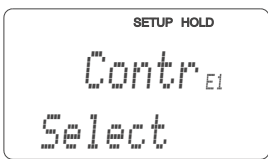
Coding	Field	Selection or range (factory settings bold)	Display	Info
E	Function group E+H SERVICE			E+H service settings.
E1	Select module	Contr = controller (1) Trans = transmitter (2) MainB = mainboard (3) Sens = sensor (4)		



Coding		Field	Selection or range (factory settings bold)	Display	Info
	E111 E121 E131 E141	Software version is displayed			E111: Version of transmitter software E121-141: Version of module firmware (if available)
	E112 E122 E132 E142	Hardware version is displayed			Cannot be edited.
	E113 E123 E133 E143	Serial number is displayed			Cannot be edited.
	E145 E146 E147 E148	Enter and confirm serial number			

6.4.11 Interfaces

Coding		Field	Selection or range (factory settings bold)	Display	Info
I		Function group INTERFACE			Communication settings (HART or PROFIBUS transmitter versions only).
	I1	Enter address	Address HART: 0 ... 15 or PROFIBUS: 0 ... 126		
	I2	Tag description			

6.4.12 Determining the temperature coefficient

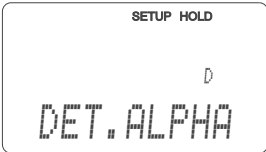
Determining the temperature coefficient by the following method is only possible for instruments equipped with remote parameter set switching (see "Product structure"). Standard instruments (basic versions) can be retrofitted with remote parameter set switching (see chapter "Accessories").

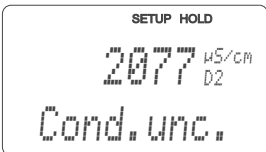
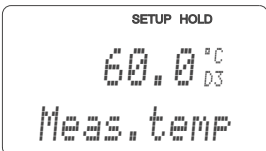
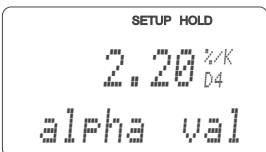
Coding	Field	Selection or range (factory settings bold)	Display	Info
D	Function group TEMPERATURE COEFFICIENT			Settings for temperature coefficient. Calculator function: calculates the α value from the compensated conductivity + uncompensated conductivity + temperature value.
D1	Enter compensated conductivity	current value 0 ... 9999		Displays the current compensated conductivity. If necessary, change this value to the desired value (determined by a comparison measurement for example).
D2	Display of uncompensated conductivity	current value 0 ... 9999		Current value of uncompensated conductivity, cannot be edited.
D3	Enter current temperature	current value -35.0 ... 250.0 °C		
D4	Display of determined α value			Used in B3 for example. You must enter the value manually.

6.4.13 Remote parameter set switching (measuring range switching, MRS)

You can order the remote parameter set switching via binary inputs directly as an option of your Smartec S CLD132 (see "Product structure") or you can retrofit a standard transmitter with the MRS function extension (see the chapter "Accessories").

The remote parameter set switching function permits complete parameter sets to be entered for up to 4 substances.

Individual settings for each parameter set:

- Operating mode (conductivity or concentration)
- Temperature compensation
- Current output (main parameter and temperature)
- Concentration table
- Limit relay

Assignment of binary inputs

The Smartec S CLD132 transmitter has 2 binary inputs. They can be defined in field M1 as follows:





Assignment of field M1	Assignment of binary inputs
M1 = 0	MRS not active. The binary input 1 can be used for external hold.
M1 = 1	The binary input 2 can be used to switch between 2 measuring ranges (parameter sets). The binary input 1 can be used for external hold.
M1 = 2	The binary inputs 1 and 2 can be used to switch between 4 measuring ranges (parameter sets). This is the setting used in the following example.

Settings of the 4 parameter sets

Example: CIP cleaning

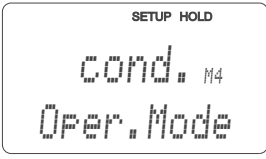
Binary input 1		0	0	1	1
Binary input 2		0	1	0	1
	Parameter set	1	2	3	4
Coding / software field	Medium	Beer	Water	Alkaline solution	Acid
M4	Operating mode	Conductivity	Conductivity	Concentration	Concentration
M8, M9	Current output	1 ... 3 mS/cm	0.1 ... 0.8 mS/cm	0.5 ... 5%	0.5 ... 1.5 %
M6	Temp. comp.	User Tab. 1	linear	-	-
M5	Conc. tab.	-	-	NaOH	User Tab.
M10, M11	Limits	on: 2.3 mS/cm off: 2.5 mS/cm	on: 0.7 µS/cm off: 0.8 µS/cm	on: 2 % off: 2.1 %	on: 1.3 % off: 1.4 %

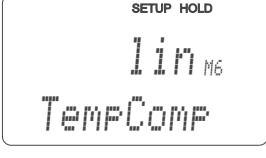
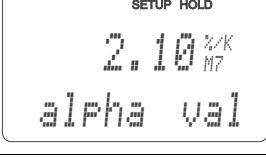
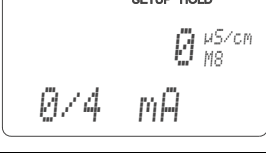
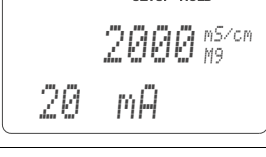
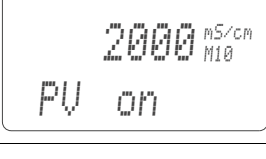
Coding	Field	Selection or range (factory settings bold)	Display	Info
M	Function group MRS			Settings of remote parameter set switching (measuring range switching). M1 + M2: apply to measuring mode. M3 ... M11: apply to configuration of parameter sets.
M1	Select binary inputs	1 0, 1, 2		0 = no MRS 1 = 2 parameter sets selectable via binary input 2. Binary input 1 for hold. 2 = 4 parameter sets selectable via binary inputs 1+2.
M2	Displays active parameter set or, if M1 = 0, select active parameter set	1 1 ... 4 if M1 = 0		If M1 = 0, selectable. If M1 = 1 or 2, display depending on binary inputs.
M3	Select parameter set to be configured in M4 ... M8	1 1 ... 4 if M1=0 1 ... 2 if M1=1 1 ... 4 if M1=2		Selection of parameter set to be configured (the active parameter set is selected in M2 or with the binary inputs).

Coding	Field	Selection or range (factory settings bold)	Display	Info
M4	Select operating mode	cond = conductivity conc = concentration		The operating mode can be individually defined for each parameter set.
M5	Select medium	NaOH , H2SO4, H3PO4, HNO3 Tab 1 ... 4		Only available if M4 = conc.
M6	Select temperature compensation	none, lin , NaCl, Tab 1 ... 4 if M4 = cond		Only available if M4 = cond.
M7	Enter α value	2.10 %/K 0 ... 20 %/K		Can only be entered if M6 = lin.
M8	Enter measured value for 0/4 mA value	Cond.: 0 ... 2000 mS/cm Conc.: Unit: A2, format: A3		
M9	Enter measured value for 20 mA value	Cond.: 0 ... 2000 mS/cm Conc.: Unit: A2, format: A3		
M10	Enter switch-on point for limit	Cond.: 0 ... 2000 mS/cm Conc.: Unit: A2, format: A3		
M11	Enter switch-off point for limit	Cond.: 0 ... 2000 mS/cm Conc.: Unit: A2, format: A3		The switch-off point entry selects a max contact (switch-off point < switch-on point) or a min contact (switch-off point > switch-on point), thereby implementing an always required hysteresis function. Never set the switch-off point and the switch-on point to the same value.



Note!

If remote parameter set switching is selected, the parameter sets that have been entered are processed internally but the fields A1, B1, B3, R2, K1, O212, O213 show the values of the first measuring range.

6.4.14 Calibration

To access the "Calibration" function group, press the CAL key.

This function group is used to calibrate the transmitter. Two different types of calibration are possible:



- Calibration by measurement in a calibration solution of a known conductivity.
- Calibration by entering the exact cell constant of the conductivity sensor.



Note!

- At first start-up, sensor calibration is **absolutely** required in order for the measuring system to be able to generate accurate measuring values.
- If the calibration procedure is aborted by pressing the PLUS and MINUS keys at the same time (return to C114, C126 or C136) or if the calibration is faulty, then the previous calibration data are reinstated. A calibration error is indicated by the "ERR" message and flashing of the sensor symbol on the display. Repeat calibration!
- The instrument is automatically switched to hold during calibration (factory setting).

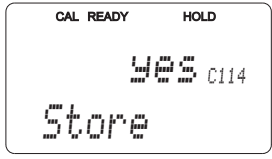
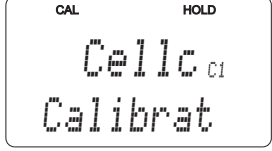
Coding	Field	Selection or range (factory settings bold)	Display	Info
C	Function group CALIBRATION			Calibration settings.
C1 (1)	Compensation of residual coupling	Airs = Airset (1) Cellc = cell constant (2) InstF = installation factor (3)		The calibration of the sensor is to be performed in air. The sensor must be dry.
Remove sensor from the medium and dry completely .				
C111	Residual coupling start calibration (airset)	current measured value		Start calibration with CAL.
C112	Residual coupling is displayed (airset)	-80.0 ... 80.0 μ S		Residual coupling of measuring system (sensor and transmitter).
C113	Calibration status is displayed	o.k. E xxx		If the calibration status is not o.k., the second display line shows an explanation of the error.

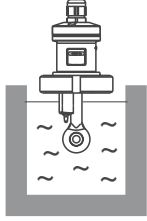
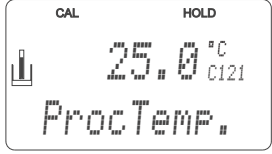
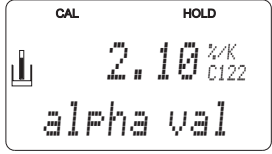
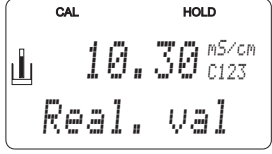
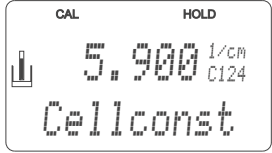
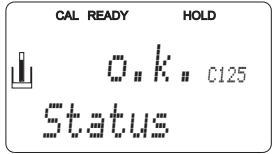
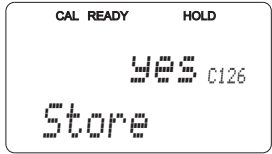
Coding		Field	Selection or range (factory settings bold)	Display	Info
	C114	Store calibration results?	yes no new		If C113 = E xxx, then only no or new . If new, return to C. If yes/no, return to "Measurement".
	C1 (2)	Calibration of cell constant	Airs = Airset (1) Cellc = cell constant (2) InstF = installation factor (3)		
Immerse sensor in calibration solution.  Note! This section describes the calibration for temperature compensated conductivity. For calibration with uncompensated conductivity, set the temperature coefficient α to 0.					The sensor should be immersed at a sufficient distance from the vessel wall (installation factor has no influence if $a > 15 \text{ mm} / 0.59"$).
	C121	Enter process temperature (MTC)	25 °C -35.0 ... 250.0 °C		Only exists if B1 = fixed.
	C122	Enter α value of calibration solution	2.10 %/K 0.00 ... 20.00 %/K		This value is specified in the Technical Information of all E+H calibration solutions. You can also use the printed-on table to calculate the value. Set α to 0 for calibration with uncompensated values.
	C123	Enter correct conductivity value of calibration solution	current measured value 0.0 ... 9999 mS/cm		The display is always in mS/cm.
	C124	Calculated cell constant is displayed	0.1 ... 5.9 ... 9.99 cm^{-1}		The calculated cell constant is displayed and entered in A5.
	C125	Calibration status is displayed	o.k. E xxx		If the calibration status is not o.k., the second display line shows an explanation of the error.
	C126	Store calibration results?	yes no new		If C125 = E xxx, then only no or new . If new, return to C. If yes/no, return to "Measurement".

Coding		Field	Selection or range (factory settings bold)	Display	Info
	C1 (3)	Calibration with sensor adaptation for inductive sensors	Airs = Airset (1) Cellc = cell constant (2) InstF = installation factor (3)		Sensor calibration with compensation of wall influence. The distance from the sensor to the pipe wall and the pipe material (conductive or nonconductive) influence the measured value. The installation factor compensates this influence. See chapter "Installation conditions".
The sensor is installed in the process.					
	C131	Enter process temperature (MTC)	25 °C -35.0 ... 250.0 °C		Only exists if B1 = fixed.
	C132	Enter α value of the calibration solution	2.10 %/K 0.00 ... 20.00 %/K		This value is specified in the Technical Information of all E+H calibration solutions. You can also use the printed-on table to calculate the value. Set α to 0 for calibration with uncompensated values.
	C133	Enter correct conductivity value of the medium	current measured value 0.0 ... 9999 mS/cm		Determine the correct conductivity value by a reference measurement.
	C134	Calculated installation factor is displayed	1 0.10 ... 5.00		The distance of the sensor to the pipe wall and the pipe material (conductive or nonconductive) influence the measured value. The installation factor compensates this influence. See chapter "Installation conditions".
	C135	Calibration status is displayed	o.k. E xxx		If the calibration status is not o.k., the second display line shows an explanation of the error.
	C136	Store calibration results?	yes no new		If C135 = E xxx, then only no or new . If new, return to C. If yes/no, return to "Measurement".

6.5 Communication interfaces

Please refer to separate operating instructions BA 212C/07/en (HART) or BA 213C/07/en (PROFIBUS) for transmitters equipped with a communication interface.

7 Maintenance

Take all necessary measures in due time to guarantee the safety of operation and reliability of the entire measuring system.

Maintenance on the Smartec S CLD132 includes:

- Calibration (see chapter "Calibration")
- Cleaning of assembly and sensor
- Checking of cables and connections.



Warning!

- Please be aware of effects work performed on the instrument might have on the process control system or the process itself.
- When removing the sensor during maintenance or calibration, please consider potential hazards due to pressure, high temperatures and contamination.
- Disconnect the instrument from the power source before opening it up.
Work with live lines may only be performed by trained electricians!
- Switched contacts may be supplied from separate circuits. These circuits must also be de-energised before work on the terminals is performed.



Caution ESD!

- Electronic components are sensitive to electrostatic discharges. Personal protective measures, such as discharge via PE or permanent grounding using a wrist strap, are to be taken.
- For your own safety, use only original spare parts. Original parts will guarantee functionality, accuracy and reliability after repairs.



Note!

Please contact your Endress+Hauser representative if you have any questions. You can also send your queries to the Endress+Hauser Service Organisation via the Internet: **www.endress.com**

7.1 Maintenance of Smartec S CLD132

7.1.1 Dismantling Smartec S CLD132



Caution!

Consider potential effects on process when removing the instrument from service!



Note!

For item numbers see the exploded view drawing in chapter 9.5.

1. Remove the cover (item 40).
2. Remove the internal protecting cover (item 140). Release the lateral latches with a screwdriver.
3. Pull off the five-pole terminal block first to de-energise the instrument.
4. Then pull off the remaining terminal blocks. Now you can dismantle the instrument.
5. Loosen 4 screws to remove the complete electronics box from the steel housing.
6. The power supply module is snapped in and can be loosened and removed by slightly bending the electronics box walls. Start with the rear catches!
7. Pull off the ribbon cable connected (item 110); now the power supply can be removed.
8. The central module is also snapped in and easy to remove. Note! The central module may be fastened with an additional centre screw. Remove this screw if present.

7.1.2 Special case: replacement of central module



Note!

A replacement central module LSCx-x is supplied from the factory with the instrument serial number of the new module. Since the serial and release numbers are linked to enable the extended functions and parameter set switching, an existing extension / MRS cannot be active. All the editable data are reset to the factory settings following central module replacement.

Proceed as described below when replacing the central module:

1. If possible, record the user settings of the instrument, e.g.:
 - Calibration data
 - Conductivity and temperature current assignment
 - Relay function selections
 - Limit settings
 - Alarm settings, alarm current assignment
 - Monitoring functions
 - Interface parameters
 2. Dismantle the instrument as described in the chapter "Dismantling Smartec S CLD132".
 3. Refer to the part number of the central module to determine whether the new module has the same part number as the old one.
 4. Assemble the instrument with the new module.
 5. Start up the instrument and test its basic functions (e.g. measured value and temperature display, operation via keyboard).
 6. Enter the instrument serial number:
 - Read the instrument serial number ("ser-no.") on the nameplate.
 - Enter this number in the fields E115 (year, one-digit), E116 (month, one-digit), E117 (sequence number, four-digit).
 - Field E118 displays the complete number for verification; confirm with ENTER or abort and re-enter.
-  **Caution!**
 The serial number can only be entered – and **only once** – in the case of a new module from the factory with a new module number! Make sure that your entry is correct before confirming with ENTER!
 Entry of an incorrect code will prevent the extended functions from being enabled. An incorrect serial number can only be corrected at the factory.
7. Enter the release code in field Feld S7 (see nameplate "/Codes:").
 8. Verify that the functions have been enabled:
 Extension functions e.g. by accessing function group CHECK / code P, PCS function must be available; Measuring range switching e.g. by calling up the alpha tables (function group T / 1 ... 4 must be selectable in T1).
 9. Restore the user settings of the instrument.

7.2 Maintenance of measuring system

7.2.1 Cleaning conductivity sensors

Inductive sensors are less sensitive to soiling than conventional conductive sensors since there is no galvanic contact with the medium.

However, dirt may collect in the measuring opening (making it narrower), which changes the cell constant. In this case, an inductive sensor also requires cleaning.

Recommended cleaning procedure:

- Oily and greasy coatings:
Clean with detergent (fat solvent, e.g. alcohol, acetone, poss. detergent).



Warning!

Protect your hands, eyes and clothes when using the cleaning agents described below!

- Limestone deposits or metal hydroxide coatings:
Loosen coatings with diluted hydrochloric acid (3 %), brush off carefully if necessary and rinse thoroughly with plenty of clear water.
- Coatings containing sulphide (from FGD or sewage treatment plants):
Use mixture of hydrochloric acid (3 %) and thiourea (commercially available), brush off carefully if necessary and rinse thoroughly with plenty of clear water.
- Coatings containing protein (food industry):
Use mixture of hydrochloric acid (0.5 %) and pepsin (commercially available), brush off carefully if necessary and rinse thoroughly with plenty of clear water.

7.2.2 Checking inductive conductivity sensors

The following specifications apply to the CLS52 sensor.

The sensor lines on the instrument or junction box are to be disconnected for all tests described here!

- Testing transmitting and receiving coils
 - Ohmic resistance approx. 0.5 ... 2 Ω .
 - Inductivity approx. 180 ... 360 mH (at 2 kHz; serial connection as equivalent circuit diagram)
 Separate version: measure the white and red coaxial cables.
 Compact version: measure the white and brown coaxial cables.
 (Between the inner conductor and screen in both cases.)
- Testing the coil shunt
 - A shunt between the two sensor coils is not allowed. The resistance measured should be >20 M Ω .
 Test with ohmmeter between brown or red coaxial cable and white coaxial cable.
- Testing the temperature sensor

Use the table in chapter "Instrument check by medium simulation" to check the Pt100 in the sensor.

 Measure between the green and white wires in the case of the separate version and between green and yellow. The resistance values should be identical.
 Compact version: measure between the two red wires.
- Testing the temperature sensor shunt
 - Shunts between the temperature sensor and the coils are not allowed. Check with ohmmeter for >20 M Ω .
 Measure between the temperature sensor wires (green + white + yellow or red + red) and the coils (red and white coaxial cables or brown and white coaxial cables).

7.2.3 Instrument check by medium simulation

The inductive sensor cannot be simulated.

However, the overall system comprising the CLD132 and inductive sensor can be checked using equivalent resistances. Note the cell constant ($k_{\text{nominal}} = 5.9$ for CLS52).

For an accurate simulation, the actual cell constant (can be read in field C124) is to be used to calculate the display value:

Display conductivity_[mS/cm] = $k \cdot 1/R_{[k\Omega]}$. Values for simulation with CLS52 at 25 °C / 77 °F:

Simulation resistance R	Default cell constant k	Conductivity display
5.9 Ω	5.90 cm ⁻¹	1000 mS/cm
10 Ω	5.90 cm ⁻¹	590 mS/cm
29.5 Ω	5.90 cm ⁻¹	200 mS/cm
100 Ω	5.90 cm ⁻¹	59 mS/cm
295 Ω	5.90 cm ⁻¹	20 mS/cm
2.95 kΩ	5.90 cm ⁻¹	2 mS/cm
29.5 kΩ	5.90 cm ⁻¹	200 μS/cm

Conductivity simulation:

Pull a cable through the sensor opening and then connect, e.g. to a decade resistor.

Temperature sensor simulation:

The temperature sensor of the inductive sensor is connected to terminals 11, 12 and 13 on the instrument (compact version and separate version).

For simulation, the temperature sensor is disconnected, and an equivalent resistance is connected instead. This resistance must also be connected using a three-wire arrangement, i.e. connection to terminals 11 and 12, with a bridge from 12 to 13.

The table shows some resistance values for temperature simulation:

Temperature	Resistance
-20 °C	92.13 Ω
-10 °C	96.07 Ω
0 °C	100.00 Ω
10 °C	103.90 Ω
20 °C	107.79 Ω
25 °C	109.73 Ω
50 °C	119.40 Ω
80 °C	130.89 Ω
100 °C	138.50 Ω
150 °C	157.32 Ω
200 °C	175.84 Ω

7.2.4 Checking line extension and junction box

- Use the methods described in chapters "Checking inductive conductivity sensors" and "Instrument check by medium simulation" to perform a quick functional check from the conductivity sensor to the measuring instrument via an extension.
- Checking the extension cable type:
 - The inductive sensor only works reliably with the original CLK5 cable!
- Check junction boxes for moisture (possible influence in low conductivity range):
 - Dry junction box
 - Replace cover gasket
 - Inspect cable glands for tightness
 - Use desiccant bag
- Check junction boxes for correct line connections:
 - When the prescribed original CLK5 cable is used, the cable wires (colours) are connected 1:1.
- Check junction boxes for correct outer screen connections:
 - Immunity to interference is only guaranteed if the screens are connected!
- Check junction boxes for tightness of clamping screws and examine for corrosion:
 - Tighten screws some time after start-up
 - Replace terminals if corroded; make sure that the junction box is tight.

7.3 Service equipment "Optoscope"

The Optoscope together with the "Scopeware" software offers the following possibilities, without having to remove or open the transmitter and without galvanic connection to the instrument:

- Documentation of the instrument settings in conjunction with Commuwin II
- Software update by the service technician
- Upload/download a hex dump to duplicate configurations.

The optoscope serves as an interface between the transmitter and PC / laptop. The information exchange takes place via the optical interface on the transmitter and via an RS 232 interface on the PC / laptop (see "Accessories").

8 Accessories

8.1 Sensors

Indumax H CLS52

Inductive conductivity sensor with fast response time and hygienic design; with integrated temperature sensor.

Order according to product structure, see Technical Information TI 167C/07/en. One Indumax H CLS52 is included in the Smartec S CLD132 scope of delivery.

8.2 Extension cable

Extension cable CLK5

for inductive conductivity sensors, for extension via the VBM junction box, sold by the metre; order no.: 50085473

8.3 Junction box

Junction box VBM

for extension of measuring cable connection between sensor and instrument, material cast aluminium, ingress protection 65; order no.: 50003987

 Note!

The desiccant bag must be checked and replaced at regular intervals which depend on ambient conditions in order to prevent inaccurate measurement due to moisture bridges in the measuring line.

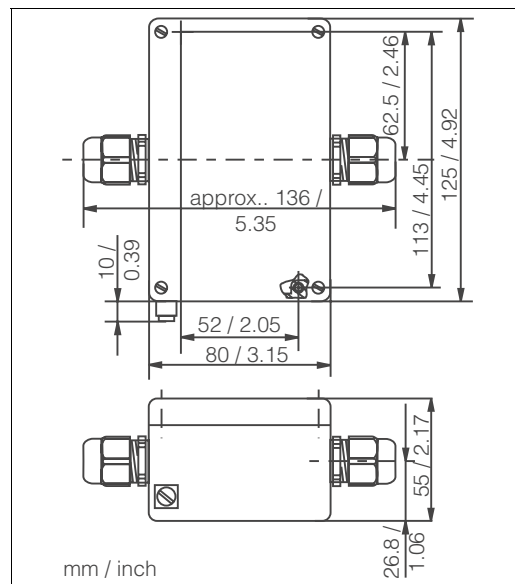

Fig. 39: Dimensions of VBM junction box

Desiccant bag with colour indicator for VBM junction box; order no. 50000671

8.4 Post mounting kit

- Mounting kit for installation of Smartec S CLD132 on horizontal or vertical pipes and posts (max. \varnothing 60 mm / 2.36"), material stainless steel 1.4301; order no.: 50062121

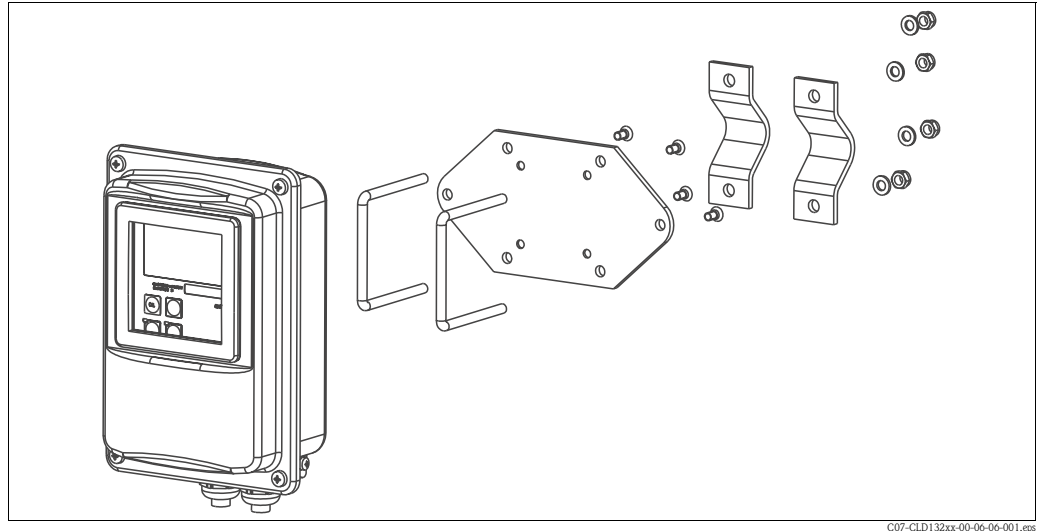

Fig. 40: Mounting kit for installing CLD132 separate version on posts or pipes

8.5 Software upgrade

- Software upgrade
 - Remote parameter set switching (measuring range switching, MRS) and determination of temperature coefficient;
 - order no.: 51501643
 - Serial number of instrument must be specified with order.

8.6 Calibration solutions

Precision solutions, traceable to SRM (standard reference material) by NIST, for qualified calibration of conductivity measurement systems according to ISO 9000, with temperature table

- CLY11-B
 - 149.6 μ S/cm (reference temperature 25 °C / 77 °F), 500 ml / 0.13 US.gal.
 - Order no. 50081903
- CLY11-C
 - 1.406 mS/cm (reference temperature 25 °C / 77 °F), 500 ml / 0.13 US.gal.
 - Order no. 50081904
- CLY11-D
 - 12.64 mS/cm (reference temperature 25 °C / 77 °F), 500 ml / 0.13 US.gal.
 - Order no. 50081905
- CLY11-E
 - 107.0 mS/cm (reference temperature 25 °C / 77 °F), 500 ml / 0.13 US.gal
 - Order no. 50081906

8.7 Optoscope

- Optoscope
 - Interface between transmitter and PC / laptop for service purposes.
 - The Windows software "Scopeware" required for the PC or laptop is supplied with the Optoscope.
 - The Optoscope is supplied in a sturdy plastic case with all the accessories required.
 - Order no. 51500650

9 Troubleshooting

9.1 Troubleshooting instructions

The transmitter continually monitors its own functions. If the instrument detects a defect, the error number appears on the display. This error number is displayed underneath the main value unit display. If several errors are detected, these can be called up with the MINUS key. Refer to the table "System error messages" for error numbers and the appropriate corrective measures.

In case of malfunctions or errors without error messages, use the tables "Process-specific errors" and "Instrument-specific errors" to locate and eliminate the error. The "Instrument-specific errors," table also specifies required spare parts.

9.2 System error messages

The system error messages can be called up and selected with the MINUS key.

Error no.	Display	Tests and / or measures	Alarm contact		Error current	
			Factory	User	Factory	User
E001	EEPROM memory error	1. Switch instrument off and back on.	yes		no	
E002	Instrument not calibrated, calibration data invalid, no user data or user data invalid (EEPROM error), software does not match hardware (central module)	2. Set to factory settings (S11).	yes		no	
		3. Load hardware-compatible software (with Optoscope, see chapter "Service equipment Optoscope").				
		4. If problem persists, return instrument to your local Endress+Hauser sales agency for repair or replace instrument.				
E003	Download error	Download must not access locked functions (e.g. temperature table in basic version).	yes		no	
E007	Transmitter malfunction, software does not match transmitter version		yes		no	
E008	Sensor or sensor connection faulty	Check sensor and sensor connection (see chapter "Instrument check by medium simulation" or call the E+H Service).	yes		no	
E010	No temperature sensor connected or temperature sensor short-circuited (temperature sensor faulty)	Check temperature sensor and connections; if necessary, check instrument with temperature simulator.	yes		no	
E025	Limit for Airset offset exceeded	Repeat Airset (in air) or replace sensor. Clean and dry sensor before Airset.	yes		no	
E036	Sensor calibration range exceeded	Clean and recalibrate sensor; if necessary, check sensor and connections.	yes		no	
E037	Below calibration range of sensor		yes		no	
E045	Calibration aborted	Recalibrate.	yes		no	
E049	Calibration range of installation factor exceeded	Check pipe diameter, clean sensor and repeat calibration.	yes		no	
E050	Below calibration range of installation factor		yes		no	
E055	Below measuring range of main parameter	Immerse sensor in conductive medium or perform Airset.	yes		no	
E057	Measuring range of main parameter exceeded	Check measurement, control and connections (simulation see chapter "Instrument check by medium simulation").	yes		no	
E059	Below temperature measuring range		yes		no	
E061	Temperature measuring range exceeded		yes		no	

Error no.	Display	Tests and / or measures	Alarm contact		Error current	
			Factory	User	Factory	User
E063	Below current output range 1	Check measured value and current output assignment (function group O).	yes		no	
E064	Current output range 1 exceeded		yes		no	
E065	Below current output range 2	Check measured value and current output assignment.	yes		no	
E066	Current output range 2 exceeded		yes		no	
E067	Limit contactor set value exceeded	Check measured value, limit setting and metering devices. Only available with R1 = alarm + limit value or limit value.	yes		no	
E077	Temperature outside α value table range	Check measurement and tables.	yes		no	
E078	Temperature outside concentration table		yes		no	
E079	Conductivity outside concentration table		yes		no	
E080	Current output 1 parameter range too small	Spread current output.	no		no	
E081	Current output 2 parameter range too small	Spread current output.	no		no	
E100	Current simulation active		no		no	
E101	Service function yes	Switch service function off or switch instrument off and back on.	no		no	
E102	Manual mode active		no		no	
E106	Download yes	Wait for download to end.	no		no	
E116	Download error	Repeat download.	no		no	
E150	Distance between temperature values in α value table too small	Enter correct values in α value table (minimum distance of 1 K required between temperature values).	no		no	
E152	Live Check alarm	Check sensor and connection.	no		no	

9.3 Process-specific errors

Use the following table to locate and correct errors.

Error	Possible cause	Tests and / or remedial measures	Equipment, spare parts, personnel
Display deviates from reference measurement	Calibration faulty	Calibrate instrument according to chapter "Calibration".	Calibration solution or sensor certificate
	Sensor soiled	Clean sensor.	See chapter "Cleaning conductivity sensors".
	Incorrect temperature measurement	Check temperature value on instrument and reference unit.	Temperature measuring instrument, precision thermometer
	Incorrect temperature compensation	Check compensation method (none / ATC / MTC) and compensation type (linear/substance/user table).	Please note: transmitter has separate calibration and operating temperature coefficients.
	Reference instrument calibration faulty	Calibrate reference instrument or use calibrated instrument.	Calibration solution, operating instructions of reference instrument
	Incorrect ATC setting on reference instrument	Compensation method and compensation type must be identical on both instruments.	Operating instructions of reference instrument

Error	Possible cause	Tests and / or remedial measures	Equipment, spare parts, personnel
Implausible measured values in general: – continuous measured value overflow – measured value always 000 – measured value too low – measured value too high – measured value frozen – incorrect current output value	Short circuit / moisture in sensor	Check sensor.	See chapter "Checking inductive conductivity sensors".
	Short circuit in cable or junction box	Check cable and junction box.	See chapter "Checking extension cable and junction box".
	Interruption in sensor	Check sensor.	See chapter "Checking inductive conductivity sensors".
	Interruption in cable or junction box	Check cable and junction box.	See chapter "Checking extension cable and junction box".
	Incorrect cell constant setting	Check cell constant.	Sensor nameplate or certificate
	Incorrect output assignment	Check assignments of measured value to current signal.	
	Incorrect output function	Check 0-20 / 4 -20 mA selection and curve shape (linear / table).	
	Air cushion in assembly	Check assembly and installation.	
	Incorrect temperature measurement / temperature sensor defective	Check instrument with equivalent resistance/ check Pt100 in sensor.	Pt100 simulation: s. chapter "Instrument check by medium simulation". Pt100 test: s. chapter "Checking inductive conductivity sensors".
	Transmitter module defective	Test with new module.	See chapters "Instrument-specific errors" and "Spare parts".
	Impermissible instrument operating state (no response to key actuation)	Switch instrument off and back on.	EMC problem: check grounding and line routing if problem persists or call Endress+Hauser Service to test.
Incorrect temperature value	Incorrect sensor connection	Verify connections using connection diagram; three-wire connection mandatory.	Connection diagram in chapter "Electrical connection"
	Measuring cable defective	Check cable for interruption/short circuit/shunt.	Ohmmeter; also see chapter "Instrument check by medium simulation".
	Incorrect temperature sensor type	Select temperature sensor type on instrument (field B1).	
Incorrect conductivity measured value in process	No / incorrect temperature compensation	ATC: select compensation type; linear: set correct coefficient. MTC: set process temperature.	
	Incorrect temperature measurement	Check temperature value.	Reference instrument, thermometer
	Bubbles in medium	Suppress bubble formation: – gas bubble trap – counterpressure (cover) – bypass measurement	
	Incorrect sensor orientation	Centre hole in sensor must point in medium flow direction.	Compact version: Remove electronics box to turn sensor (s. chapter "Sensor positioning"). Separate version: turn sensor in flange.
	Flow rate too high (may cause bubbles)	Reduce flow or choose low turbulence mounting position.	
	Interference current in medium	Ground medium close to sensor; remove/repair interference source.	Most frequent cause of currents in medium: defective submerged motors
	Sensor soiled or coated	Clean sensor (see chapter "Cleaning conductivity sensors").	Heavily soiled media: use spray cleaning.
Measured value fluctuates	Measuring cable interferences	Connect cable screen according to connection diagram.	See chapter "Electrical connection".
	Signal output line interferences	Check line routing, try separate line routing.	Separate routing of signal output and measuring input lines
	Interference currents in medium	Eliminate source of interference or ground medium close to sensor.	

Error	Possible cause	Tests and / or remedial measures	Equipment, spare parts, personnel
Limit contact does not work	Relay configured for alarm	Activate limit contactor.	See field R1.
	Pickup delay setting too long	Shorten pickup delay.	See field R4.
	"Hold" function active	"Automatic Hold" during calibration, "Hold" input activated; "Hold" via keyboard active.	See fields S2 to S5.
Limit contact works continuously	Dropout delay setting too long	Shorten dropout delay.	See field R5.
	Control loop interruption	Check measured value, current output, actuators, chemical supply.	
No conductivity current output signal	Line open or short-circuited	Disconnect line and measure directly on instrument.	mA meter 0–20 mA
	Output defective	See chapter "Instrument-specific errors".	
Fixed conductivity current output signal	Current simulation active	Switch off simulation.	See field O22.
	Impermissible operating state of processor system	Switch instrument off and back on.	EMC problem: check installation, screen, grounding if problem persists/ call Endress+Hauser Service to test.
Incorrect current output signal	Incorrect current assignment	Check current assignment: 0–20 mA or 4–20 mA?	Field O21 1
	Total load in current loop excessive (> 500 Ω.)	Disconnect output and measure directly on instrument.	mA meter for 0–20 mA DC
	EMC (interference coupling)	Disconnect both output lines and measure directly on instrument.	Use shielded lines, ground screens on both sides, route line in other duct if necessary.
No temperature output signal	Instrument does not have 2nd current output	Refer to nameplate for variant; change LSCH-x1 module if necessary.	Module LSCH-x2, see chapter "Spare parts".
	Instrument with PROFIBUS PA	PA instrument has no current output!	
Extension package functions not available (Live Check, current curve 2 ... 4, alpha value curve 2 ... 4, user conc. curve 1 ... 4)	Extension package not enabled (enable with code that depends on serial number and is received from Endress+Hauser with order of extension package)	<ul style="list-style-type: none"> – When upgrading instrument with extension package: code received from Endress+Hauser ⇒ enter. – After replacing defective LSCH/LSCP module: first enter instrument serial number (s. nameplate) manually, then enter code. 	For a detailed description, see chapter "Replacement of central module".
No HART communication	No central HART module	Verify by looking at nameplate: HART = -xxx5xx and -xxx6xx	Upgrade to LSCH-H1 / -H2.
	Current output < 4 mA	For further information see BA 212C/07/en, "Field communication with HART".	
	No or wrong DD (device description)		
	HART interface missing		
	Instrument not registered with HART server		
	Load too low (load > 230 Ω required)		
	HART receiver (e.g. FXA 191) not connected via load but via power supply		
	Incorrect device address (addr. = 0 for single operation, addr. > 0 for multi-drop operation)		
	Line capacitance too high		
	Line interferences		
Several devices set to same address	Set addresses correctly.	Communication not possible with several devices set to same address.	

Error	Possible cause	Tests and / or remedial measures	Equipment, spare parts, personnel
No PROFIBUS® communication	No central PA/DP module	Verify by looking at nameplate: PA = -xxx3xx /DP = xxx4xx	Upgrade to LSCP module, see chapter "Spare parts".
	Incorrect instrument software version (without PROFIBUS)	For further information, see BA 213C/07/en "Field communication with PROFIBUS PA/DP".	
	Commuwin (CW) II: Incompatible CW II and instrument software versions		
	No or incorrect DD/DLL		
	Incorrect baud rate setting for segment coupler in DPV-1 server		
	Incorrect station (master) addressed or duplicate address		
	Incorrect station (slaves) address		
	Bus line not terminated		
	Line problems (too long, cross section too small; not shielded, screen not grounded, wires not twisted)		
	Bus voltage too low (bus supply voltage typ. 24 V DC for non-Ex)		

9.4 Instrument-specific errors

The table below will help you diagnose problems and specifies the spare parts required.

A diagnosis depending on difficulty and measuring equipment at hand is to be performed by:

- trained operator personnel
- operator's electricians
- company responsible for system installation / operation
- E+H-Service

Please refer to the chapter "Spare parts" for information on the exact designations of the spare parts and their installation.

Error	Possible cause	Tests and / or remedial measures	Equipment, spare parts, personnel
Display dark, no LEDs active	No mains voltage	Check if mains voltage is available.	Electrician / e.g. multimeter
	Wrong supply voltage / voltage too low	Compare mains voltage and rating on nameplate.	Operator (utility company specification or multimeter)
	Connection fault	Terminal not tightened;; insulation clamped in terminal; wrong terminals used.	Electrician
	Fuse blown	Compare mains voltage and rating on nameplate and replace fuse.	Electrician / correct fuse; see drawing in chapter "Spare parts".
	Power supply unit defective	Replace power supply unit using correct variant.	On-site diagnosis by Endress+Hauser Service (test module required)
	Central module LSCH / LSCP defective	Replace central module using correct variant.	On-site diagnosis by E+H Service (test module required)
	Ribbon cable between central module and power supply unit loose or defective	Check ribbon cable, replace if necessary.	See chapter "Spare parts".
Display dark, LED active	Central module defective (module: LSCH/LSCP)	Replace central module.	On-site diagnosis by E+H Service (test module required)

Error	Possible cause	Tests and / or remedial measures	Equipment, spare parts, personnel
Display shows measured value but – value does not change and / or – instrument cannot be operated	Ribbon cable or transmitter module not properly installed	Reinsert transmitter module, use additional fastening screw M3 if necessary. Check if ribbon cable inserted correctly.	Refer to exploded view in chapter "Spare parts".
	Impermissible operating system state	Switch instrument off and back on.	Possible EMC problem: if problem persists, check the installation or call E+H Service to have it checked.
Incorrect display, missing dots, segments, characters or lines	Moisture or dirt in display frame, rubber not pressed on correctly or PCB contacts soiled	Replace central module LSC.... Emergency: Remove display frame, clean glass and PCB, dry well and reinstall. Do not touch conducting rubber with hands!	See chapter "Spare parts".
Instrument gets hot	Incorrect voltage / too high	Compare mains voltage and rating on nameplate.	Operator, electrician
	Heating from process or solar radiation	Improve positioning or use separate version. Use sun protection outdoors.	
	Power supply unit defective	Replace power supply unit.	Can only be diagnosed by E+H Service.
Incorrect measured conductivity and / or temperature value	Transmitter module defective (module: MKIC), please perform tests and take measures according to chapter "Process errors without messages"	Test measuring inputs: – Simulation with resistance, see table in chpt. "Instrument check by medium simulation" – Connect 100 Ω resistor to terminals 11 / 12 + 13 = display 0 °C	Test negative: replace module (using correct variant). Refer to exploded view in chapter "Spare parts".
Incorrect current output signal	Not calibrated correctly	Test with built-in current simulation (field O221), connecting mA meter directly to current output.	If simulation value is incorrect: recalibration at factory or new LSCxx module are required. If simulation value is correct: check current loop for load and shunts.
	Load excessive		
	Shunt / short-circuit to frame in current loop		
	Incorrect mode of operation	Check whether 0–20 mA or 4–20 mA has been selected.	
No current output signal	Current output stage defective (LSCH/LSCP module)	Test with built-in current simulation, connecting mA meter directly to current output.	If test fails: Replace central module LSCH/LSCP (using correct variant).
Additional functions (extended functions or measuring range switching) missing	No or wrong release codes used	If upgraded: Check whether correct serial number was used when ordering extension functions or MRS.	To be handled by E+H Sales.
	Incorrect instrument serial number stored in LSCH/LSCP module	Check whether serial number on nameplate matches SNR in LSCH/ LSCP (field S 10).	Instrument serial no. in LSCH/LSCP module is required for the function extensions.
Additional (extended functions or measuring range switching) not available after replacement of LSCH/LSCP module	LSCH or LSCP replacement modules are supplied with the instrument serial no. 0000. Extensions are not released ex-factory.	For LSCH / LSCP with serial no. 0000, an instrument serial no. can be entered once in fields E115 to E118. Then enter release code for extension package.	For a detailed description, see chapter "Replacement of central module".
No HART or PROFIBUS PA/DP interface function	Wrong central module	HART: LSCH-H1 or -H2 module, PROFIBUS PA: LSCP-PA module, PROFIBUS DP: LSCP-DP module, see fields E111 ... 113.	Replace central module; operator or E+H-Service.
	Wrong instrument software	SW version, see field E111.	SW can be changed with Optoscope.
	Incorrect configuration	See troubleshooting table in chapter "System errors without messages".	

9.5 Spare parts

Spare parts are to be ordered from your sales centre responsible. Specify the order numbers listed in the chapter "Spare parts kits".

To be on the safe side, you should **always** specify the following data with your spare part orders:

- Instrument order code (order code)
- Serial number (serial no.)
- Software version where available

Refer to the nameplate for the order code and serial number.

The software version is displayed in the instrument software (see chapter "Instrument configuration") if the instrument processor system is functional.

9.5.1 Exploded view

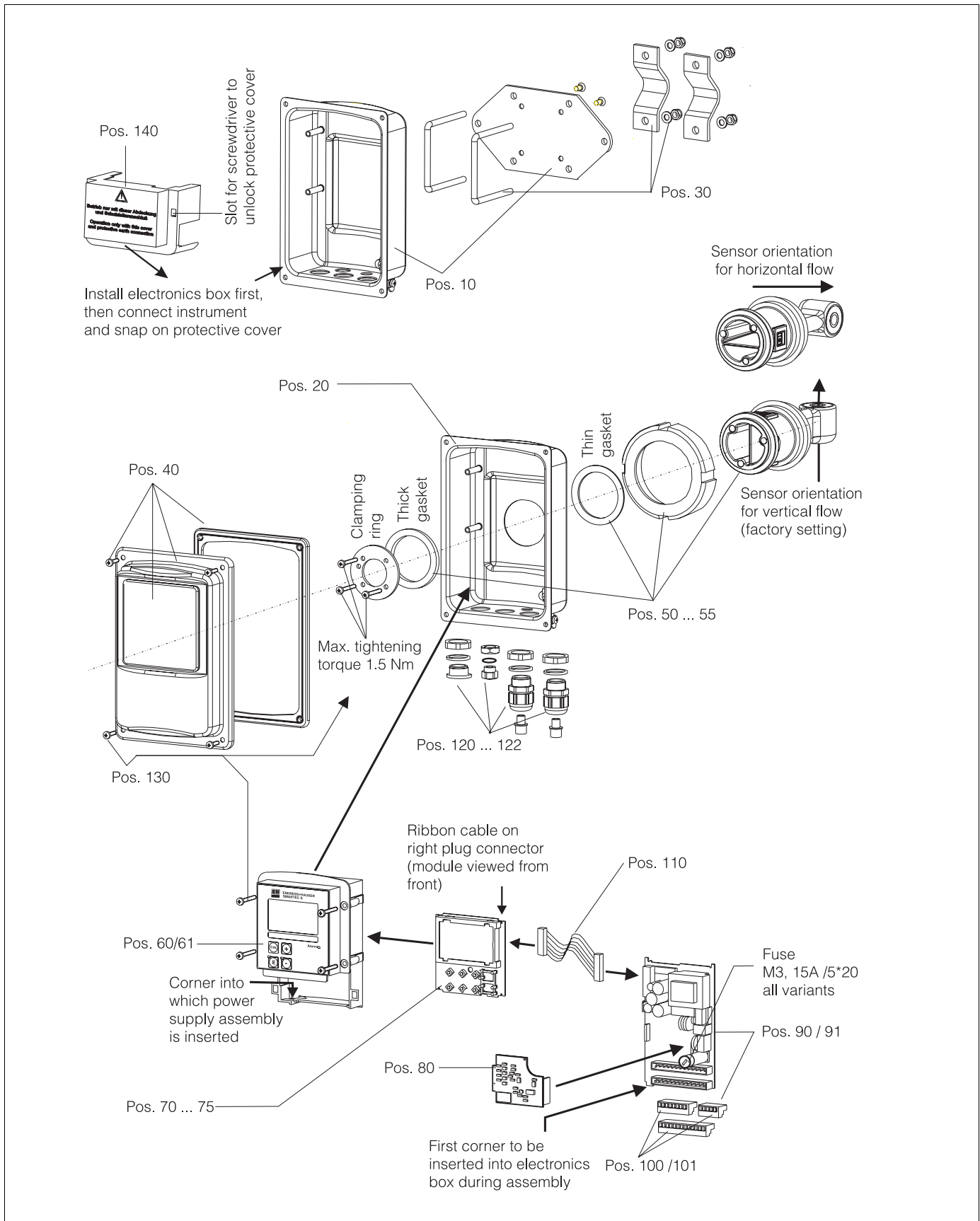

The exploded view drawing shows all components and spare parts of Smartec S CLD132. Use the position numbers to find the spare parts designation and their order number in the following section.

9.5.2 Spare part kits

Item	Kit designation	Name	Function/content	Order number
10	Housing bottom, separate		Bottom assembly	51501574
20	Housing bottom, compact		Bottom assembly	51501576
30	Post mounting kit		1 pair of post mounting parts	50062121
40	Housing cover		Cover with accessories	51501577
50	Sensor assembly APV, fast temperature measurement		Sensor, gaskets	51501578
51	Sensor assembly Clamp 2", fast temperature measurement		Sensor, gaskets	51501579
52	Sensor assembly G 1.5, fast temperature measurement		Sensor with bellows, gaskets	51501580
53	Sensor assembly dairy fitting, fast temperature measurement		Sensor with union nut	51501581
54	Sensor assembly Varivent, fast temperature measurement		Sensor, gaskets	51501582
55	Sensor assembly SMS 2", fast temperature measurement		Sensor, gaskets	51502279
50	Replacement sensor APV, encapsulated Pt 100		Sensor, gaskets	51517171
51	Replacement sensor Clamp 2", encapsulated Pt 100		Sensor, gaskets	51517166
52	Replacement sensor G 1.5, encapsulated Pt 100		Sensor with bellows, gaskets	51517168
53	Replacement sensor dairy fitting, encapsulated Pt 100		Sensor with union nut	51517167
54	Replacement sensor Varivent, encapsulated Pt 100		Sensor, gaskets	51517170
55	Replacement sensor SMS 2", encapsulated Pt 100		Sensor, gaskets	51517169
60	Elektronics box		Box w. membrane, key tappets	51501584
61	Electronics box PA/DP		Box with front membrane, key tappets, protection cover	51502280
70	Central module (controller)	LSCH-S1	1 current output	51502376
71	Central module (controller)	LSCH-S2	2 current outputs	51502377
72	Central module (controller)	LSCH-H1	1 current output + HART	51502378
73	Central module (controller)	LSCH-H2	2 current outputs + HART	51502379
74	Central module (controller)	LSCP-PA	PROFIBUS PA / no current output!	51502380
75	Central module (controller)	LSCP-DP	PROFIBUS DP / no current output!	51502381
80	Conductivity transmitter	MKIC	Conductivity + temperature input	51501206
90	Power supply unit (main module)	LTGA	100/115/230 V AC	51501585
91	Power supply unit (main module)	LTGD	24 V AC + DC	51501586
100	Terminal strip kit		Terminal strips 5/8/13 poles	51501587
101	Terminal strip kit PA/DP		Terminal strips 5/8/13 poles	51502281
110	Ribbon cable		20-wire line with connector	51501588
120	Cable entry kit Pg		Cable glands, plugs, Goretex filter	51501589
121	Cable entry kit M20		Cable glands, plugs, Goretex filter	51502282

Item	Kit designation	Name	Function/content	Order number
122	Cable entry kit Conduit		Cable glands, plugs, Goretex filter	51502283
130	Screw and gasket kit		All screws and gaskets	51501596
140	Protection cover kit		Protection cover for connection compartment	51502382

9.6 Return

If the transmitter has to be repaired, please return it *cleaned* to the sales centre responsible. Please use the original packaging, if possible.

Please enclose the completed "Declaration of contamination" (copy the second last page of these Operating Instructions) with the packaging and the transportation documents.
No repair without completed "Declaration of contamination"!

9.7 Disposal

The device contains electronic components and must therefore be disposed of in accordance with regulations on the disposal of electronic waste.
Please observe local regulations.

10 Technical Data

10.1 Input

Measured variables	Conductivity Concentration Temperature	
Measuring range	Conductivity:	recommended range: 100 $\mu\text{S}/\text{cm}$... 2000 mS/cm (uncompensated)
	Concentration – NaOH: – HNO ₃ : – H ₂ SO ₄ : – H ₃ PO ₄ :	0 ... 15 % 0 ... 25 % 0 ... 30 % 0 ... 15 %
	Temperature:	–35 ... +250 °C / –31 ... +482 °F
Cable specification	max. cable length 55 m / 180.46 ft with CLK5 cable (separate version)	
Binary inputs 1 and 2	Voltage:	10 ... 50 V DC
	Current consumption:	max. 10 mA at 50 V

10.2 Output

Output signal	Conductivity, concentration: Temperature (optional second current output)	0 / 4 ... 20 mA, galvanically isolated
Minimum distance for 0 / 4 ... 20 mA output signal	Conductivity measurement: – Measured value 0 ... 19.99 $\mu\text{S}/\text{cm}$: – Measured value 20 ... 199.9 $\mu\text{S}/\text{cm}$: – Measured value 200 ... 1999 $\mu\text{S}/\text{cm}$: – Measured value 0 ... 19.99 mS/cm : – Measured value 20 ... 200 mS/cm : – Measured value 200 ... 2000 mS/cm :	2 $\mu\text{S}/\text{cm}$ 20 $\mu\text{S}/\text{cm}$ 200 $\mu\text{S}/\text{cm}$ 2 mS/cm 20 mS/cm 200 mS/cm
	Concentration measurement:	no minimum distance
Signal on alarm	2.4 mA or 22 mA error current	
Load	max. 500 Ω	
Output range	Conductivity:	adjustable
	Temperature:	adjustable
Signal resolution	max. 700 digits/mA	
Separation voltage	max. 350 V_{RMS} / 500 V DC	
Overvoltage protection	acc. to EN 61000-4-5:1995	
Auxiliary voltage output	Output voltage:	15 V \pm 0.6 V
	Output current:	max. 10 mA
Contact outputs	Switching current with ohmic load ($\cos \varphi = 1$):	max. 2 A
	Switching current with inductive load ($\cos \varphi = 0.4$):	max. 2 A
	Switching voltage:	max. 250 V AC, 30 V DC
	Switching power with ohmic load ($\cos \varphi = 1$):	max. 500 VA AC, 60 W DC
	Switching power with inductive load ($\cos \varphi = 0.4$):	max. 500 VA AC
Limit contactor	Pickup / dropout delay:	0 ... 2000 s
Alarm	Function (switchable):	steady / fleeting contact
	Alarm delay:	0 ... 2000 s (min)

10.3 Power supply

Supply voltage	Depending on ordered version: 100 / 115 / 230 V AC +10 / -15 %, 48 ... 62 Hz 24 V AC/DC +20 / -15 %
Power consumption	max. 7.5 VA
Mains fuse	Fine-wire fuse, medium time lag, 250 V / 3.15 A

10.4 Performance characteristics

Measured value resolution	Temperature:	0.1 °C / 0.18 °F
Measured value deviation¹	Conductivity: – Display: – Conductivity signal output:	max. 0.5 % of measured value ± 4 digits max. 0.75 % of current output range
	Temperature – Display: – Temperature signal output:	max. 0.6 % of measuring range max. 0.75 % of current output range
Repeatability¹	Conductivity:	max. 0.2% of measured value ± 2 digits
Cell constant	5.9 cm ⁻¹	
Measuring frequency (oscillator)	2 kHz	
Temperature compensation	Range:	-10 ... +150 °C / 14 ... 302 °F
	Compensation types:	– none – linear with freely selectable temperature coefficient α – one freely programmable coefficient table (four tables available in versions with remote parameter set switching) – NaCl acc. to IEC 746-3
	Minimum distance for table:	1 K
Reference temperature	25 °C / 77 °F	
Temperature offset	adjustable, ± 5 °C / 9 °F, for temperature display adjustment	

1) acc. to IEC 746 part 1, nominal operating conditions

10.5 Environment

Ambient temperature	0 ... +55 °C / 32 ... 131 °F	
Ambient temperature limits	-10 ... +70 °C / 14 ... 158 °F (separate version) -10 ... +55 °C / 14 ... 131 °F (compact version) (see Fig. 41 "Permissible temperature ranges of Smartec S CLD132")	
Storage temperature	-25 ... +70 °C / -13 ... 158 °F	
Electromagnetic compatibility	Interference emission and interference resistance acc. to EN 61326: 1997 / A1: 1998	
Ingress protection	IP 67	
Relative humidity	10 ... 95%, non-condensing	
Vibration resistance acc. to IEC 60770-1 and IEC 61298-3	Oscillation frequency:	10 ... 500 Hz
	Deflection (peak value):	0.15 mm / 0.01"
	Acceleration (peak value):	19.6 m/s ²
Impact resistance	Display window:	9 J

10.6 Mechanical construction

Design, dimensions	Separate transmitter with mounting plate:	L x W x D: 225 x 142 x 109 mm / 8.86 x 5.59 x 4.29"
	Compact transmitter MV1, CS1, GE1, SMS versions:	L x W x D: 225 x 142 x 242 mm / 8.86 x 5.59 x 9.53"
	Compact transmitter VA1, AP1 versions:	L x W x D: 225 x 142 x 180 mm / 8.86 x 5.59 x 7.09"
Weight	Separate version:	approx. 2.5 kg / 5.5 lb.
	Compact version with CLS 52 sensor:	approx. 3 kg / 6.6 lb.
Transmitter materials	Housing:	stainless steel 1.4301, polished
	Front window:	polycarbonate

10.7 Measurement data of CLS52 sensor

Conductivity measuring range	recommended range: 100 µS/cm ... 2000 mS/cm (uncompensated)	
Measured value deviation	-5 ... 100 °C / 23 ... 212 °F	±10 µS/cm + 0.5 % of measured value
	> 100 °C / 212 °F	±30 µS/cm + 0.5 % of measured value
Cell constant	k = 5.9 cm ⁻¹	
Temperature sensor	Pt 100 (class A acc. to IEC 60751)	
Temperature measuring range	-5 ... +140 °C / -31 ... +284 °F	
Temperature response time	t ₉₀ < 5 s	versions with stainless steel socket (CLD132-*****1/2)
	t ₉₀ < 3.5 min	versions with encapsulated Pt 100 (CLD132-*****6/7)
Materials in contact with medium	Sensor	PEEK-GF20
	Varivent flange, APF flange: - Flange: - Seal:	stainless steel 1.4435 (AISI 316L) EPDM
	Metal temperature sensor socket: - Socket: - Seal:	stainless steel 1.4435 (AISI 316L) Chemraz®

10.8 Process

Process temperature	CLS52 sensor with separate version:	max. 125 °C / 257 °F at 70 °C / 158 °F ambient temperature
	Compact version:	max. 55 °C / 131 °F at 55 °C / 131 °F ambient temperature
Sterilisation	CLS52 sensor with separate version:	140 °C / 284 °F at 70 °C / 158 °F ambient temperature, 4 bar / 58 psi, max. 30 min
	Compact version:	140 °C / 284 °F at 35 °C / 95 °F ambient temperature, 4 bar / 58 psi, max. 30 min
Process pressure	max. 16 bar (90 °C) / 232 psi (194 °F) no underpressure allowed with versions with stainless steel socket (CLD132*****1, CLD132*****2)	
Ingress protection CLS52 sensor	IP 67 / NEMA 6	

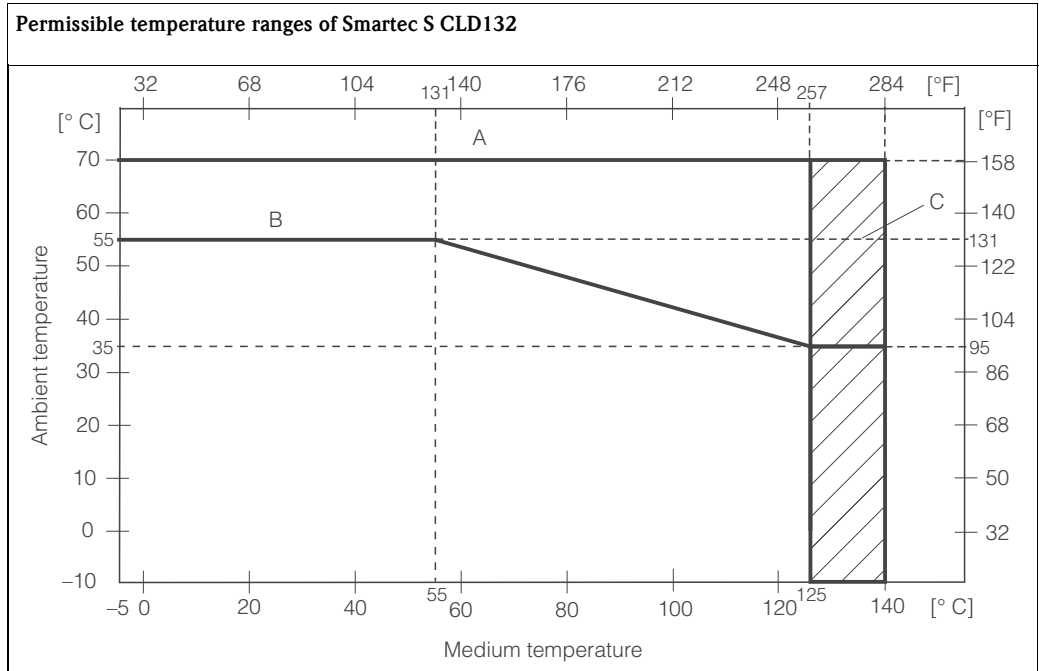

C07-CLD132xx-05-06-00-en-013.eps

Fig. 41: Permissible temperature ranges of Smartec S CLD132

- A CLS52 sensor with separate version
- B Compact version
- C short-term for sterilisation (< 30 min)

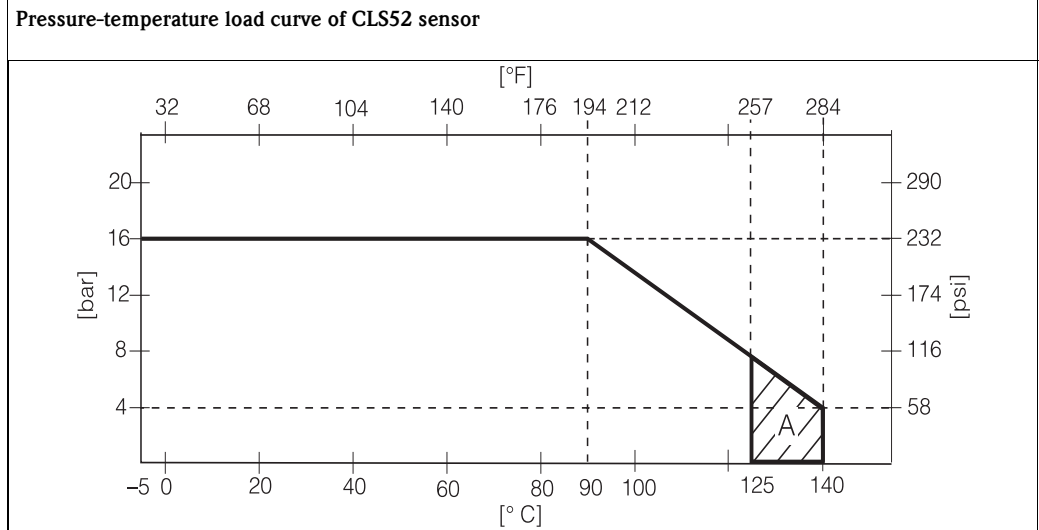

C07-CLS52xxx-05-05-00-en-001.eps

Fig. 42: Permissible pressure and temperature ranges of CLS52 sensor

- A short-term for sterilisation (< 30 min)

10.9 Chemical durability of CLS52 sensor

Medium	Concentration	PEEK	1.4435 (AISI 316L)	Chemraz	EPDM
Caustic soda NaOH	0 ... 10 %	20 ... 100 °C / 68 ... 212 °F	20 ... 90 °C / 68 ... 194 °F	20 ... 100 °C / 68 ... 212 °F	20 ... 100 °C / 68 ... 212 °F
	0 ... 50 %	20 ... 100 °C / 68 ... 212 °F	20 ... 90 °C / 68 ... 194 °F	20 ... 100 °C / 68 ... 212 °F	20 ... 60 °C / 68 ... 140 °F
Nitric acid HNO ₃	0 ... 10 %	20 ... 100 °C / 68 ... 212 °F	20 ... 100 °C / 68 ... 212 °F	20 ... 100 °C / 68 ... 212 °F ¹	20 °C / 68 °F
	0 ... 25 %	20 ... 40 °C / 68 ... 104 °F	20 ... 100 °C / 68 ... 212 °F	20 ... 100 °C / 68 ... 212 °F ¹	not suitable
Phosphoric acid H ₃ PO ₄	0 ... 10 %	20 ... 100 °C / 68 ... 212 °F	20 ... 100 °C / 68 ... 212 °F	20 ... 100 °C / 68 ... 212 °F	20 ... 80 °C / 68 ... 176 °F
	0 ... 30 %	20 ... 100 °C / 68 ... 212 °F	20 ... 85 °C / 68 ... 185 °F	20 ... 100 °C / 68 ... 212 °F	20 ... 80 °C / 68 ... 176 °F
Sulphuric acid H ₂ SO ₄	0 ... 2.5 %	20 ... 100 °C / 68 ... 212 °F ¹	20 ... 70 °C / 68 ... 158 °F	20 ... 100 °C / 68 ... 212 °F	20 ... 30 °C / 68 ... 86 °F
	0 ... 30 %	20 ... 100 °C / 68 ... 212 °F ¹	not suitable	20 ... 100 °C / 68 ... 212 °F	20 ... 30 °C / 68 ... 86 °F

1) slight affect possible

No responsibility is taken for the correctness of this information.

10.10 Documentation

Indumax H CLS52, Technical Information TI 167C/07/en	Order no.: 50086110
PROFIBUS PA/DP, Field communication with Smartec S CLD132, Operating Instructions BA 213C/07/en	Order no.: 51502194
HART®, Field communication with Smartec S CLD132, Operating Instructions BA 212C/07/en	Order no.: 51502192

11 Appendix

Operating matrix

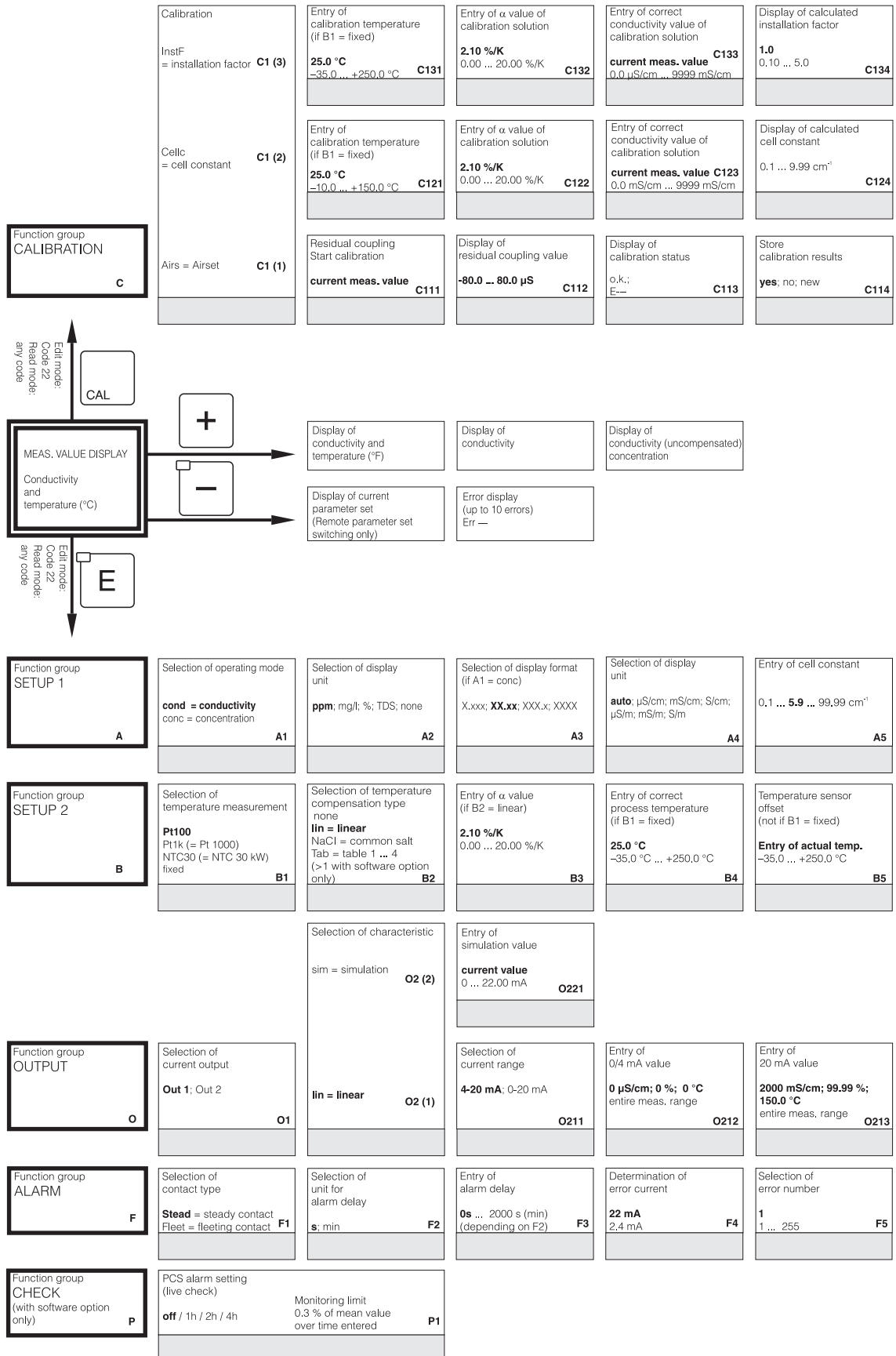

Display of calibration status o.k.; E-- C135	Store calibration results yes; no; new C136
---	---

Display of calibration status o.k.; E-- C125	Store calibration results yes; no; new C126
---	---

Entry of installation factor 01 ... 1.00 ... 5.00 A6	Entry of measured value damping 1 (no damping) 1 ... 60 A7
--	--

Display of temperature difference (not if B1 = fixed) 0.0 °C -5.0 ... 5.0 °C B6	Field for entry of user setting
---	---------------------------------

Set alarm contact to be effective yes; no F6	Set error current to be effective no; yes F7	Select 'next error' or return to menu next = next error ←R F8
--	--	---

Function group RELAY (with software option only) R	Selection of function Alarm: Limit; Alarm+limit R1	Selection of contact switch-on point 2000 mS/cm; 99.99 % entire meas. range R2	Selection of contact switch-off point 2000 mS/cm; 99.99 % entire meas. range R3	Pickup delay setting 0 s 0 ... 2000 s R4	Dropout delay setting 0 s 0 ... 2000 s R5
Function group ALPHA TABLE T	Selection of tables 1 1 ... 4 (>1 with software option only) T1	Selection of table option read edit T2	Entry of number of value pairs in table 1 1 ... 10 T3	Selection of table value pair 1 1 ... number of T3 assign T4	Entry of temperature value (x value) 0,0 °C -35,0 ... 250,0 °C T5
Function group CONCENTRATION K	Selection of active concentration table NaOH; H₂SO₄; H₃PO₄; HNO₃ User 1 ... 4 K1	Multiplication factor for concentration value of a user table (with user tables only) 1 0.5 ... 1.5 K2	Selection of tables 1 1 ... 4 (>1 with software option only) K3	Selection of table option read edit K4	Entry of number of value pairs in table 4 1 ... 16 K5
Function group SERVICE S	Selection of language ENG; GER ITA; FRA ESP; NEL S1	Selection of HOLD effect froz = last value fixed = fixed value S2	Entry of fixed value (only if S2 = fixed) 0 0 ... 100 % of 20 or 16 mA S3	HOLD configuration none = no HOLD S+C = during setup and calibration Setup = during setup CAL = dur. calibration S4	Manual HOLD off on S5
Function group E+H SERVICE E	Module selection Sens = sensor E1(4)	Software version SW version E141	Hardware version HW version E142	Display of serial number E143	Entry of serial number yes no E144
	MainB = Mainboard E1(3)	Software version SW version E131	Hardware version HW version E132	Display of serial number E133	
	Trans = Transmitter E1(2)	Software version SW version E121	Hardware version HW version E122	Display of serial number E123	
	Contr = Controller E1(1)	Software version SW version E111	Hardware version HW version E112	Display of serial number E113	
Function group INTERFACE I	Entry of address HART: 0 ... 15 PROFIBUS: 1 ... 126 I1	Tag description @@@@@@@@ I2			
Function group DETERMIN. OF TEMPERATURE COEFFICIENT (with software option only) D	Entry of compensated conductivity current value 0 ... 9999 D1	Display of uncompensated conductivity current value 0 ... 9999 D2	Entry of current temperature current value -35 ... +250 °C D3	Display of determined Alpha value 2.10 %/K D4	
Function group REMOTE PARAMETER SET SWITCHING (MRS) M	Selection of binary inputs for MRS 2 0 ... 2 M1	Display of current parameter set 1 1 ... 4 if M1=0 M2	Selection of parameter set 1 1 ... 4 if M1=0 1 ... 2 if M1=1 M3	Selection of oper. mode cond = conductivity conc = concentration M4	Selection of medium NaOH; H₂SO₄; H₃PO₄; HNO₃ User 1 ... 4 (if M4=conc) M5

Selection of simulation (only if R1 = limit) auto manual R6	Switch simulation on or off (only if R6 = manual) off on R7
---	--

Entry of temperature coefficient α (y value) 2.10 %/K 0.00 ... 20.00 %/K T6	Output table status o,k. yes; no T7
--	--

Selection of table value pair 1 1 ... number from K5 K6	Entry of uncompensated conductivity value 0.0 $\mu\text{S/cm}$ 0.0 ... 9999 mS/cm K7	Entry of associated concentration value 0.00 % 0 ... 99.99 % K8	Entry of associated temperature value 0.0 $^{\circ}\text{C}$ -35.0 ... +250.0 $^{\circ}\text{C}$ K9	Output table status o,k. yes; no K10
--	--	--	---	---

Entry of HOLD dwell period 10 0 ... 999 s S6	Entry of release code for SW upgrade MRS 0000 0000 ... 9999 S7	Display of order number S8	Display of serial number S9	Instrument reset no; Sens = sensor data; Facyt = factory settings S10	Start instrument test no; Display S11
---	---	---	--	---	--

Entry of serial number 1st digit 0 0 ... 9 E145	Entry of serial number 2nd digit 1 1 ... 9, A, B, C E146	Entry of serial number 3rd - 6th digit 1 1 ... FFF E147	Confirm serial number yes no E148
--	---	--	--

Selection of temperature compensation none; lin ; NaCl; Tab 1 ... 4 if M4=cond M6	Entry of alpha value 2.1 0 ... 20 %/K if M6=lin M7	Entry of measured value for 0/4 mA value cond.: 0 ... 2000 mS/cm conc.: 0 ... 99.99 % Unit: A2 Format: A3 M8	Entry of measured value for 20 mA value cond.: 0 ... 2000 mS/cm conc.: 0 ... 99.99 % Unit: A2 Format: A3 M9	Entry of limit switch-on point cond.: 0 ... 2000 mS/cm conc.: 0 ... 99.99 % Unit: A2 Format: A3 M10	Entry of limit switch-off point cond.: 0 ... 2000 mS/cm conc.: 0 ... 99.99 % Unit: A2 Format: A3 M11
---	--	--	---	---	--

Index

A

Access codes	26
Accessories	59
Airset	10
Alarm	37
Alarm contact	29

C

Cable	59
Calibration	51
Calibration solutions	60
Check	
Conductivity sensors	56
Electrical connection	22
Function	28
Installation	17
Instrument	57
Line extension and junction box	58
Cleaning	56
CLS52 sensor data	73
Commissioning	5, 28–29, 53
Communication interfaces	47, 53
Concentration measurement	42
Configuration	33
Connection compartment sticker	21
Connection diagram	20
Connection variants	14

D

Declaration of conformity	8
Dismantling	54
Display	23
Disposal	70

E

E+H Service	46
Electrical connection	18
Binary inputs	20
Electrical icons	6
Environment	72
Errors	
Instrument specific	65
Process specific	62
System error messages	61
Exploded view	68
Extension cable	59

F

Factory settings	29
------------------------	----

H

Hold function	27
Hold-Funktion	45

I

Icons	
Electrical	6

Immunity to interference	5
Incoming acceptance	10
Input	71
Installation	5, 9–10, 15, 17
Compact version	16
Separate version	15
Installation conditions	10
Compact version	13
Separate version	11
Installation instructions	15
Instrument-specific errors	65
Interfaces	47

J

Junction box	59
--------------------	----

K

Key assignment	24
----------------------	----

L

Local operation	26
-----------------------	----

M

Maintenance	54
Measuring system	56
Smartec S CLD132	54
Measuring system	9
Mechanical construction	73
Menu structure	27
Monitoring functions	
Check	38
MRS	48

N

Nameplate	7
-----------------	---

O

Operating elements	24
Operating matrix	76
Operating modes	26
Operation	5, 23–24, 26
Operational safety	5
Optoscope	58, 60
Order	7
Output	71
Outputs	36

P

Parameter sets	48
PCS alarm	38
Performance characteristics	72
Post mounting	15
Post mounting kit	60
Post-connection check	22
Power supply	72
Process	73
Process-specific errors	62

Product structure	7
Q	
Quick setup	30
R	
Relay configuration	39
Remote measuring range switching	48
Remote parameter set switching	48
Replacement of central module	55
Return	6, 70
S	
Scope of delivery	8
Sensors	59
Service	45
Setup 1	33
Setup 2	34
Software upgrade	60
Spare parts	67
Kits	69
Start-up	28
Storage	10
Supplementary documentation	75
Symbols	
Electrical	6
Safety	6
System error messages	61
T	
Technical data	71–73, 75
Temperature coefficient	48
Temperature compensation	41
linear	34
NaCl	34
with table	34
Transport	10
Troubleshooting	61
U	
Use	
designated	5
W	
Wall distance	10
Wall mounting	15
Wiring diagram	19









Declaration of contamination

Dear customer,

Because of legal determinations and for the safety of our employees and operating equipment, we need this "Declaration of contamination" with your signature before your order can be handled. Please, include the completely filled in declaration with the device and the shipping documents in any case. Add also safety sheets and / or specific handling instructions if necessary.

Type of device / sensor:	_____	Serial no.:	_____
Medium / concentration:	_____	Temperature:	_____ Pressure: _____
Cleaned with:	_____	Conductivity:	_____ Viscosity: _____

Warning hints for medium used (mark the appropriate hints)

							
<input type="checkbox"/>	<input type="checkbox"/>	<input type="checkbox"/>	<input type="checkbox"/>	<input type="checkbox"/>	<input type="checkbox"/>	<input type="checkbox"/>	<input type="checkbox"/>
radioactive	explosive	caustic	poisonous	harmful to health	biologically hazardous	inflammable	safe

Reason for return

Company data

Company:	_____	Contact person:	_____
	_____		_____
Address:	_____	Department:	_____
	_____	Phone:	_____
	_____	Fax / e-mail:	_____
		Your order no.:	_____

I hereby certify that the returned equipment has been cleaned and decontaminated acc. to good industrial practices and is in compliance with all regulations. This equipment poses no health or safety risks due to contamination.

(Place, date)

(Company stamp and legally binding signature)

www.endress.com/worldwide

Endress+Hauser 
People for Process Automation

