

BMXART0814

analog input module M340 - 8 inputs -
temperature



Main

Range of product	Modicon M340 automation platform
Product or component type	Analog input module
Electrical connection	2 connectors 40 ways
Input output isolation	Isolated
Input level	Low level
Analogue input number	8
Analogue input type	Thermocouple -50...+1769 °C thermocouple S Thermocouple -50...+1769 °C thermocouple R Thermocouple -270...+400 °C thermocouple T Thermocouple -270...+1370 °C thermocouple K Thermocouple -270...+1000 °C thermocouple E Thermocouple -200...+900 °C thermocouple L Thermocouple -200...+760 °C thermocouple J Thermocouple -200...+600 °C thermocouple U Thermocouple +270...+1300 °C thermocouple N Thermocouple +130...+1820 °C thermocouple B Temperature probe -60...+180 °C Ni 1000 Temperature probe -60...+180 °C Ni 100 Temperature probe -200...+850 °C Pt 100 IEC Temperature probe -200...+850 °C Pt 100 IEC Temperature probe -100...+450 °C Pt 1000 UL/JIS Temperature probe -100...+450 °C Pt 100 UL/JIS Temperature probe -100...+260 °C Cu 10 Resistor 4000 Ohm 4 wires Resistor 4000 Ohm 3 wires Resistor 4000 Ohm 2 wires Resistor 400 Ohm 4 wires Resistor 400 Ohm 3 wires Resistor 400 Ohm 2 wires Voltage +/- 80 mV Voltage +/- 640 mV Voltage +/- 40 mV Voltage +/- 320 mV Voltage +/- 160 mV Voltage +/- 1.28 V

Complementary

Analog/Digital conversion	Sigma delta 16 bits
Analogue input resolution	15 bits + sign
Input impedance	10 MOhm
Permitted overload on inputs	+/- 7.5 V +/- 80 mV +/- 7.5 V +/- 640 mV +/- 7.5 V +/- 40 mV +/- 7.5 V +/- 320 mV +/- 7.5 V +/- 160 mV +/- 7.5 V +/- 1.28 V
Common mode rejection	120 dB 50/60 Hz
Differential mode rejection	60 dB 50/60 Hz
Cold junction compensation	External by Pt100 probe
Type of filter	First order digital filtering
Nominal read cycle time	200 ms with thermocouple 400 ms with temperature probe

The information provided in this documentation contains general descriptions and/or technical characteristics of the performance of the products contained herein. This documentation is not intended as a substitute for and is not to be used for determining suitability or reliability of these products for specific user applications. It is the duty of any such user or integrator to perform the appropriate and complete risk analysis, evaluation and testing of the products with respect to the relevant specific application or use thereof. Neither Schneider Electric Industries SAS nor any of its affiliates or subsidiaries shall be responsible or liable for misuse of the information contained herein.

Measurement error	1.3 °C Ni 1000 0...60 °C 0.12 % of full scale 4000 Ohm 25 °C 0.12 % of full scale 400 Ohm 25 °C 0.05 % of full scale +/- 80 mV 25 °C 0.05 % of full scale +/- 640 mV 25 °C 0.05 % of full scale +/- 40 mV 25 °C 0.05 % of full scale +/- 320 mV 25 °C 0.05 % of full scale +/- 160 mV 25 °C 0.05 % of full scale +/- 1.28 V 25 °C <= 0.3 % of full scale 400 Ohm 0...60 °C <= 0.2 % of full scale 4000 Ohm 0...60 °C <= 0.2 % of full scale +/- 40 mV 0...60 °C <= 0.15 % of full scale +/- 80 mV 0...60 °C <= 0.15 % of full scale +/- 640 mV 0...60 °C <= 0.15 % of full scale +/- 320 mV 0...60 °C <= 0.15 % of full scale +/- 160 mV 0...60 °C <= 0.15 % of full scale +/- 1.28 V 0...60 °C +/- 5 °C thermocouple T 0...60 °C +/- 5 °C thermocouple N 0...60 °C +/- 5 °C thermocouple K 0...60 °C +/- 5 °C thermocouple E 0...60 °C +/- 5 °C thermocouple B 0...60 °C +/- 4.5 °C thermocouple U 0...60 °C +/- 4.5 °C thermocouple S 0...60 °C +/- 4.5 °C thermocouple R 0...60 °C +/- 4.5 °C thermocouple L 0...60 °C +/- 4.5 °C thermocouple J 0...60 °C +/- 4 °C Cu 10 25 °C +/- 4 °C Cu 10 0...60 °C +/- 3.7 °C thermocouple T 25 °C +/- 3.7 °C thermocouple N 25 °C +/- 3.7 °C thermocouple K 25 °C +/- 3.7 °C thermocouple E 25 °C +/- 3.5 °C thermocouple B 25 °C +/- 3.2 °C thermocouple S 25 °C +/- 3.2 °C thermocouple R 25 °C +/- 3 °C thermocouple L 25 °C +/- 3 °C Ni 100 0...60 °C +/- 2.8 °C thermocouple J 25 °C +/- 2.7 °C thermocouple U 25 °C +/- 2.1 °C Pt 1000 25 °C +/- 2.1 °C Pt 100 25 °C +/- 2.1 °C Ni 100 25 °C +/- 2 °C Pt 1000 0...60 °C +/- 2 °C Pt 100 0...60 °C +/- 0.7 °C Ni 1000 25 °C
Temperature drift	30 ppm/°C Pt 1000 30 ppm/°C Pt 100 30 ppm/°C Ni 100 30 ppm/°C Cu 10 30 ppm/°C +/- 80 mV 30 ppm/°C +/- 640 mV 30 ppm/°C +/- 40 mV 30 ppm/°C +/- 320 mV 30 ppm/°C +/- 160 mV 30 ppm/°C +/- 1.28 V 25 ppm/°C thermocouple U 25 ppm/°C thermocouple T 25 ppm/°C thermocouple S 25 ppm/°C thermocouple R 25 ppm/°C thermocouple N 25 ppm/°C thermocouple L 25 ppm/°C thermocouple K 25 ppm/°C thermocouple J 25 ppm/°C thermocouple E 25 ppm/°C thermocouple B 25 ppm/°C Ni 1000 25 ppm/°C 4000 Ohm 25 ppm/°C 400 Ohm
Recalibration	Internal

Detection type	Open circuit thermocouple U Open circuit thermocouple T Open circuit thermocouple S Open circuit thermocouple R Open circuit thermocouple N Open circuit thermocouple L Open circuit thermocouple K Open circuit thermocouple J Open circuit thermocouple E Open circuit thermocouple B Open circuit Pt 1000 Open circuit Pt 100 Open circuit Ni 1000 Open circuit Ni 100 Open circuit Cu 10
Maximum wiring resistance	500 Ohm 4 wires Pt 1000 500 Ohm 4 wires Ni 1000 50 Ohm 4 wires Pt 100 50 Ohm 4 wires Ni 100 50 Ohm 4 wires Cu 10 200 Ohm 3 wires Pt 1000 200 Ohm 3 wires Ni 1000 200 Ohm 2 wires Pt 1000 200 Ohm 2 wires Ni 1000 20 Ohm 3 wires Pt 100 20 Ohm 3 wires Ni 100 20 Ohm 3 wires Cu 10 20 Ohm 2 wires Pt 100 20 Ohm 2 wires Ni 100 20 Ohm 2 wires Cu 10
Measurement resolution	80/2exp14 mV +/- 80 mV 640/2exp14 mV +/- 640 mV 4000/2exp14 mV 4000 Ohm 40/2exp14 mV 400 Ohm 40/2exp14 mV +/- 40 mV 320/2exp14 mV +/- 320 mV 160/2exp14 mV +/- 160 mV 1280/2exp14 mV +/- 1.28 V 0.1 °C thermocouple U 0.1 °C thermocouple T 0.1 °C thermocouple S 0.1 °C thermocouple R 0.1 °C thermocouple N 0.1 °C thermocouple L 0.1 °C thermocouple K 0.1 °C thermocouple J 0.1 °C thermocouple E 0.1 °C thermocouple B 0.1 °C Pt 1000 0.1 °C Pt 100 0.1 °C Ni 1000 0.1 °C Ni 100 0.1 °C Cu 10
Maximum conversion value	+/- 102.5 % +/- 80 mV +/- 102.5 % +/- 640 mV +/- 102.5 % +/- 40 mV +/- 102.5 % +/- 320 mV +/- 102.5 % +/- 160 mV +/- 102.5 % +/- 1.28 V +/- 100 % 4000 Ohm +/- 100 % 400 Ohm
Status LED	1 LED red I/O 1 LED red ERR 1 LED per channel green channel diagnostic 1 LED green RUN
Product weight	0.165 kg
Current consumption	150 mA at 3.3 V DC

Environment

Ambient air temperature for operation	0...60 °C
Relative humidity	10...95 % without condensation
IP degree of protection	IP20
Protective treatment	TC
Environmental characteristic	3C4 conforming to EN/IEC 60721-3-3 3C3 conforming to EN/IEC 60721-3-3

Modules Mounted on Racks

Dimensions

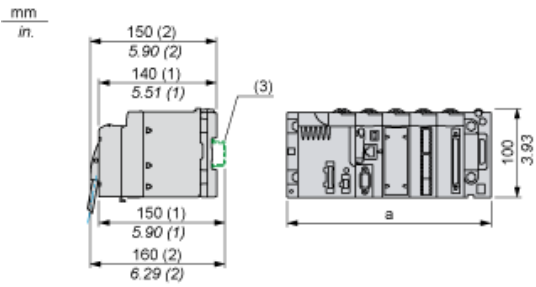

- (1) With removable terminal block (cage, screw or spring).
- (2) With FCN connector.
- (3) On AM1 ED rail: 35 mm wide, 15 mm deep. Only possible with BMXXBP0400/0400H/0600/0600H/0800/0800H rack.

Rack references	a in mm	a in in.
BMXXBP0400 and BMXXBP0400H	242.4	09.54
BMXXBP0600 and BMXXBP0600H	307.6	12.11
BMXXBP0800 and BMXXBP0800H	372.8	14.68
BMXXBP1200 and BMXXBP1200H	503.2	19.81

Wiring Diagram

Below example shows a probe configuration with:

- Channel 0/4: Thermocouple
- Channel 1/5: 2-wires RTD
- Channel 2/6: 3-wires RTD
- Channel 3/7: 4-wires RTD

Module Front view - cabling view

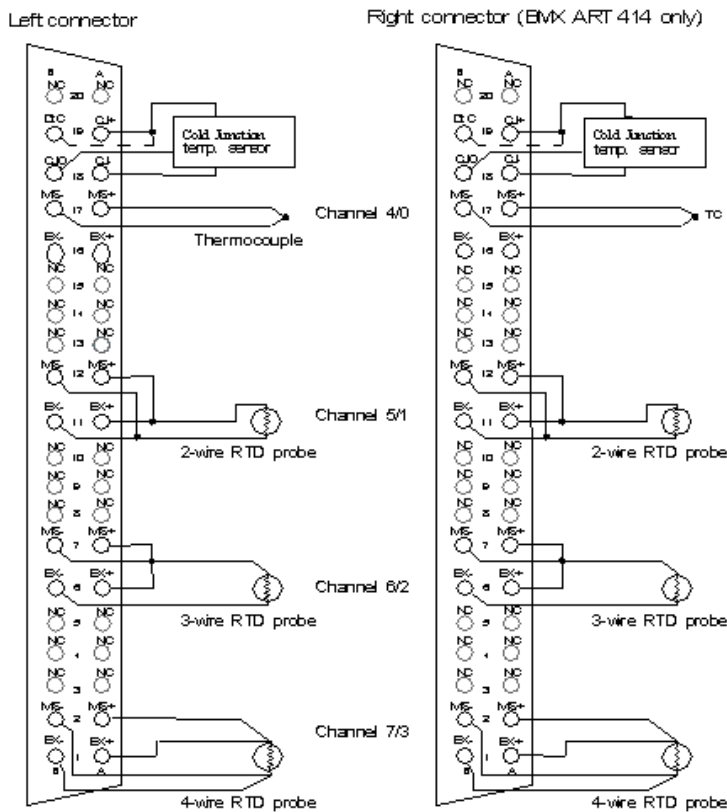

MS+ Thermocouple + input

MS- Thermocouple - input

EX+ RTD probe current generator + output

EX- RTD probe current generator - output

NC Not connected

DiC The CJC sensor detection input is connected to CJ+ if the sensor type is DS600. It is not connected (NC) if the sensor type is LM31.

NOTE: The CJC sensor is needed for TC only.